

COLLISION INFORMATION

TABLE OF CONTENTS

	page		page
COLLISION INFORMATION		STANDARD PROCEDURE	
WARNING		SERVICE AFTER A SUPPLEMENTAL	
SAFETY NOTICE	2	RESTRAINT DEPLOYMENT	39
USE OF HEAT DURING REPAIR	2	BASECOAT/CLEARCOAT FINISH	42
SPECIFICATIONS		FINESSE SANDING, BUFFING, AND	
VEHICLE IDENTIFICATION NUMBER.	3	POLISHING	42
STANDARDIZED STEEL IDENTIFICATION.	5	PAINT TOUCH-UP.	42
WELD PROCESS	14	BED LINER REPAIR	43
BODY OPENING DIMENSIONS	15	NON-STRUCTURAL SHEET METAL	
FRAME DIMENSIONS	22	REPAIR	45
GAP AND FLUSH DIMENSIONS.	27	WELDING AND WELD BONDING	51
PAINT CODES	38	BODY SIDE REPAIR	62
VEHICLE CERTIFICATION LABEL	39	LIGHT DUTY FRONT FRAME RAIL TIP	
		REPLACEMENT	67
		HYDROFORM FENDER RAIL REPAIR	71
		CORROSION PROTECTION.	74
		MATERIAL LOCATIONS	
		SEALERS AND SOUND DEADENERS	75
		SOUND DEADENER LOCATIONS.	76
		SEALER LOCATIONS.	86
		STRUCTURAL ADHESIVE LOCATIONS	103

Collision Information

Warning

SAFETY NOTICE

CAUTION: All service and rebuilding instructions contained herein are applicable to, and for the convenience of, the automotive trade only. All test and repair procedures on components or assemblies in non-automotive applications should be repaired in accordance with instructions supplied by the manufacturer of the total product.

Proper service and repair is important to the safe, reliable operation of all motor vehicles. The service produces recommended and described in this publication were developed for professional service personnel, and are effective methods for performing vehicle repair. Following these procedures will help ensure efficient economical vehicle performance and service reliability. Some service procedures require the use of special tools designed for specific procedures. These special tools should be used as recommended throughout this publication.

Special attention should be exercised when working with spring-or tension-loaded fasteners and devices such as E-Clips, Circlips, Snap rings, etc., since careless removal may cause personal injury. Always wear safety goggles when working on vehicles or vehicle components.

It is important to note that this publication contains various Cautions and Warnings. These should be read carefully in order to minimize risk of personal injury or the possibility that improper service methods may damage the vehicle or render it unsafe. It is important to note that these Cautions and Warnings cover only the situations and procedures Chrysler Group LLC has encountered and recommended. Chrysler Group LLC cannot possibly know, evaluate, and advise the service trade of all conceivable ways in which service may be performed, or of the possible hazards of each. Consequently, Chrysler Group LLC has not undertaken any such broad service review. Accordingly, anyone uses a service procedure or tool that is not recommended in this publication must be certain that neither personal safety, nor vehicle safety, will be jeopardized by the service methods they select.

USE OF HEAT DURING REPAIR

WARNING: Chrysler Group LLC engineering's position on the use of heat during collision repair is as follows:

- Any body panel or frame component damaged which is to be repaired and reused, must be repaired using the "cold straightening" method. No heat may be used during the straightening process.
- During rough straightening prior to panel replacement, damaged panels or frame components may be heated to assist in body/frame realignment. The application of heat must be constrained to the parts which will be replaced and not allowed to affect any other components.

This "no heat" recommendation is due to the extensive use of high strength and advanced high strength steels in Chrysler Group LLC products. High-strength materials can be substantially and negatively affected from heat input which will not be obviously known to the repairer or consumer.

Ignoring these recommendations may lead to serious compromises in the ability to protect occupants in a future collision event, reduce the engineered qualities and attributes, or decrease the durability and reliability of the vehicle.

This statement supersedes any previously released information by the Chrysler Group LLC.

Failure to follow these instructions may result in serious or fatal injury.

Specifications

VEHICLE IDENTIFICATION NUMBER

The Vehicle Identification Number (VIN) plate (1) is located on the lower windshield fence near the left a-pillar. The VIN contains 17 characters that provide data concerning the vehicle. Refer to the VIN decoding chart to determine the identification of a vehicle.

The VIN is also imprinted on the:

- Equipment Identification Plate.
- Vehicle Safety Certification Label.
- Frame rail.

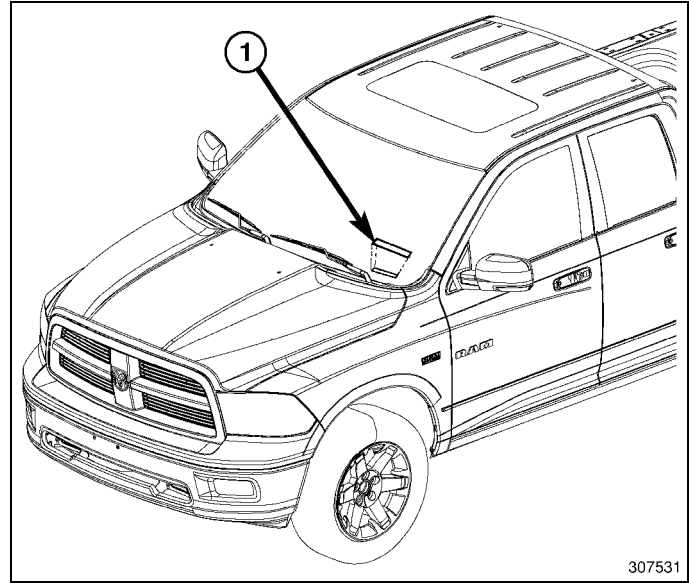

To protect the consumer from theft and possible fraud the manufacturer is required to include a Check Digit at the ninth position of the VIN. The check digit is used by the manufacturer and government agencies to verify the authenticity of the vehicle and official documentation. The formula to use the check digit is not released to the general public.

VEHICLE IDENTIFICATION NUMBER DECODING CHART

NOTE: All Seating Positions (ASP), Outboard Seating Positions (OSP)

POSITION	INTERPRETATION	CODE = DESCRIPTION
1, 2, 3	WMI (World Manufacturer Identifier)	1D7 = Chrysler Group LLC - Truck 3D7 = Chrysler De Mexico - Truck 3D6 = Chrysler De Mexico - Truck

VEHICLE IDENTIFICATION NUMBER DECODING CHART, continued

POSITION	INTERPRETATION	CODE = DESCRIPTION
4	Gross Vehicle Weight Rating	<p>*Active Belts (ASP) Front Air Bags (OSP) Without Side Inflatable Restraints</p> <p>C = 6001 - 7000 lbs (2722 - 3175 KG) D = 7001 - 8000 lbs (3176 - 3628 KG) E = 8001 - 9000 lbs (3629 - 4082 KG) F = 9001 - 10000 lbs (4083 - 4535 KG)</p> <p>*Active Belts (ASP) Front Air Bags (OSP) With Side Inflatable Restraints Front Row</p> <p>H = 6,001-7,000 lbs. (2722 - 3175 KG) J = 6001 - 7000 lbs (2722 - 3175 KG) K = 7001 - 8000 lbs (3176 - 3628 KG) L = 8001 - 9000 lbs (3629 - 4082 KG) M = 9001 -10000 lbs (4083 - 4535 KG)</p> <p>*Active Belts (ASP) Front Air Bags (OSP) With Side Inflatable Restraints All Rows</p> <p>R = 6001 - 7000 lbs (2722 - 3175 KG) S = 7001 - 8000 lbs (3176 - 3628 KG) T = 8001 - 9000 lbs (3629 - 4082 KG) U = 9001 - 10000 lbs (4083 - 4535 KG)</p> <p>*Active Belts (ASP) Trucks Over 10000# (4536 KG) GVWR</p> <p>3 = 10001 - 14000 lbs (4536 - 6350 KG)</p> <p>Incomplete Vehicles</p> <p>W = Incomplete Vehicles With Hydraulic Brakes</p>
5	Vehicle Line	<p>B = Ram Pickup Light Duty (4x2) (1500) V = Ram Pickup Light Duty (4x4) (1500) P = Ram Pickup Heavy Duty (4x2) (2500) T = Ram Pickup Heavy Duty (4x4) (2500) M = Ram Pickup Heavy Duty (4x2) (3500) Y = Ram Pickup Heavy Duty (4x4) (3500)</p>
6	Series	<p>1 = 1500 8 = 1500 HEV (Hybrid Electric Vehicle) 2 = 2500 3 = 3500 With Sales Code "AR9" = Single Rear Wheels 4 = 3500 With Sales Code "WLA" = Dual Rear Wheels</p>
7	Body Style	<p>C = Crew Cab E = Regular Cab G = Quad Cab H = Mega Cab</p>

VEHICLE IDENTIFICATION NUMBER DECODING CHART, continued

POSITION	INTERPRETATION	CODE = DESCRIPTION
8	Engine	K = 3.7L 6 CYL Gasoline Non – Turbo (EKG) P = 4.7L 8 CYL Gasoline Non – Turbo (EVE) T = 5.7L 8 CYL Gasoline Non – Turbo (EZC,EZE,EZH) L = 6.7L 6 CYL Diesel (ETJ)
9	Check Digit	0 through 9 or X
10	Model Year	A = 2010
11	Plant Location	S = Warren Truck Assembly G = Saltillo Assembly
12 – 17	Vehicle Build Sequence	A six digit number assigned by assembly plant.

STANDARDIZED STEEL IDENTIFICATION

In an effort to reduce confusion over the large number of steel grades in use, and the repairability and weldability concerns involved with each, Chrysler Group LLC has instituted new nomenclature which is applicable to material call-outs and BIW exploded views released for use in the repair industry.

All materials listed in the key may not be used on a given model, nor may every panel be identified in the blow-up (ex: some groups do not show fascias).

WARNING: Chrysler Group LLC engineering's position on the use of heat during collision repair is as follows:

- Any body panel or frame component damaged which is to be repaired and reused, must be repaired using the "cold straightening" method. No heat may be used during the straightening process.
- During rough straightening prior to panel replacement, damaged panels or frame components may be heated to assist in body/frame realignment. The application of heat must be constrained to the parts which will be replaced and not allowed to affect any other components.

This "no heat" recommendation is due to the extensive use of high strength and advanced high strength steels in Chrysler Group LLC products. High-strength materials can be substantially and negatively affected from heat input which will not be obviously known to the repairer or consumer.

Ignoring these recommendations may lead to serious compromises in the ability to protect occupants in a future collision event, reduce the engineered qualities and attributes, or decrease the durability and reliability of the vehicle.

This statement supersedes any previously released information by the Chrysler Group LLC.

Failure to follow these instructions may result in serious or fatal injury.

NOTE: Corrosion protection must be restored after repair.

- **LS** - Good repairability and weldability (least sensitive to heat). May be attached using the preferred Squeeze Type Resistance Spot Welding (STRSW) process, weld bonding where appropriate, or MIG welding. Materials have a tensile strength of less than 270 MPa.
- **HS** - Some repairability and good weldability (the higher the strength of the steel, the greater the sensitivity to heat). May be attached using STRSW, weld bonding, and MIG welding. Material tensile strength range between 270 MPa and 600 MPa and includes DP590.
- **VHS** - Very limited repairability and weldability (very sensitive to heat). Attach only at OE defined locations using OE defined procedures. Material tensile strengths are greater than 600 MPa. This category includes hot-stamped boron materials which are also termed "press hardened." Specialized cutters are required with many materials in this group.
- **LM** - Good repairability and weldability. May be attached using STRSW, weld bonding, and Flux Core Arc Welding (FCAW).
- **AL** - Stamped aluminum sheet metal panels may be repairable with specialized tools and techniques.
- **MG** - Magnesium - no repairability, replacement components only.
- **PL and PL-R** - Some repairability depending upon the type of plastic involved, the degree of damage, and the component function. Cosmetic components such as fascias (PL) have a higher degree of repair allowed than those components which can carry components and loads. Where PL-R components are bonded to steel structure, Chrysler Group LLC will identify the proper adhesive to attach the replacement panel. Repair materials for PL are commonly available in the collision repair market.
- **CO** - Composite materials may be fiber reinforced (ex: Kevlar) panels or co-molded assemblies of steel and plastic. Any of these require specialized repair materials and processes.

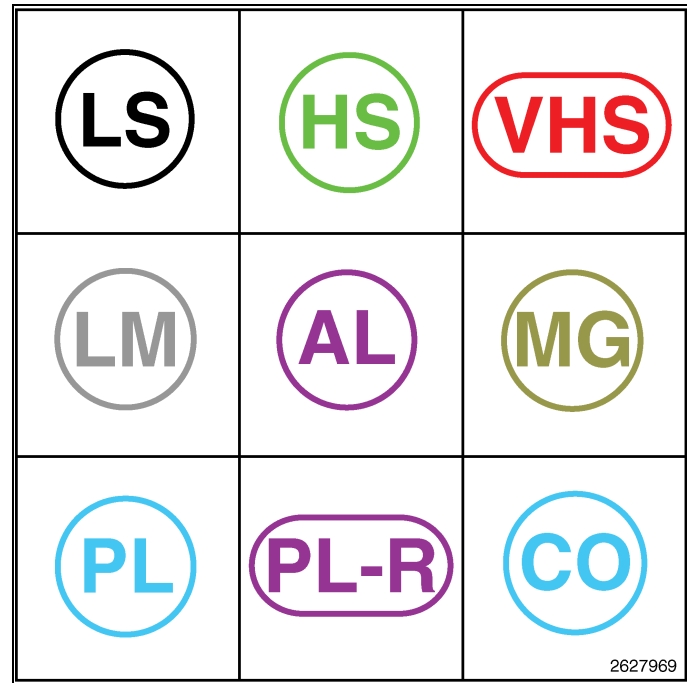

Additional information on sectioning of components will also be identified in publications such as the Chrysler Group LLC **Non-Structural Sheet Metal Repair Guide** (81-316-0610) and **Structural Sectioning Guide** (81-316-0859).

CALLOUT KEY	DESCRIPTION	COLOR
LS	Low-Strength Steel	Black
HS	High-Strength Steel	Green
VHS	Very High-Strength Steel	Red
LM	Laminated Steel	Grey
AL	Sheet Aluminium	Purple
MG	Magnesium	Brown
PL	Plastic	Blue
PL-R	Fiber Reinforced Plastic	Purple
CO	Composite Material	Blue

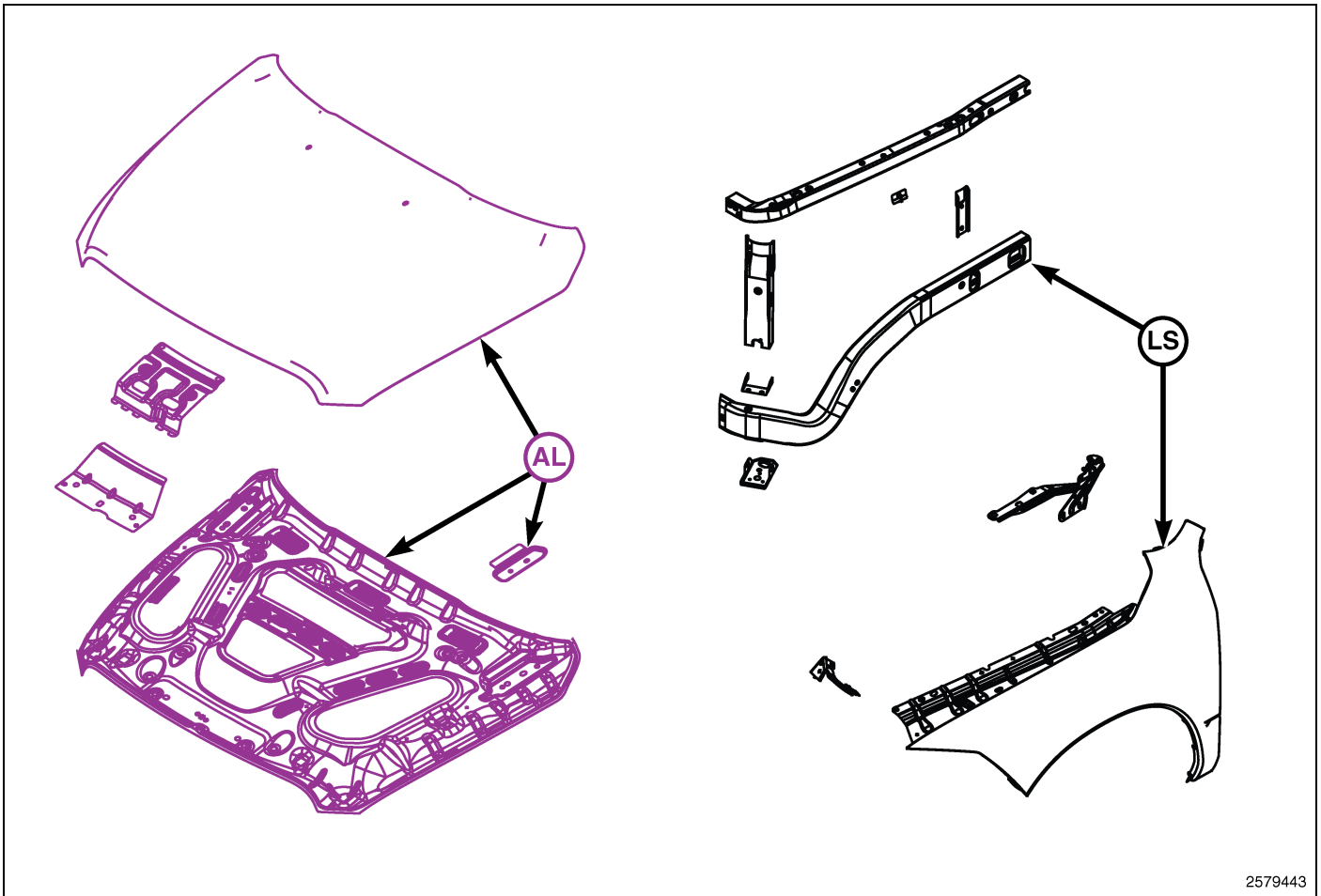

2579443

BODY IN WHITE COMPONENT IDENTIFICATION - FRONT END

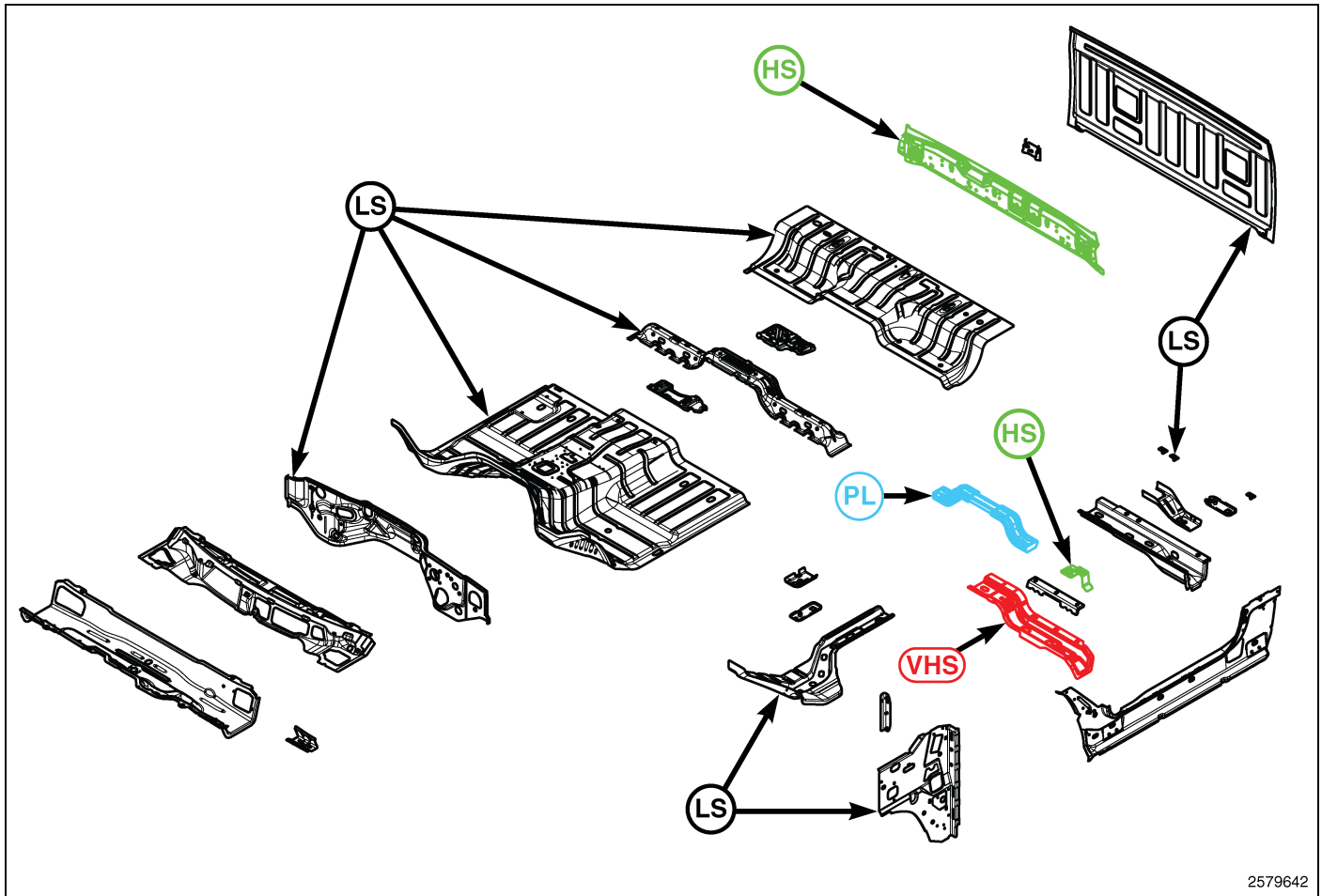

2579642

BODY IN WHITE COMPONENT IDENTIFICATION - UNDERBODY - STANDARD CAB

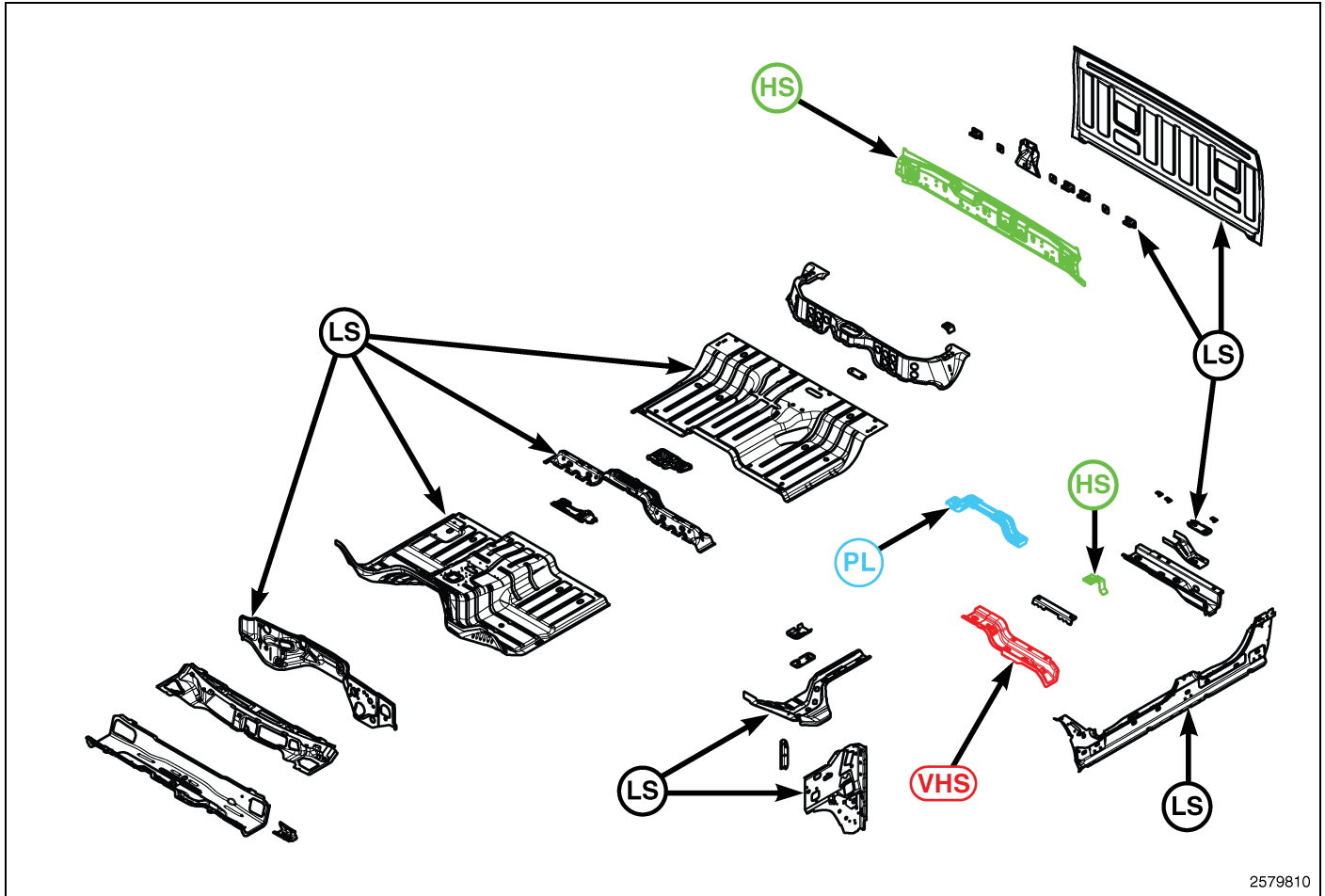

2579810

BODY IN WHITE COMPONENT IDENTIFICATION - UNDERBODY - QUAD CAB

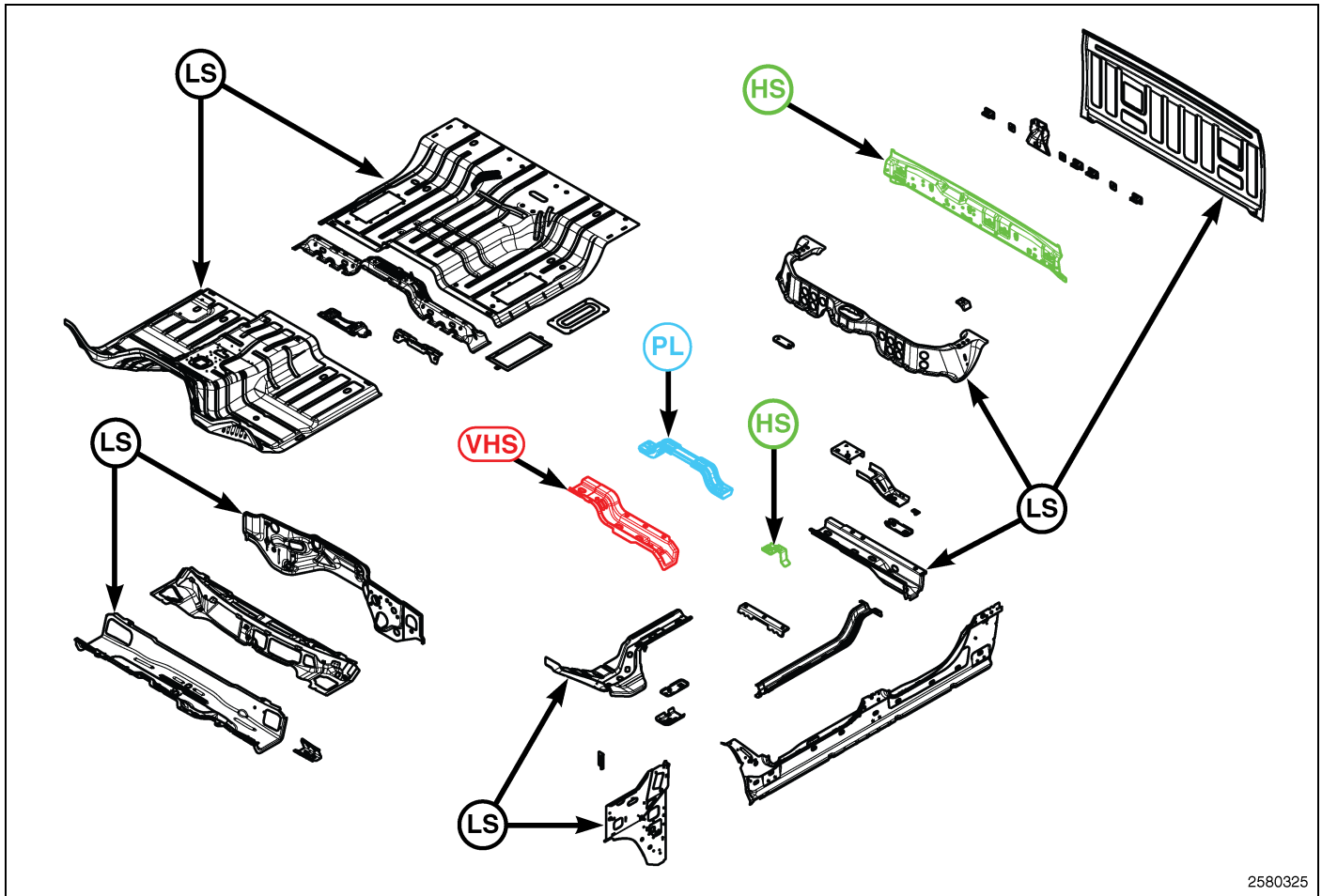

2580325

BODY IN WHITE COMPONENT IDENTIFICATION - UNDERBODY - CREW CAB

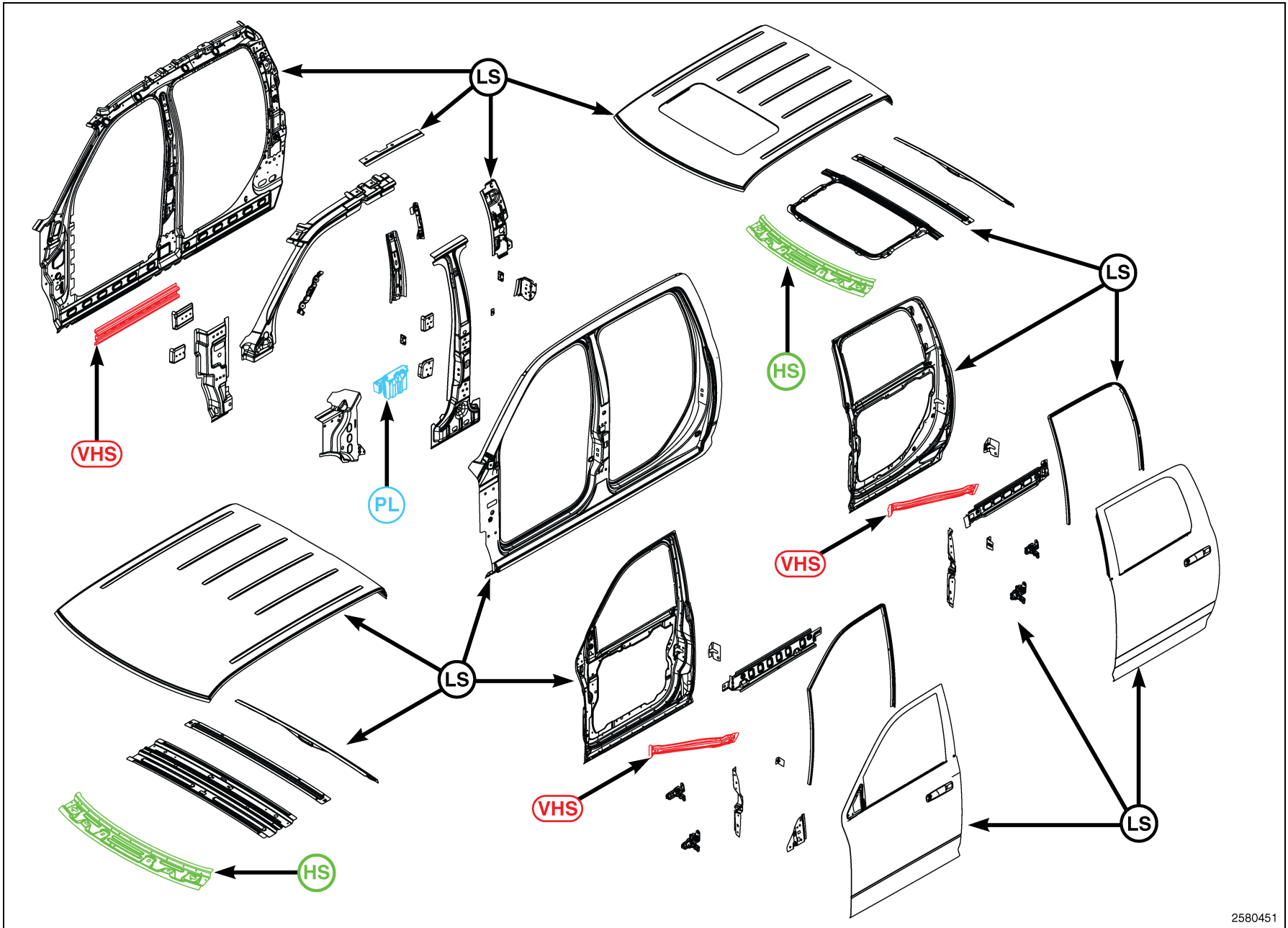

2580451

BODY IN WHITE COMPONENT IDENTIFICATION - BODY SIDE APERTURE, DOOR AND ROOF - CREW CAB

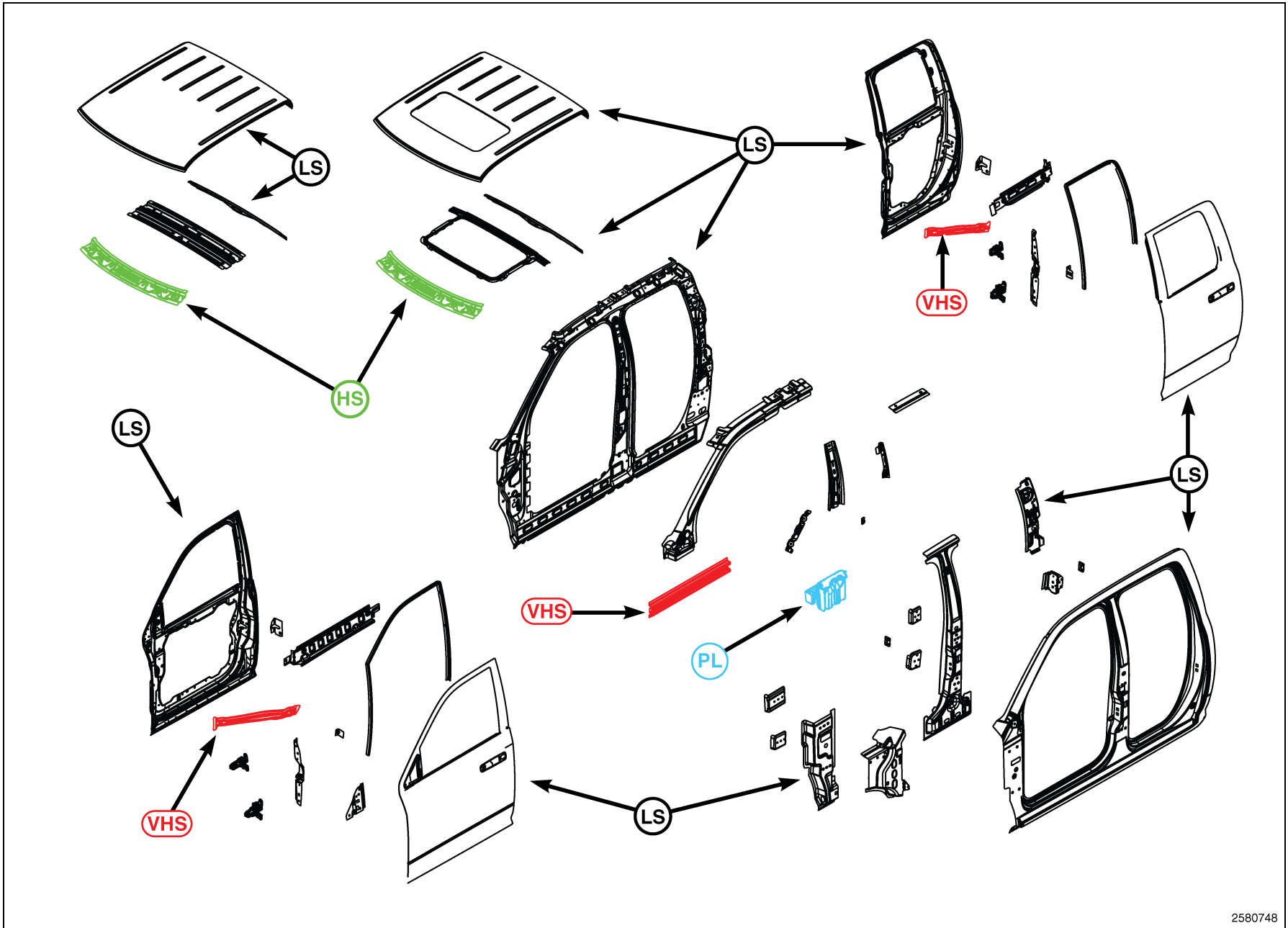

2580748

BODY IN WHITE COMPONENT IDENTIFICATION - BODY SIDE APERTURE, DOOR AND ROOF - QUAD CAB

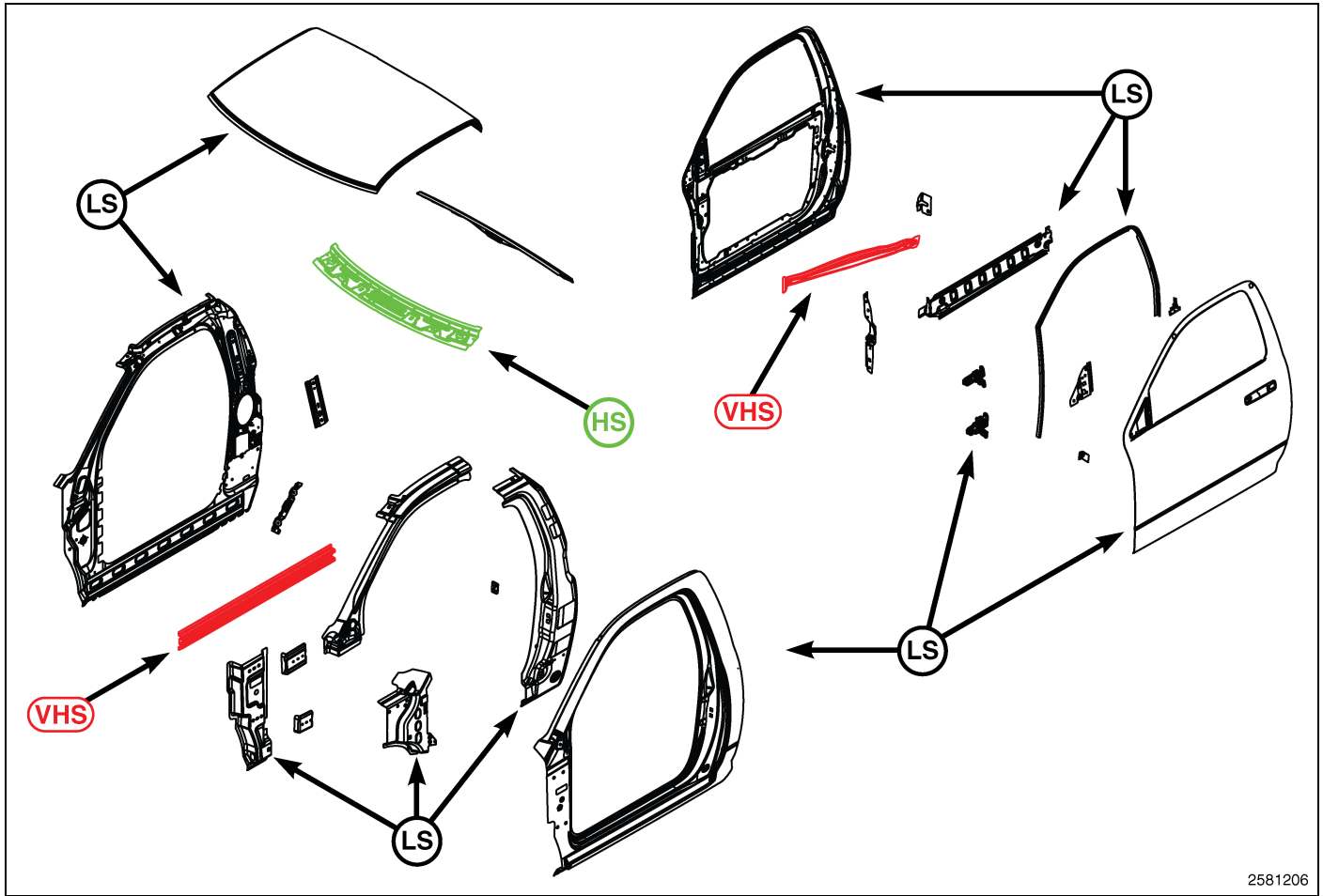

2581206

BODY IN WHITE COMPONENT IDENTIFICATION - BODY SIDE APERTURE, DOOR AND ROOF - STANDARD CAB

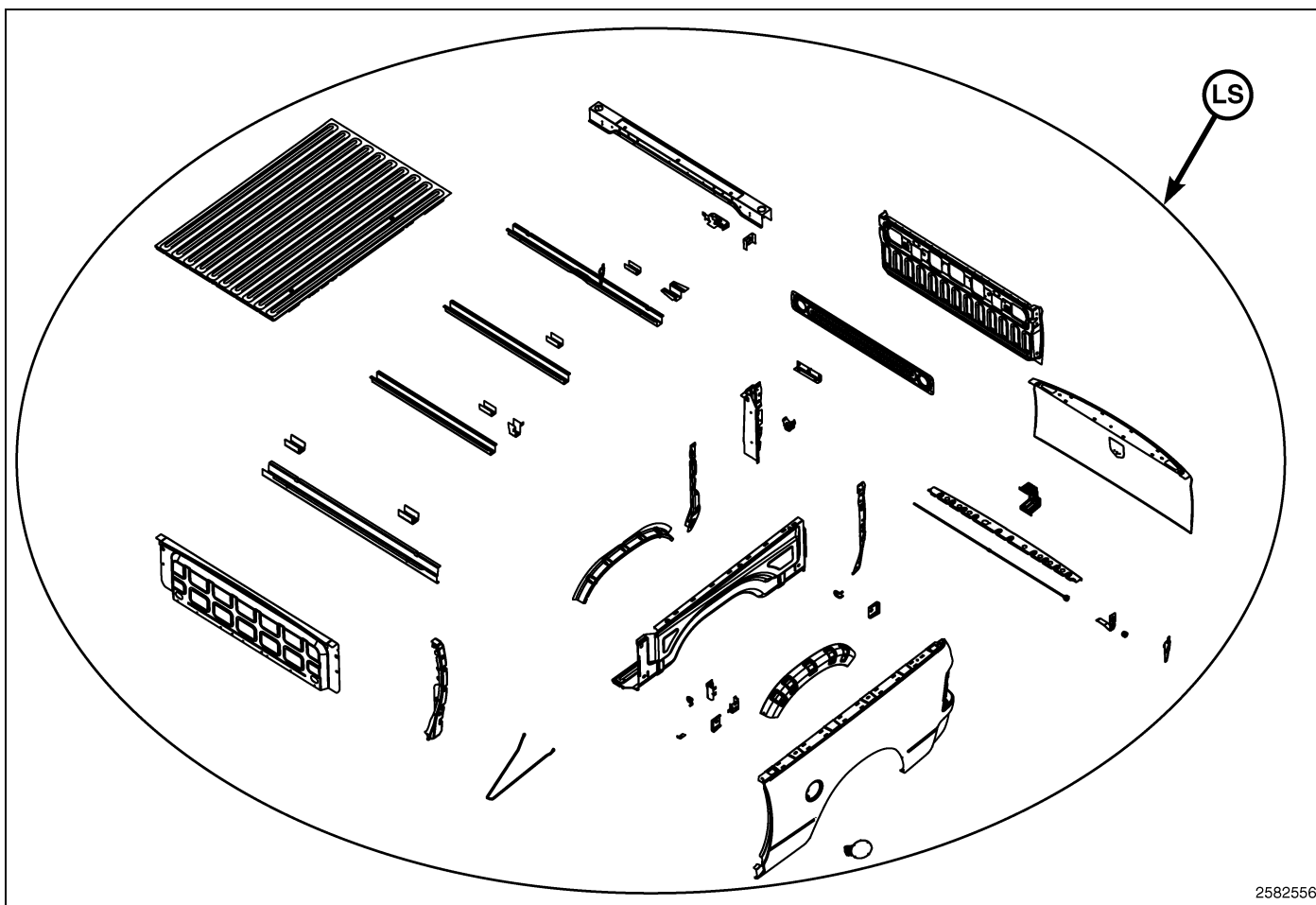

2582556

BODY IN WHITE COMPONENT IDENTIFICATION - PICKUP BOX - 6.3' SHOWN, 5.7' AND 8.0' TYPICAL, 5.7' RAMBOX SIMILAR

WELD PROCESS

COMPONENT PARTS	TRUCK FRAME		BODYSHELL EXTERIOR & UNDERBODY PANELS			
	Zinc and Zinc Iron Alloy coated sheet steels					
WELDING PROCESS	GAS METAL ARC (Note: 1)	FLUX CORED ARC	GAS METAL ARC (Note: 1)	MIG BRAZE (Note: 2)	GAS METAL ARC (Note: 1)	FLUX CORED ARC
Material Type	High Strength and Structural Quality Steels which includes HSLA, Martensitic, and Dual Phase materials					
Material Thickness Range	2 mm - 4 mm		0.6 mm - 1.02 mm		>1.02 mm - 3.0 mm	
ELECTRODE TYPE (AWS SPEC. A5.18)	AWS CLASS. ER70S-6	AWS CLASS. E71T-11 (Note 3)	AWS CLASS. ER70S-6	AWS CLASS. ERCuSi - A Silicon Bronze	AWS CLASS. ER70S-6	AWS CLASS. E71T-11 (Note 3)
ELECTRODE SIZE	0.035	0.045	0.023 - 0.025	0.035	0.035	0.045
ELECTRODE MAKER	Lincoln®	Lincoln® NR-211-MP	Lincoln®		Lincoln®	Lincoln® NR-211-MP

COMPONENT PARTS	TRUCK FRAME		BODYSHELL EXTERIOR & UNDERBODY PANELS			
WIRE FEED SPEED (in/min)	245-250 Vertical Down 70-90 Flat & Horizontal	110 Vertical Down 70-90 Flat & Horizontal	95-115 All Welds	150-155 Flat & Horizontal	245-250 Vertical Down 70-90 Flat & Horizontal	110 Vertical Down 70-90 Flat & Horizontal
TRAVEL SPEED (in/min)			10			
VOLTAGE	19-20	15-18	16-19	18-19	19-20	15-18
POLARITY	DCEP	DCEN	DCEP	DCEP	DCEP	DCEN
GAS FLOW (cfh)	25-35	N/A	25-35	25-35	25-35	N/A
ELECTRICAL STICKOUT (in)	1/2 - 5/8	3/8 - 1/2	1/2 - 5/8	5/8 - 3/4	1/2- 5/8	3/8 - 1/2
GAS TYPE	75% Ar 25% CO2	N/A	75% Ar 25% CO2	100% Ar	75% Ar 25% CO2	N/A
TYPE OF ARC TRANSFER	Short Circuit		Short Circuit	Pulse	Short Circuit	

These Procedure Specifications are appropriate as of this publication. Procedures may be superseded with new spec's at a later date.

Always process to the thinner material thickness (TMT)

All persons performing welding must be qualified to weld in all positions.

NOTE:

1. Must remove Zinc Coating on both sides of metal at the weld zone.
2. MIG Braze welding process requires use of Pulse Arc® or STT® welding machine.
3. Must use Lincoln® product since E 71T-11 product differs from other suppliers.

BODY OPENING DIMENSIONS

BODY OPENING DIMENSIONS INDEX

DESCRIPTION	FIGURE
Engine Compartment/Body Structure	(Fig. 1)
Windshield Opening - All	(Fig. 2)
Door Openings – Standard Cab	(Fig. 3)
Door Openings – Quad Cab	(Fig. 4)
Door Openings – Crew Cab	(Fig. 5)
Rear Window Opening - All	(Fig. 6)
Pickup Box – 5.7' Ram Box (Plan View)	(Fig. 7)
Pickup Box – 5.7' Box (Plan View)	(Fig. 8)
Pickup Box – 6.3' Box (Plan View)	(Fig. 9)
Pickup Box – 8.0' Box (Plan View)	(Fig. 10)
Pickup Box – Tail Gate Opening - All	(Fig. 11)

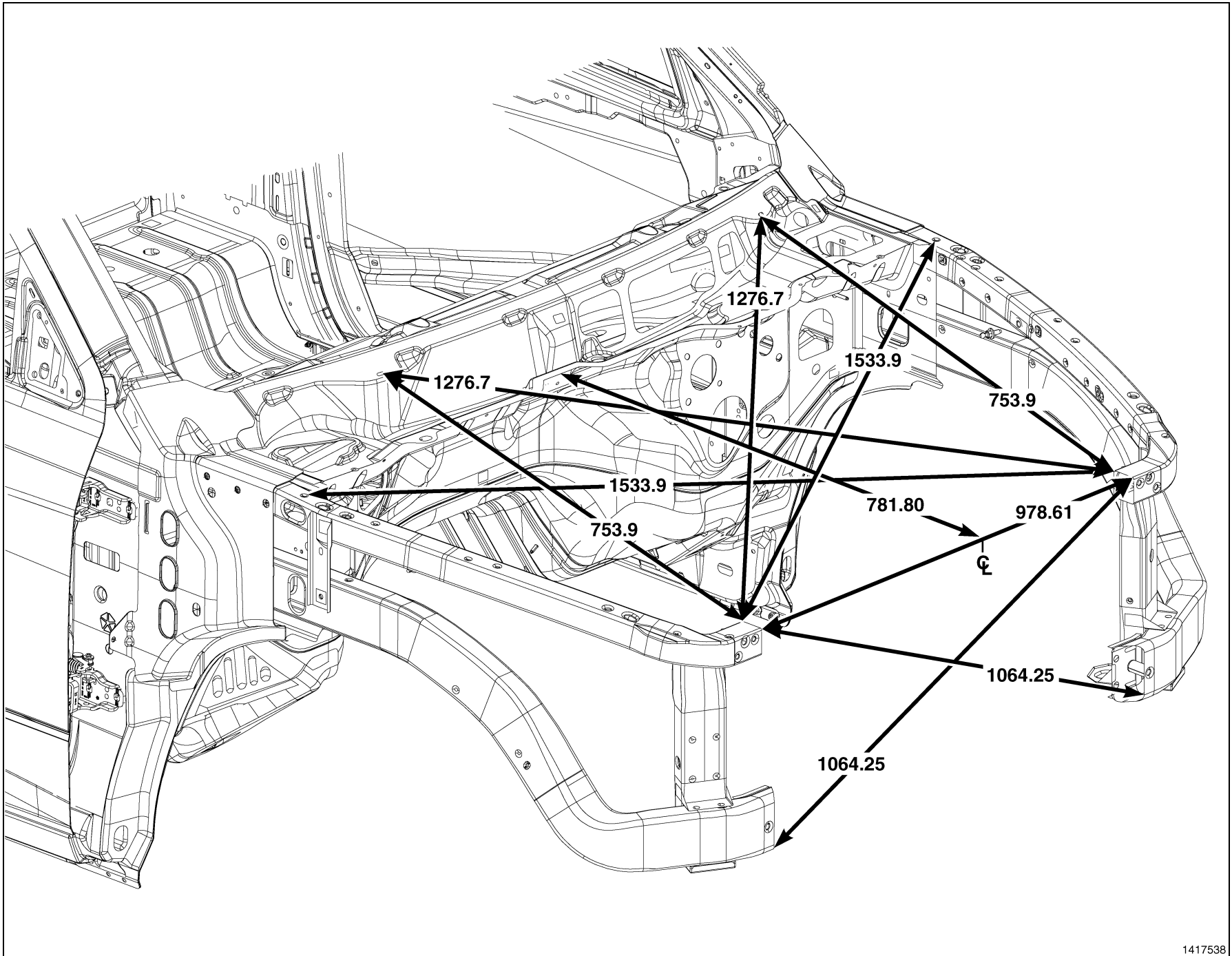

1417538

Fig. 1 Engine Compartment/Body Structure

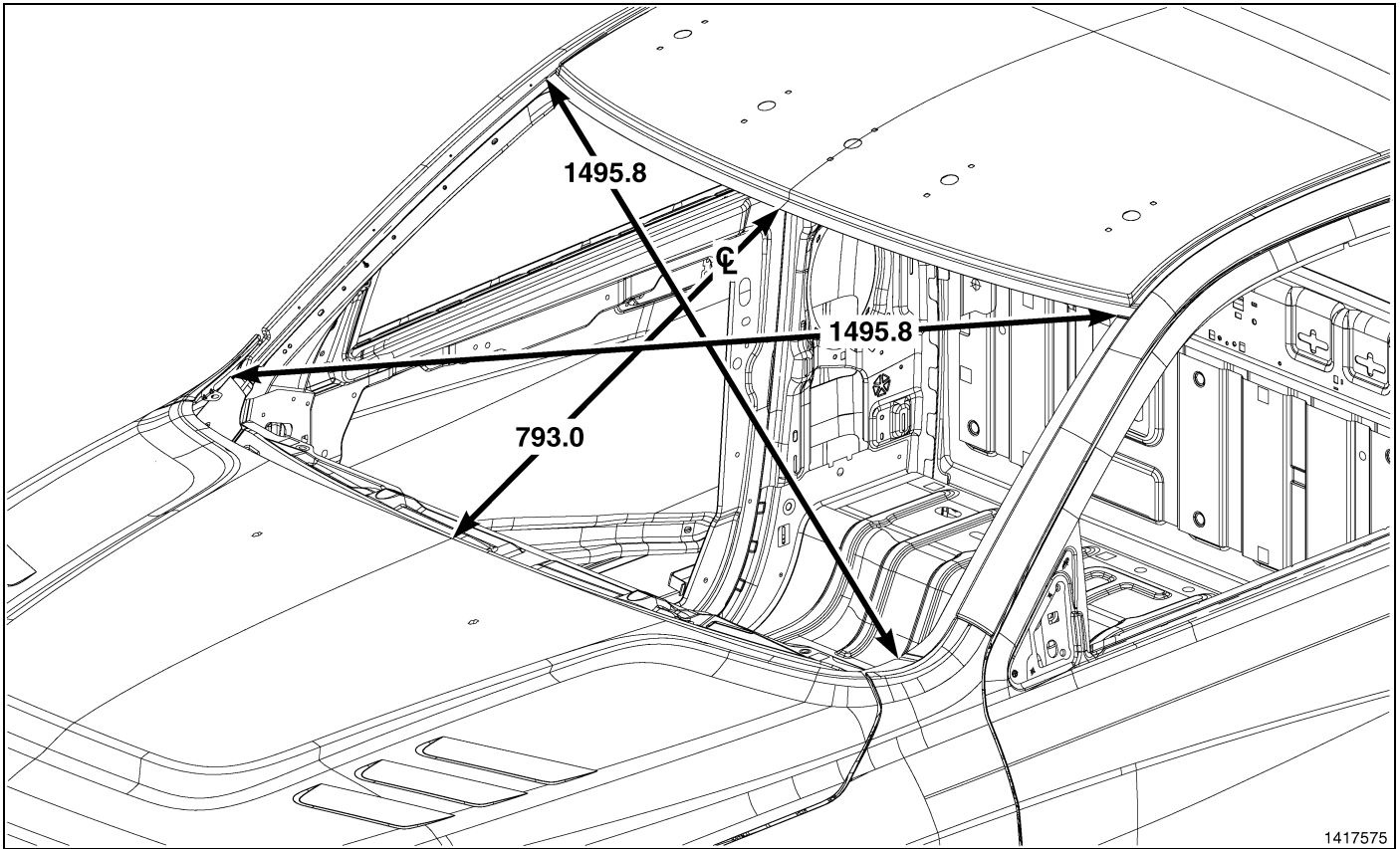

1417575

Fig. 2 Windshield Opening - All

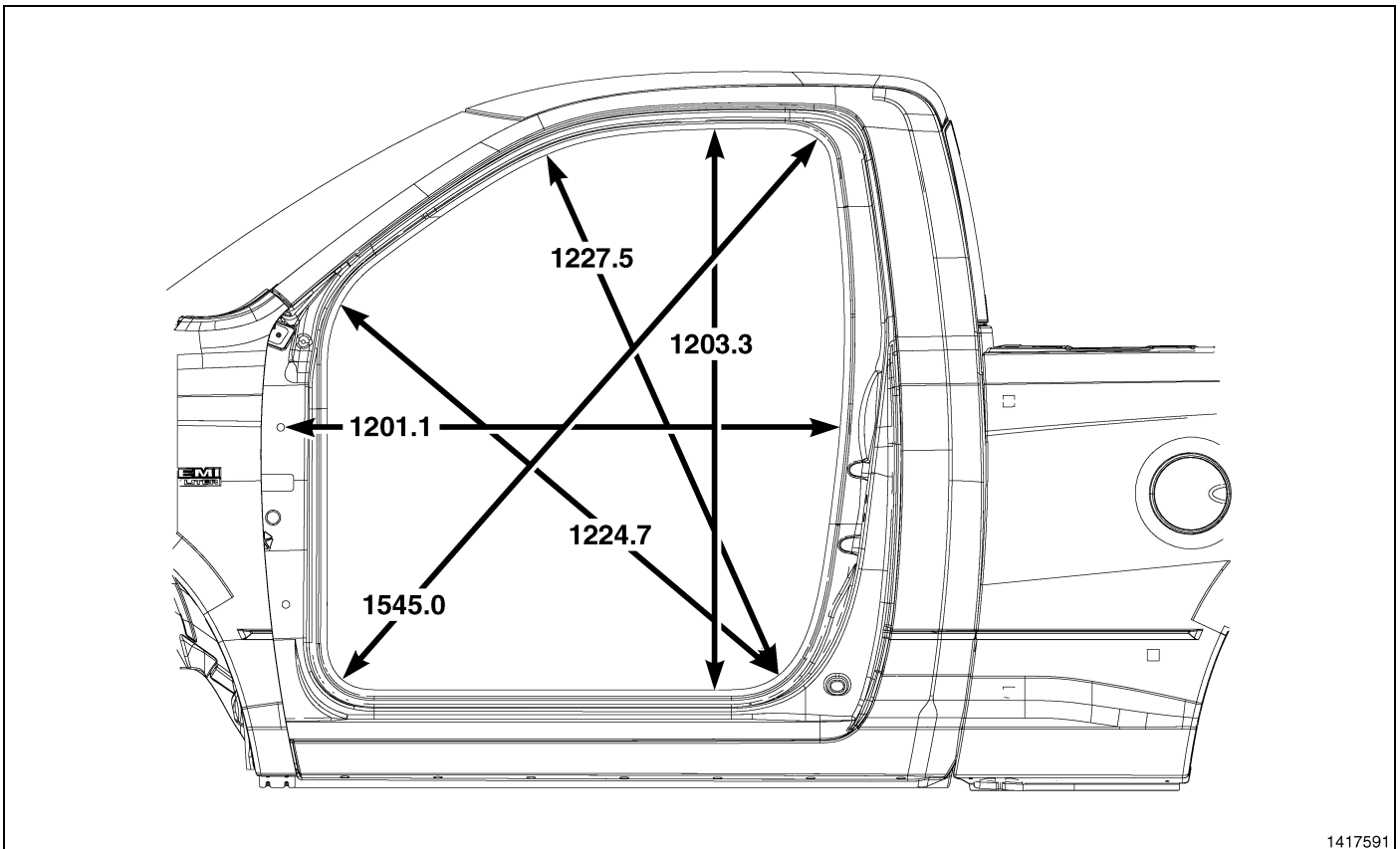

1417591

Fig. 3 Door Openings – Standard Cab

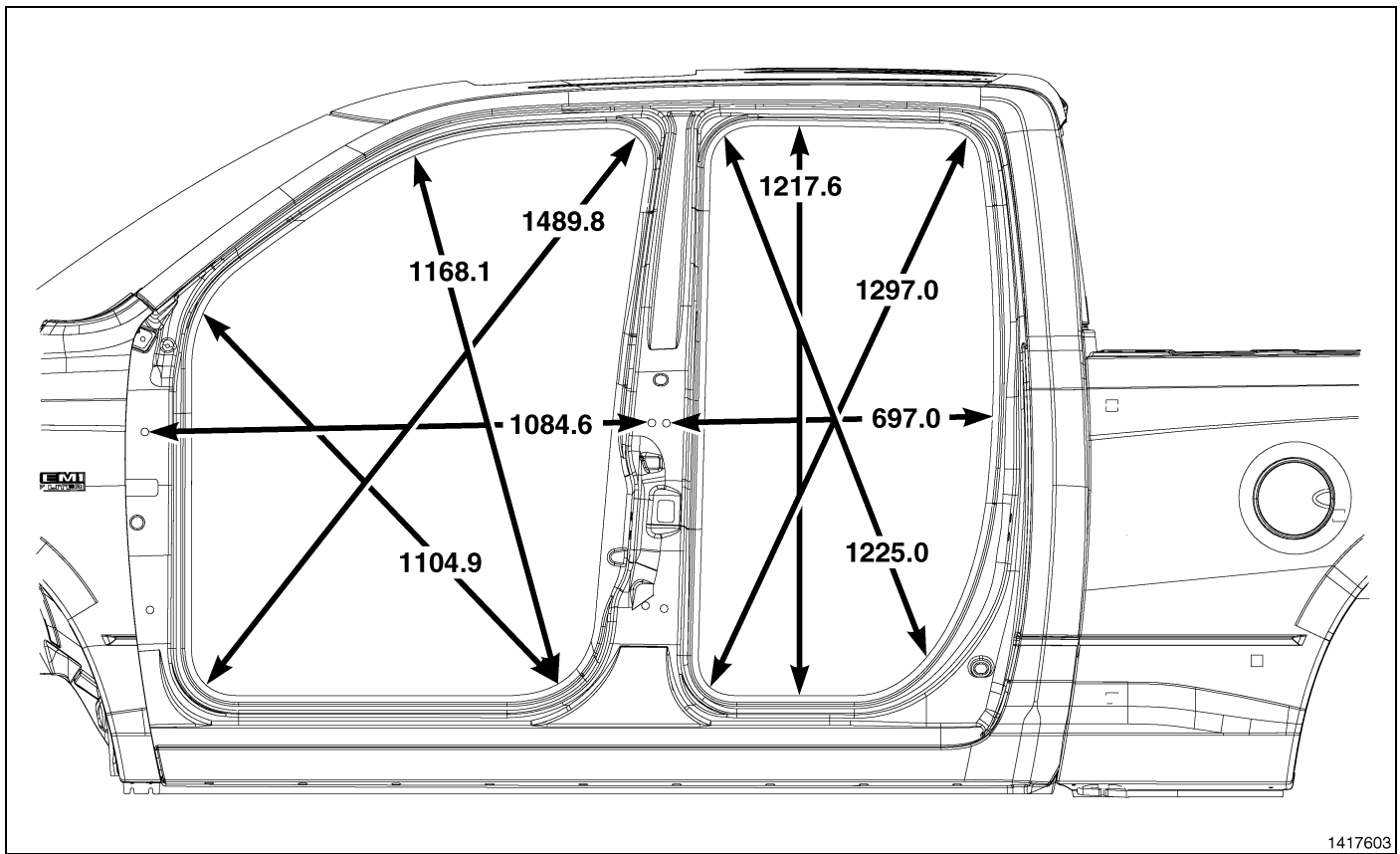

1417603

Fig. 4 Door Openings – Quad Cab

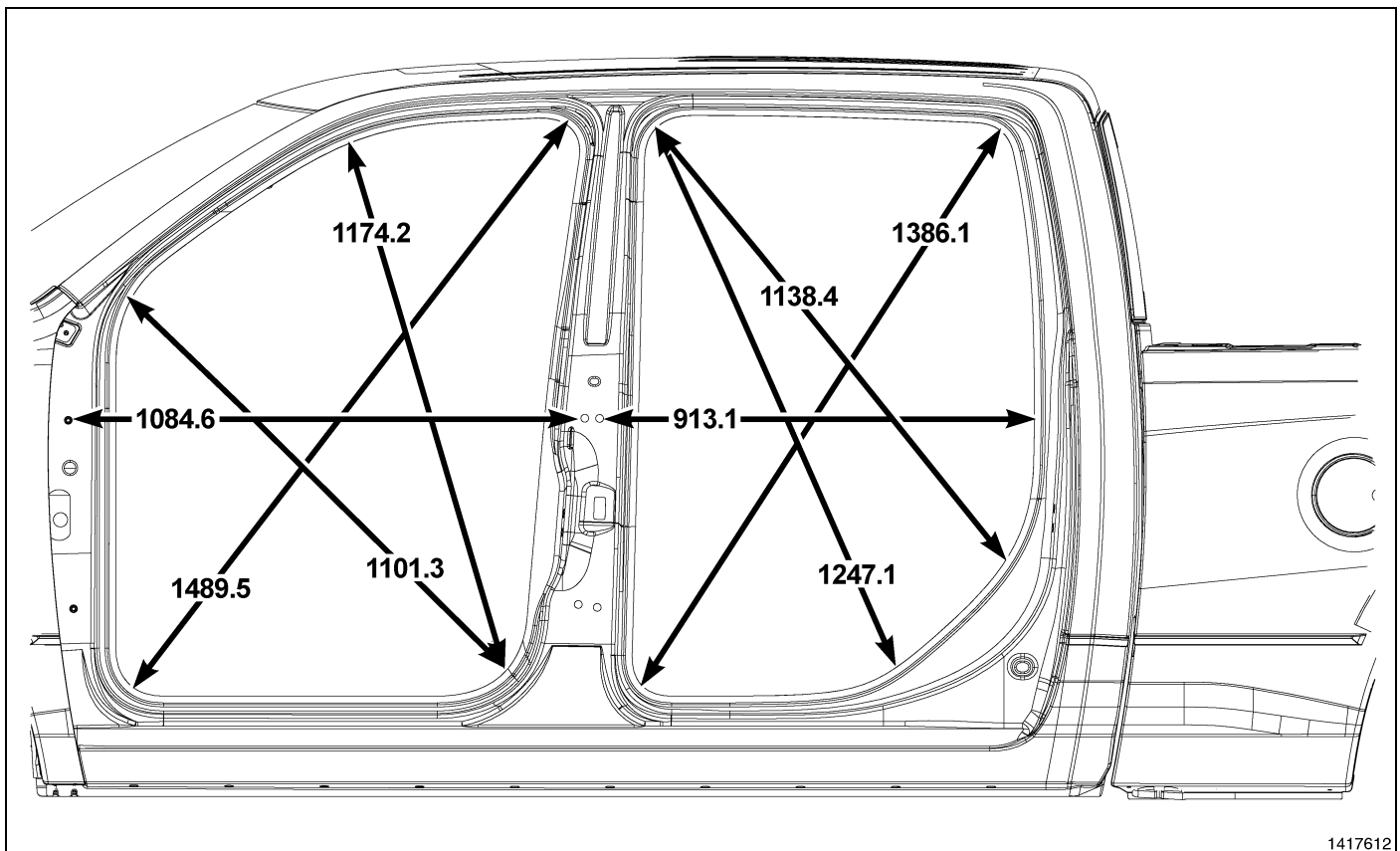

1417612

Fig. 5 Door Openings – Crew Cab

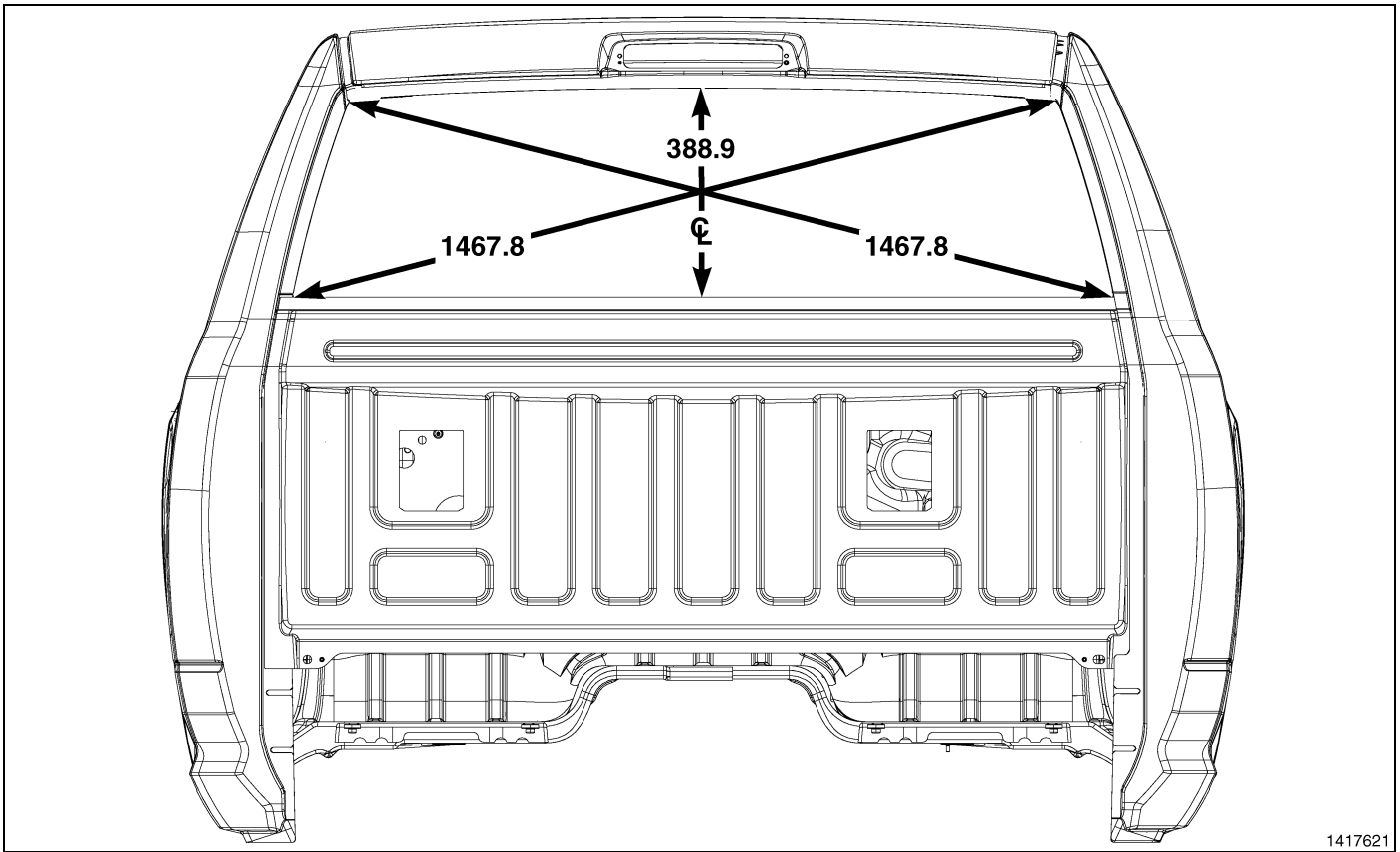

1417621

Fig. 6 Rear Window Opening - All

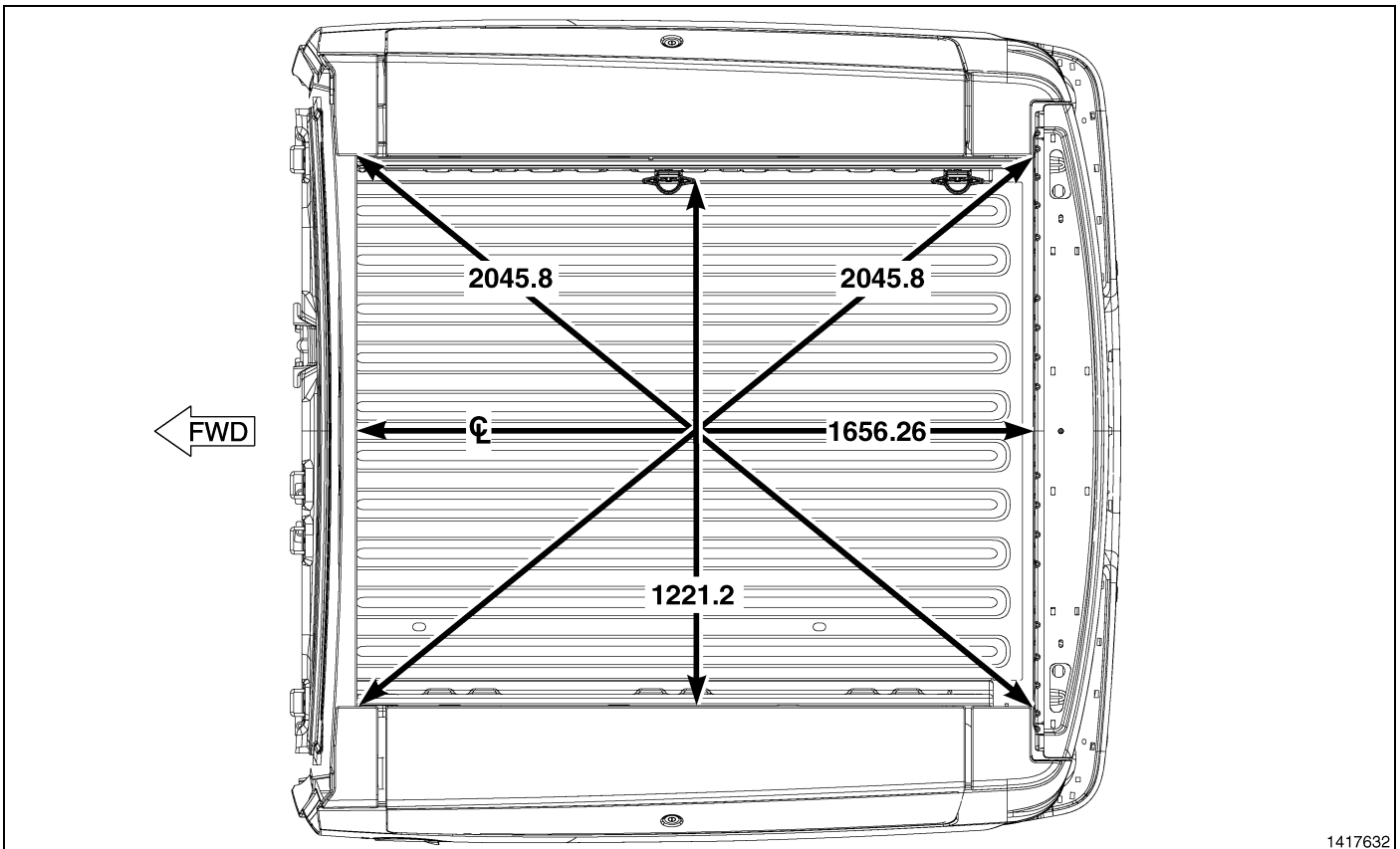

1417632

Fig. 7 Pickup Box - 5.7' Ram Box (Plan View)

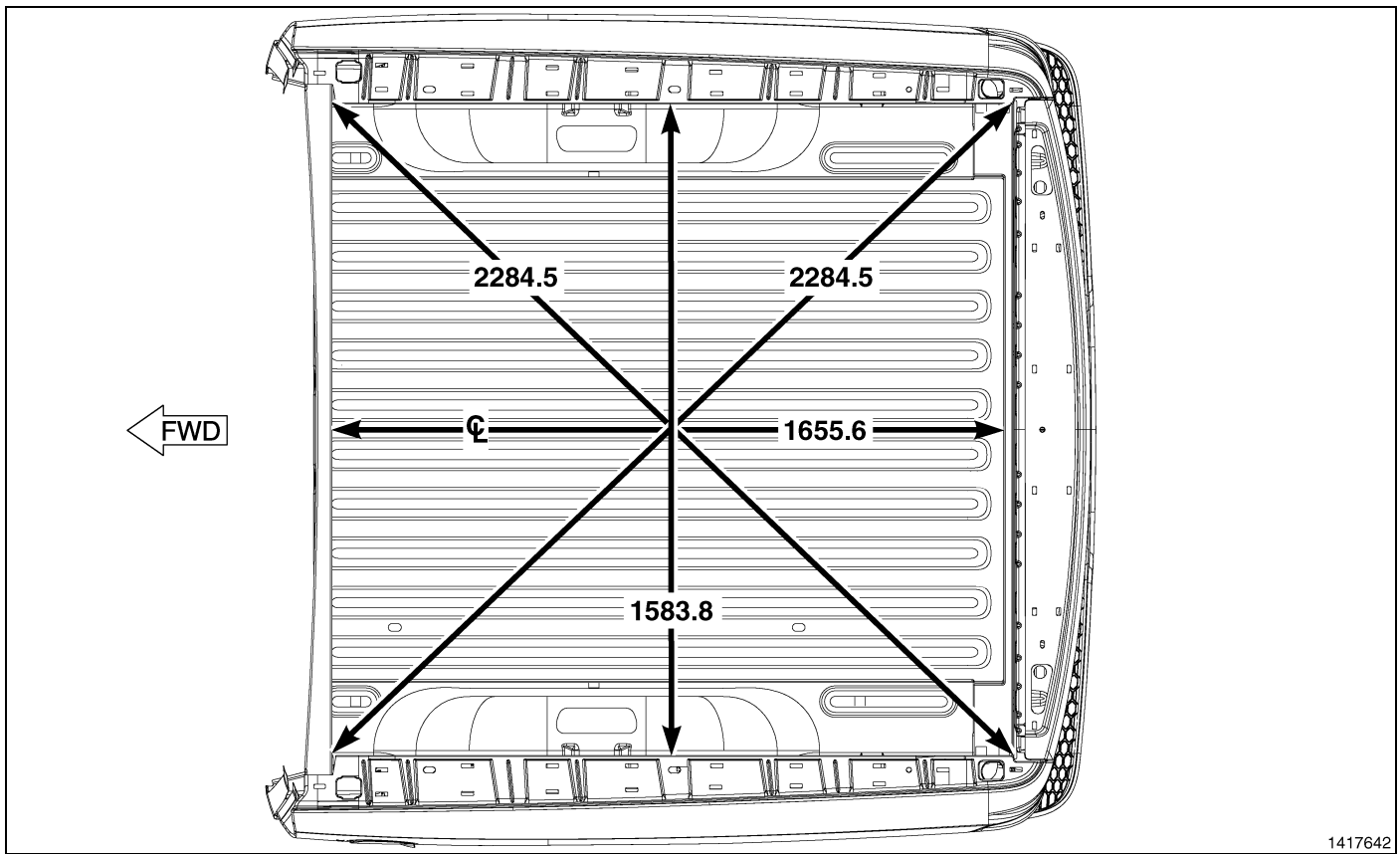

Fig. 8 Pickup Box – 5.7' Box (Plan View)

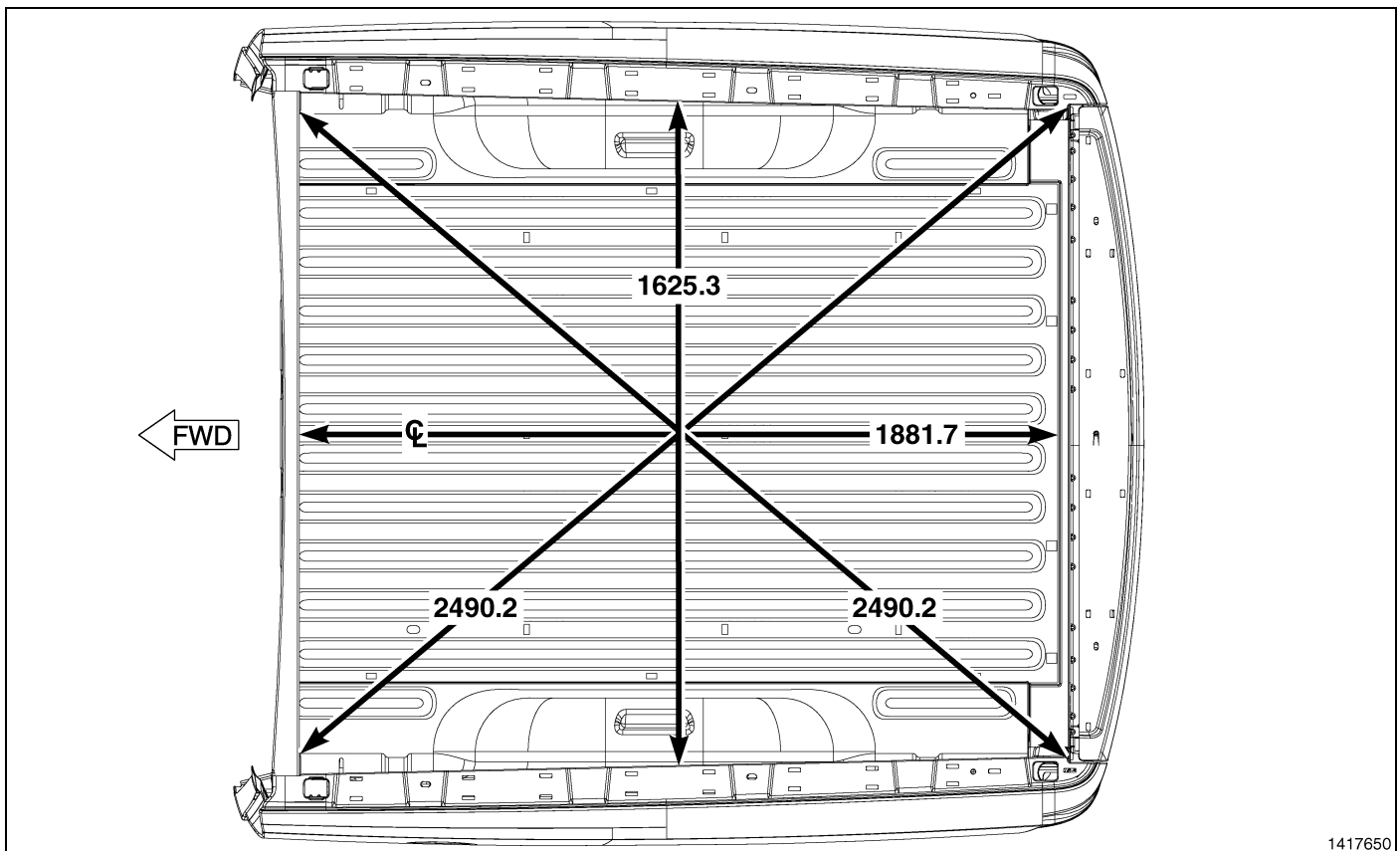
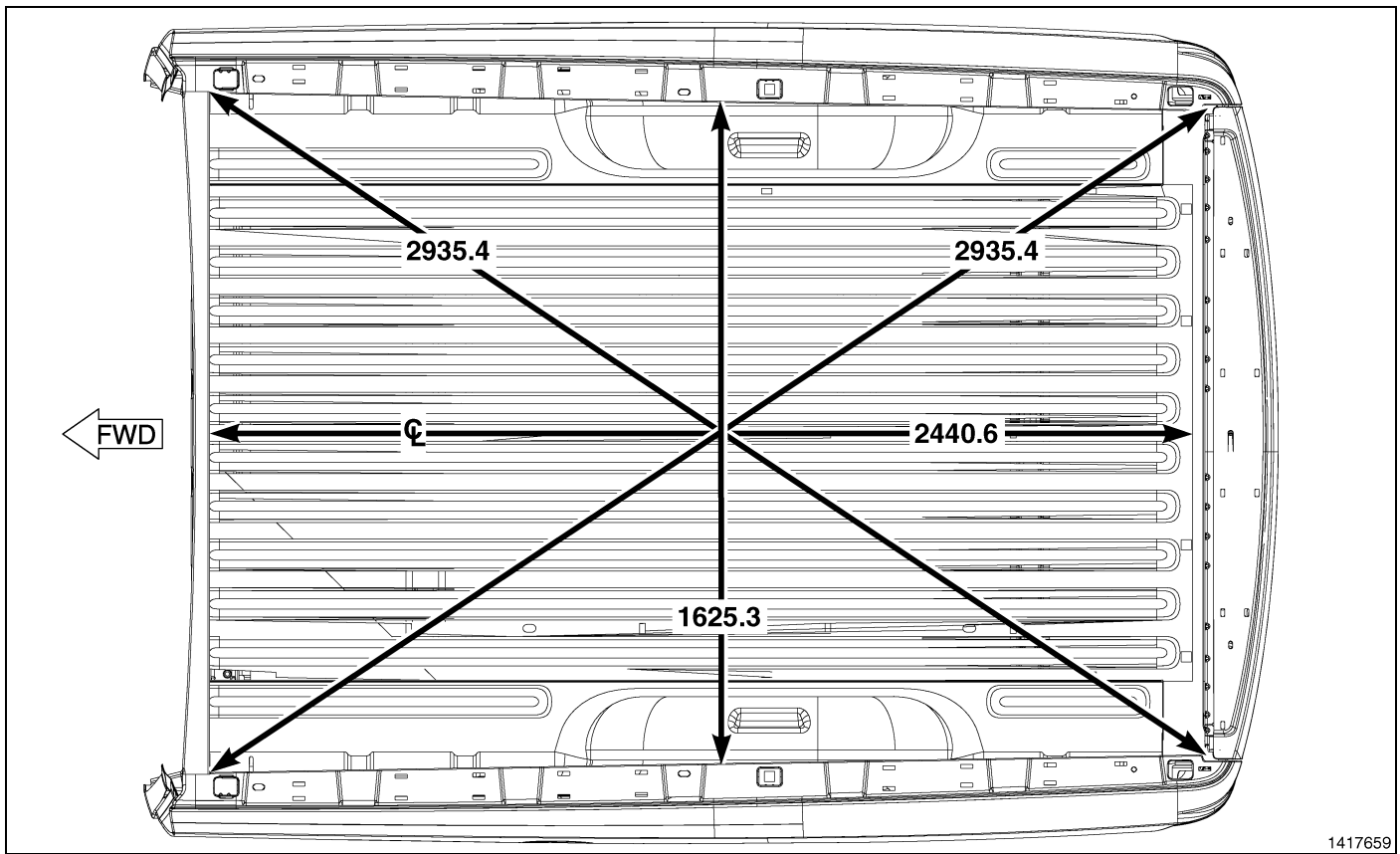
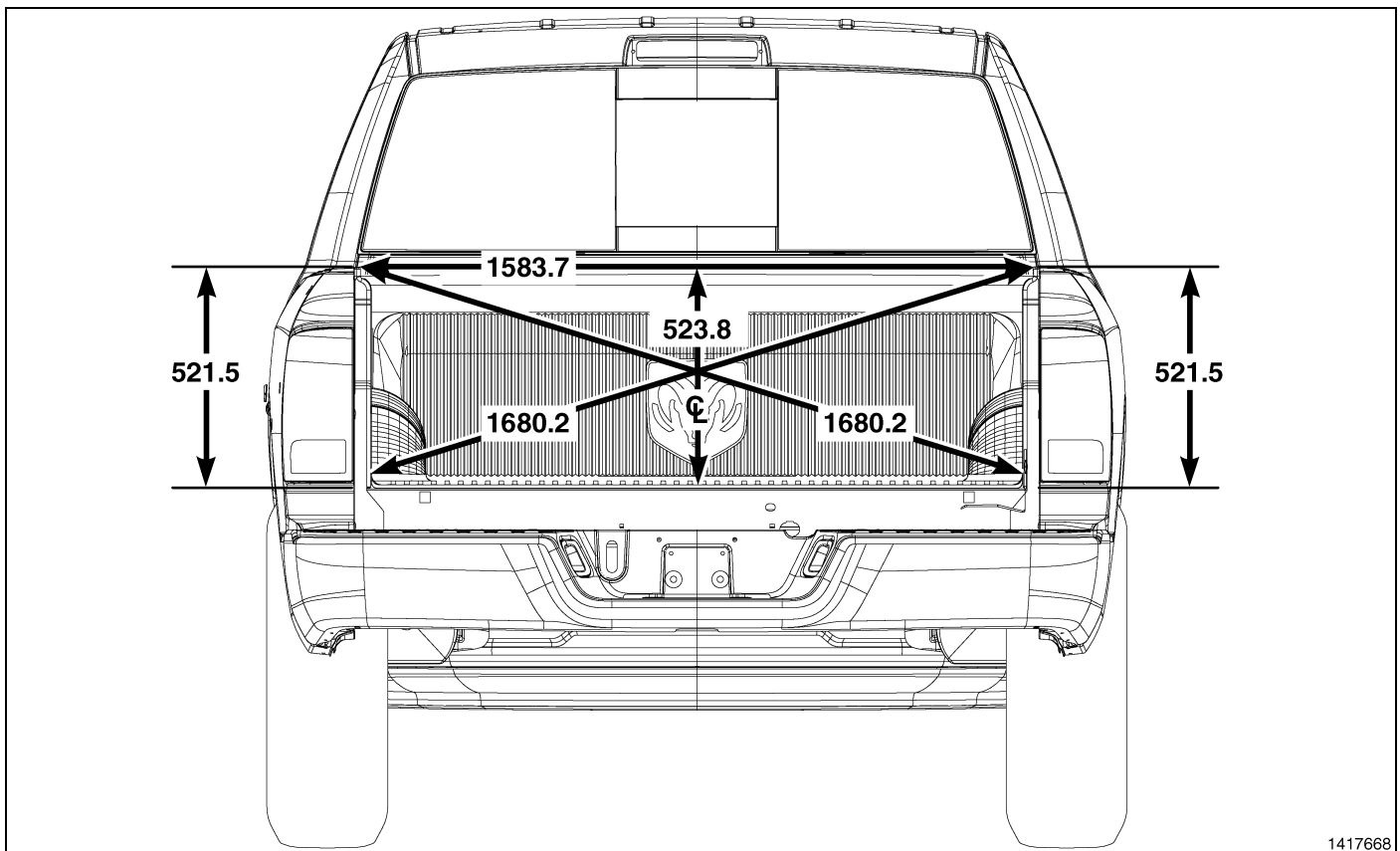

Fig. 9 Pickup Box – 6.3' Box (Plan View)



1417659

Fig. 10 Pickup Box – 8.0' Box (Plan View)



1417668

Fig. 11 Pickup Box – Tail Gate Opening - All

FRAME DIMENSIONS

NOTE: Frame dimensions are listed in metric scale. All dimensions are from center to center of Principal Locating Point (PLP), or from center to center of PLP and fastener location.

VEHICLE PREPARATION

Position the vehicle on a level work surface. Using screw or bottle jacks, adjust the vehicle PLP heights to the specified dimension above a level work surface. Vertical dimensions can be taken from the work surface to the locations indicated were applicable.

INDEX

DESCRIPTION	FIGURE
Front View – All	
120.5 In. Wheelbase – Regular Cab – 6.3 Ft. Box	(Fig. 13)
140.5 In. Wheelbase – Regular Cab – 8.0 Ft. Box	(Fig. 14)
140.5 In. Wheelbase – Quad Cab – 6.3 Ft. Box	(Fig. 15)
140.5 In. Wheelbase – Crew Cab – 5.7 Ft. Box	(Fig. 16)

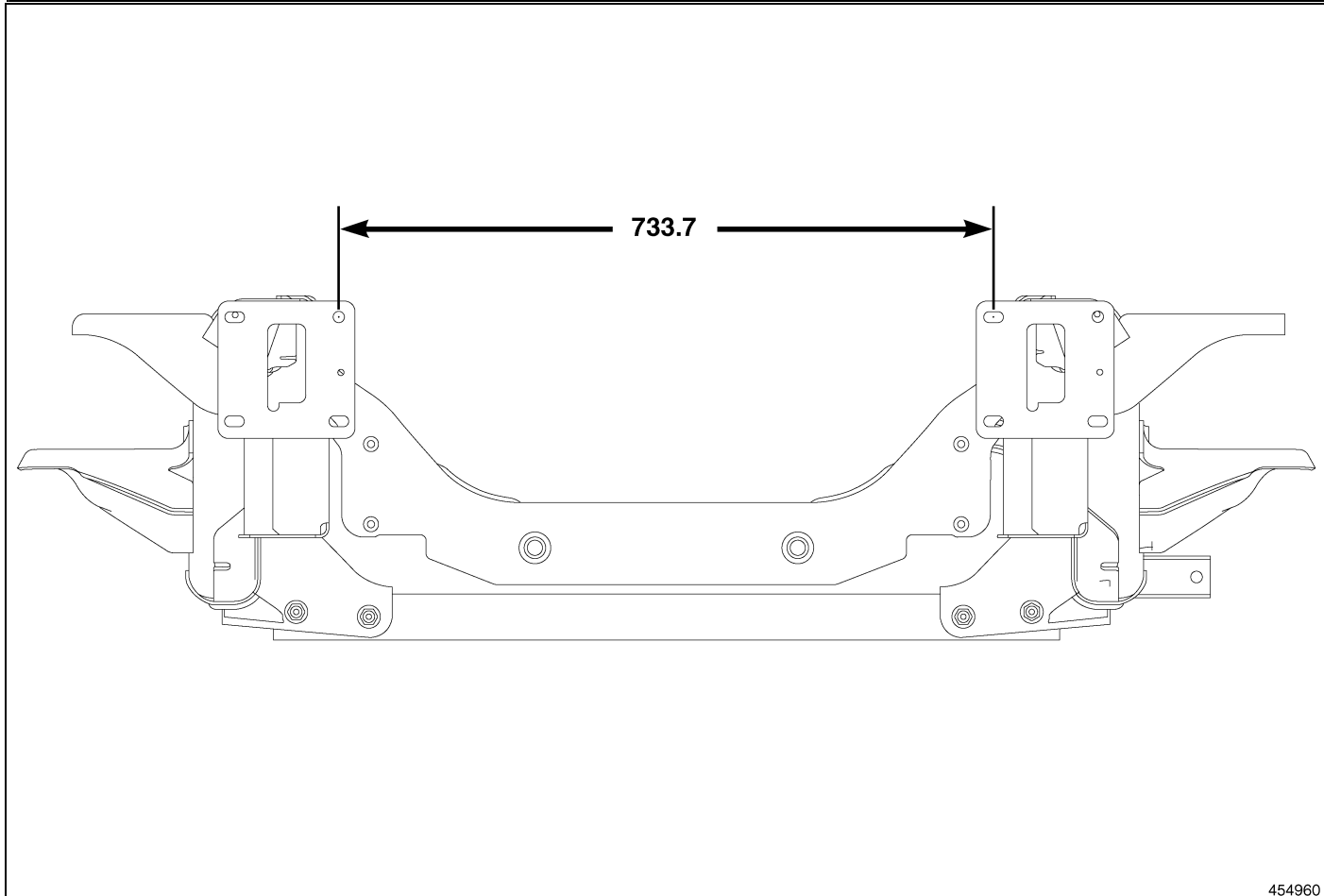

454960

Fig. 12 Front View – All

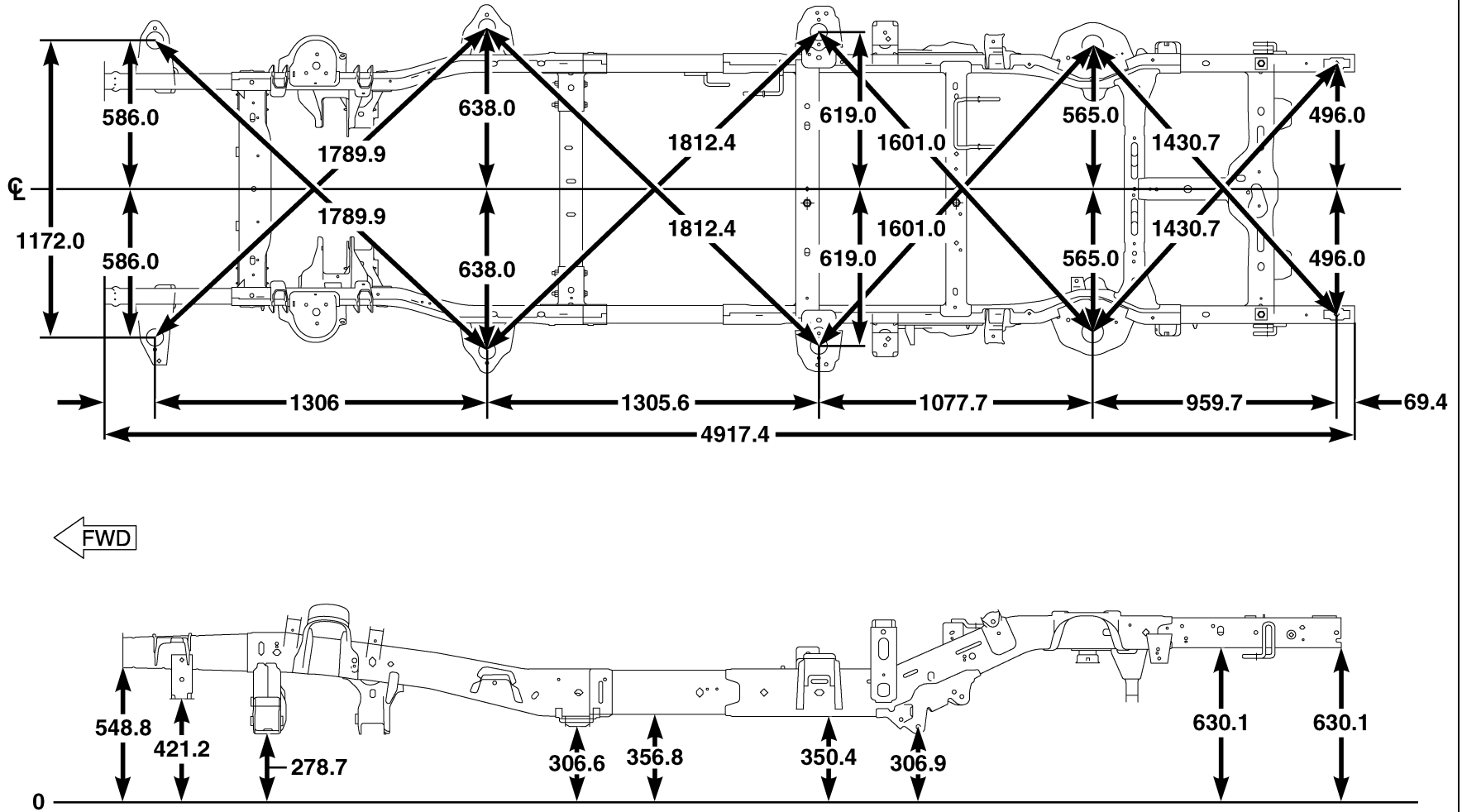

454928

Fig. 13 120.5 In. Wheelbase – Regular Cab – 6.3 Ft. Box

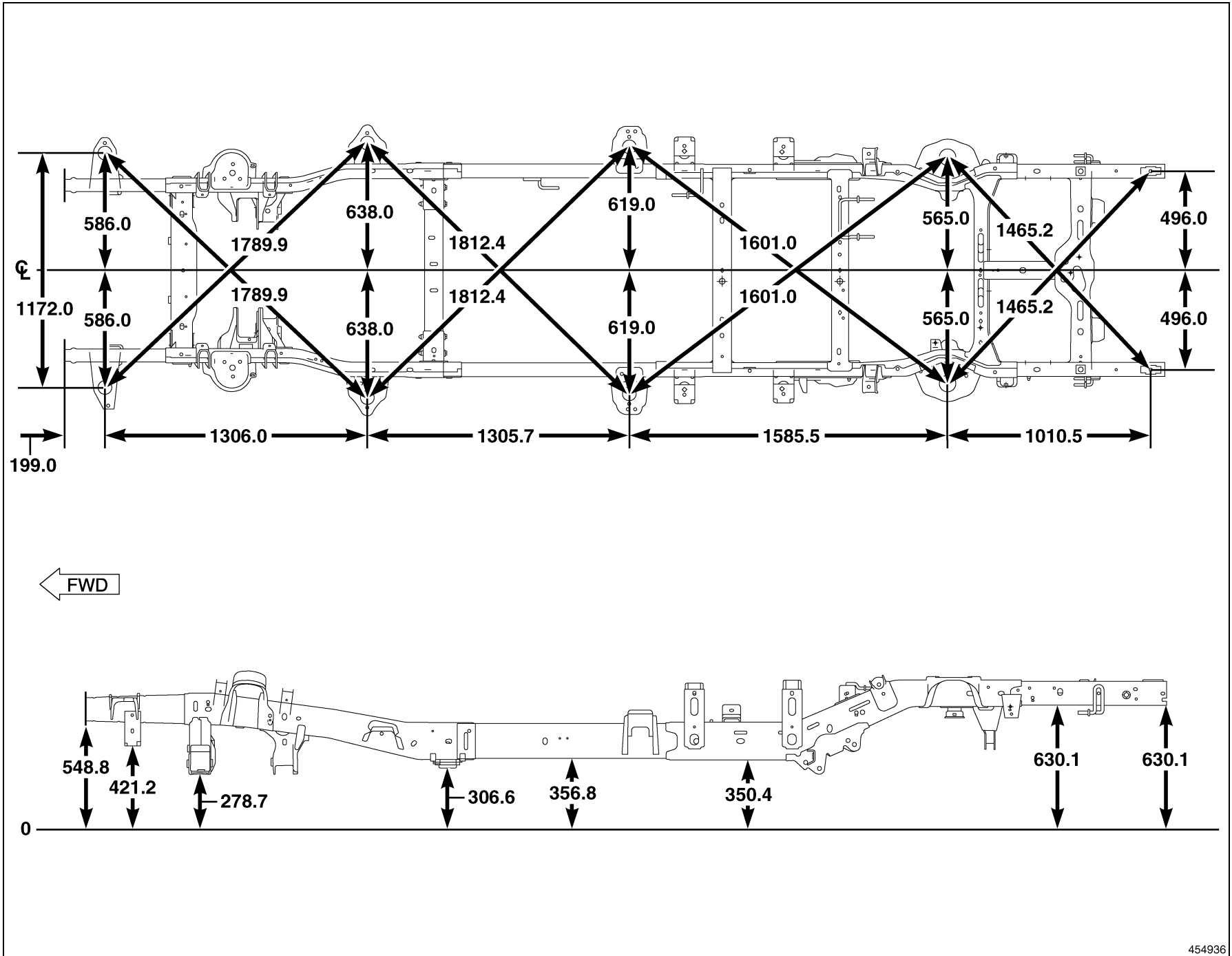

454936

Fig. 14 140.5 In. Wheelbase – Regular Cab – 8.0 Ft. Box

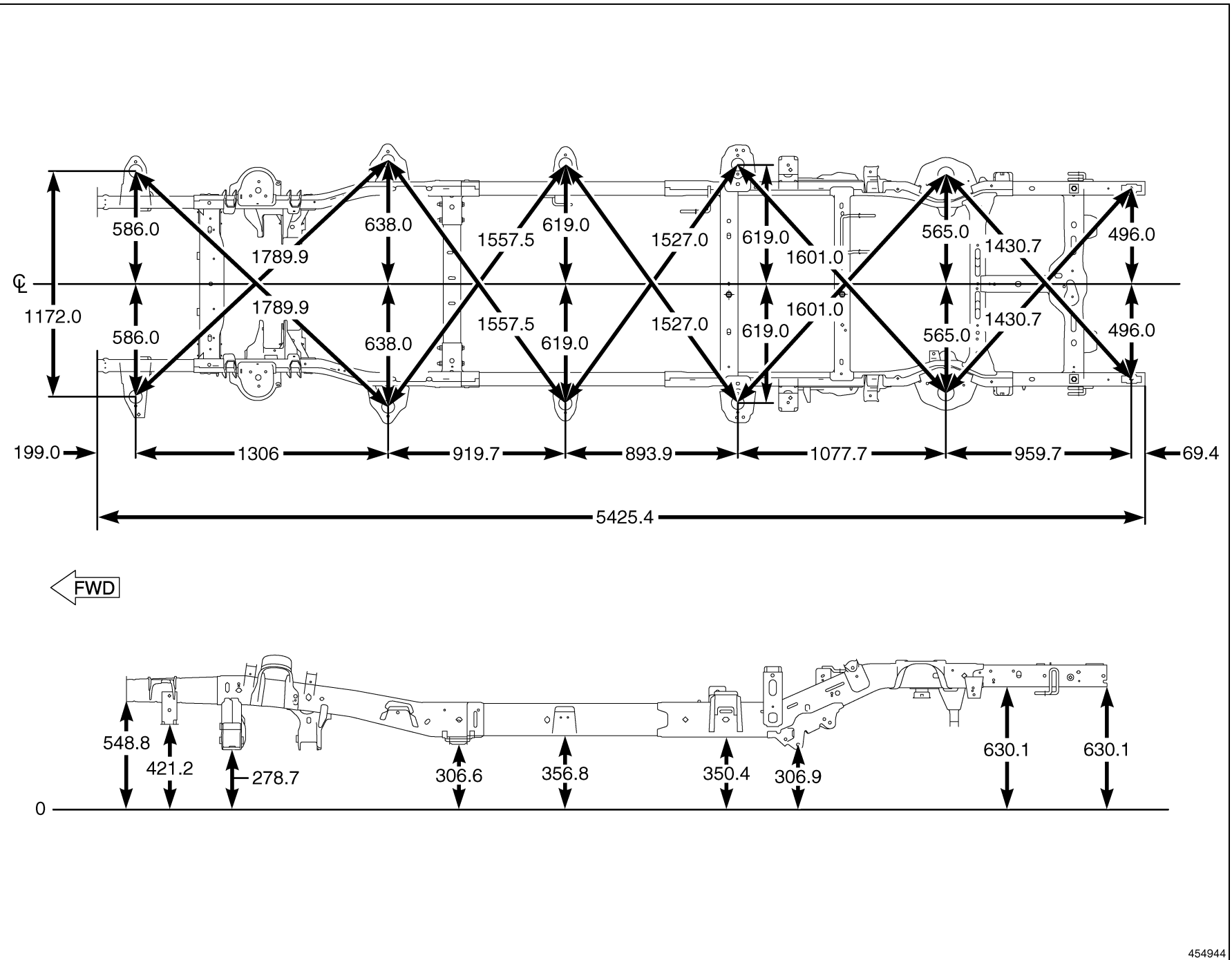

454944

Fig. 15 140.5 In. Wheelbase – Quad Cab – 6.3 Ft. Box

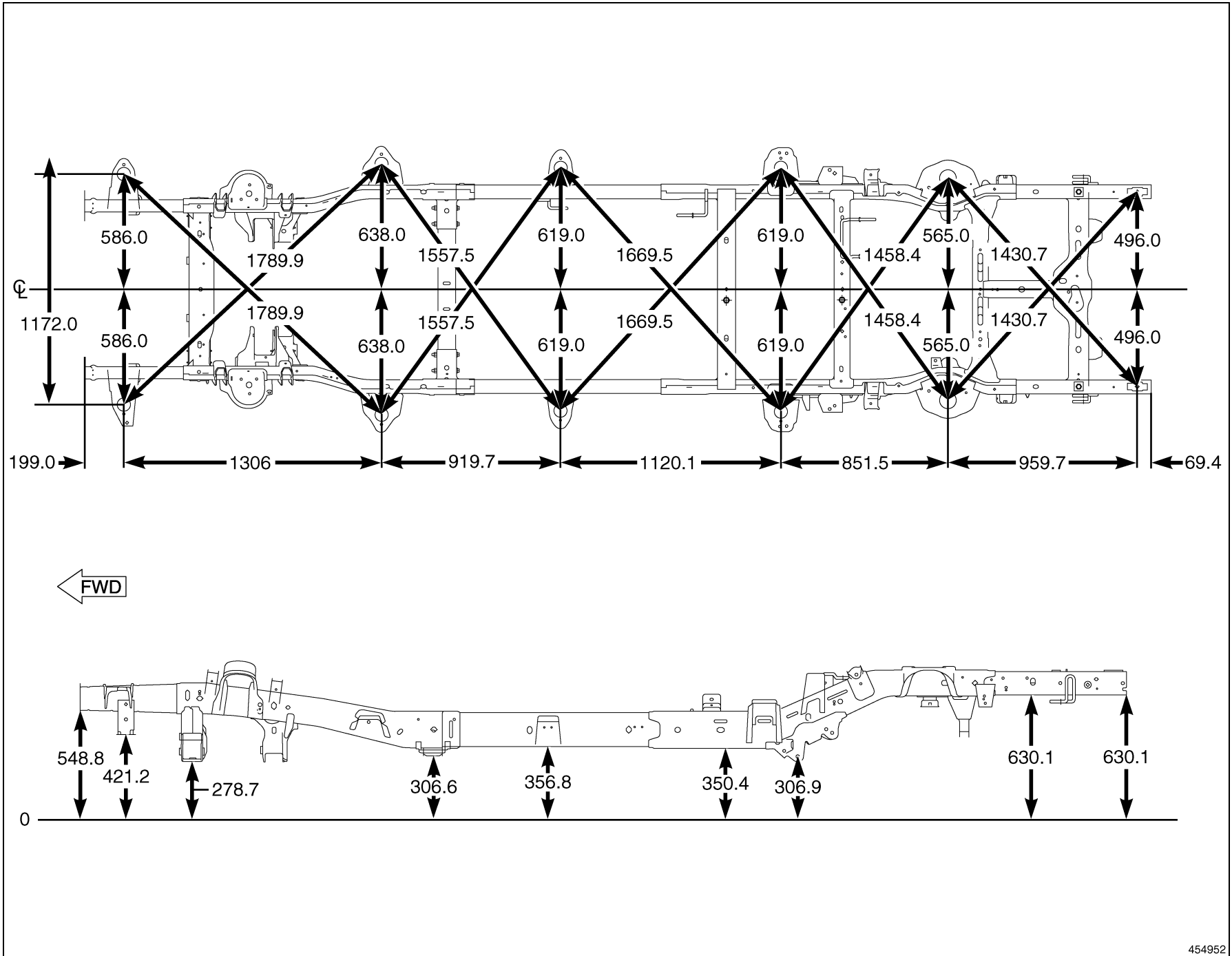
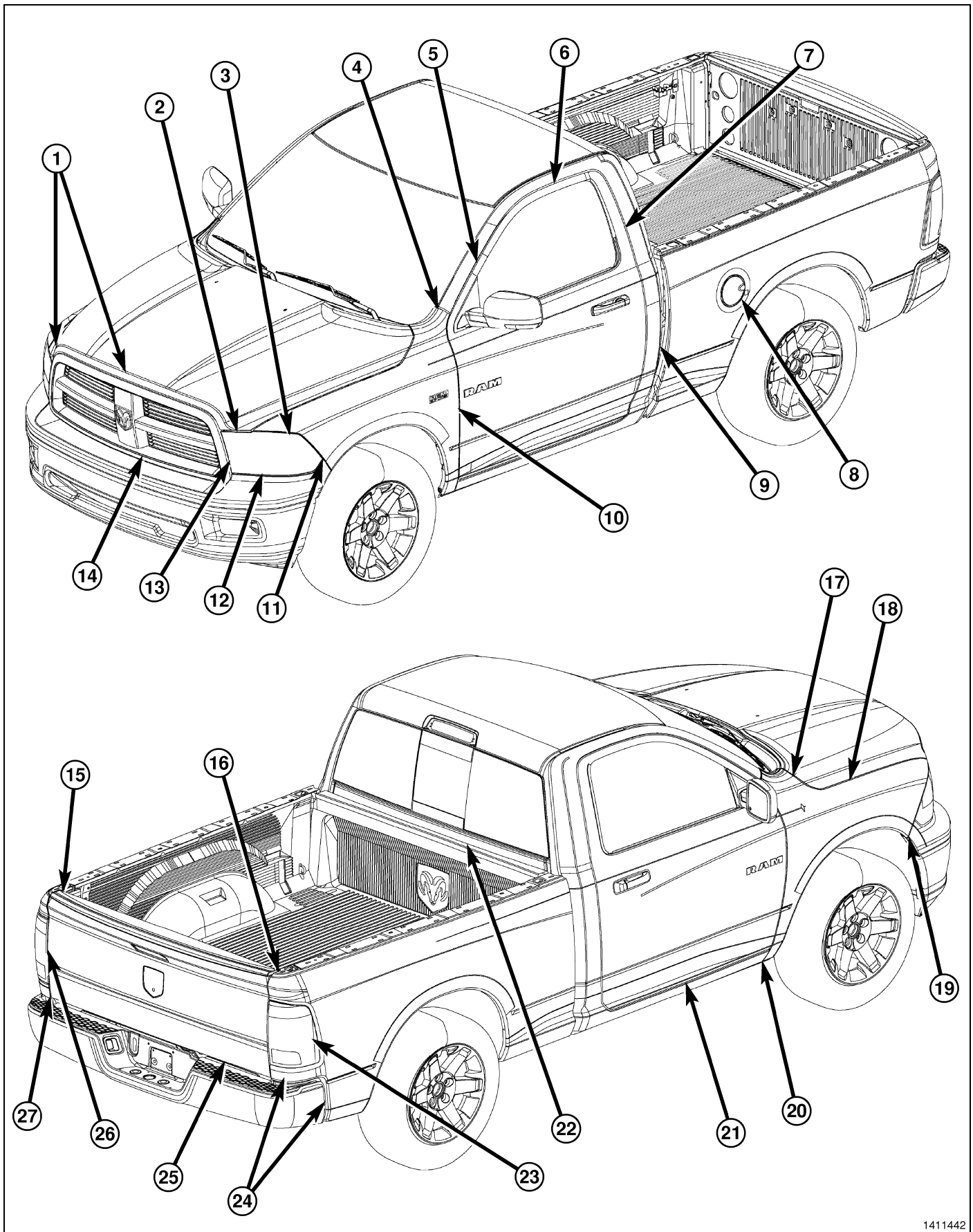

Fig. 16 140.5 In. Wheelbase – Crew Cab – 5.7 Ft. Box

454952

GAP AND FLUSH DIMENSIONS**GAP AND FLUSH DIMENSIONS INDEX**

DESCRIPTION	FIGURE
REGULAR CAB	(Fig. 17)
QUAD CAB	(Fig. 18)
CREW CAB	(Fig. 19)



1411442

Fig. 17 REGULAR CAB

NOTE: All measurements are in millimeters.			
O/F = Over Flush		U/F = Under Flush	
U/D = Up/Down		F/A = Fore/Aft	
DIMENSION	DESCRIPTION	GAP	FLUSH
1	Hood to grille (along top)	7.0 +/- 2.0 transition to 4.5 after corner	Hood O/F 7.0 @ center to 5.5 @ corner to 1.0 around corner +/- 2.0
2	Headlamp to hood	7.0 +/- 2.0 Parallel within 2.0 Side to side within 3.0	Headlamp O/F 4.0 +/- 2.0 Parallel within 2.0 Side to side within 2.0
3	Fender to headlamp	2.5 +/- 2.0 Parallel within 2.0 Side to side within 3.0	Fender O/F 2.0 +/- 2.0 Parallel within 2.0 Side to side within 3.0
4	Fender to a-pillar	3.0 +/- 1.5 Parallel within 1.5 Side to side within 2.0	Fender O/F 0.75 +/- 1.5 Parallel within 1.5 Side to side within 2.0
5	Aperture to front door @ a-pillar	4.5 +/- 1.5 Parallel within 1.5 Front to back within 1.5	Aperture O/F 1.5 +/- 1.5 Parallel within 1.5 Front to back within 1.5
6	Aperture to front door @ roof	4.5 +/- 1.5 Parallel within 1.5 Front to back within 1.5	Aperture O/F 1.5 +/- 1.5 Parallel within 1.5 Front to back within 1.5
7	Aperture to rear door @ roof	4.5 +/- 1.5 Parallel within 1.5 Front to back within 1.5	Aperture O/F 1.5 +/- 1.5 Parallel within 1.5
8	Box outer to fuel filler door	4.5 +/- 1.5 Parallel within 1.5	0.0 +/- 1.5 Parallel within 1.5
9	Cab to box	35.0 +/- 4.0 Parallel within 3.0	Cab O/F 6.0 +/- 4.0 Parallel within 3.0
10	Fender to front door	4.5 +/- 1.5 Parallel within 1.5 Top to bottom within 1.5	Box outer O/F 0.5 +/- 1.5 Parallel within 1.5 Top to bottom within 1.5
11	Fascia to fender	Net to 2.0 Parallel within 2.0	0.0 +/- 2.0 Parallel within 2.0
12	Headlamp to fascia	4.5 +/- 2.0 Parallel within 2.0 Side to side within 3.0	0.0 +/- 2.0 Parallel within 2.0 Side to side within 2.0
13	Grille to headlamp	3.7 +/- 2.0 Parallel within 2.0 Side to side within 3.0	—
14	Grille to fascia	3.5 +/- 2.0	—

NOTE: All measurements are in millimeters.			
O/F = Over Flush		U/F = Under Flush	
U/D = Up/Down		F/A = Fore/Aft	
DIMENSION	DESCRIPTION	GAP	FLUSH
		Parallel within 2.0 Side to side within 2.0	
15	Deflector to tailgate inner	F/A 0.0 +2.0/- 0.0 Parallel within 2.0	—
16	Box cab to tailgate deflector	—	U/D 0.0 +/- 2.0
17	Fender to hood @ cowl	4.5 +/- 1.5 Parallel within 1.5 Side to side within 2.0	Fender U/D-U/F 0.75 +/-1.5 Cross/car 0.0 +/- 1.5
18	Fender to hood	4.5 +/- 1.5 Parallel within 1.5 Side to side within 2.0	Fender O/F 0.5 +/- 1.5
19	Wheel flare to fascia	1.0 +2.0/- 1.0 Parallel within 2.0	0.0 +/- 2.0 Parallel within 2.0
20	Fender to sill	4.5 +/- 1.5 Parallel within 1.5 Side to side within 2.0	Fender O/F 1.0 +/- 1.5
21	Sill to front door	6.0 +/- 1.5 Parallel within 1.5 Front to back within 1.5	Sill O/F 4.5 +/- 1.5 Parallel within 1.5 Front to back within 1.5
22	Cab to box	32.0 +/- 3.5 Parallel within 3.0	—
23	Box outer to tail lamp	2.5 +/- 2.0 Parallel within 2.0	0.0 +/- 2.0
24	Rear bumper to box outer	F/A 30.4 +/- 5.0 Parallel within 5.0 U/D 26.0 +/- 3.0 Parallel within 4.0	+/- 1.5 Parallel within 1.5
25	Bumper to tailgate	33.4 +/- 3.0 Parallel within 4.0	—
26	Tail lamp to tailgate	5.0 +/- 2.0 Parallel within 2.0 Side to side within 2.0	Tail lamp O/F 1.5 +/- 2.0
27	Box outer to tailgate	5.0 +/- 1.5 Parallel within 1.5 Side to side within 1.5	Box outer O/F 1.5 +/- 1.5 Parallel within 1.5 Side to side within 1.5

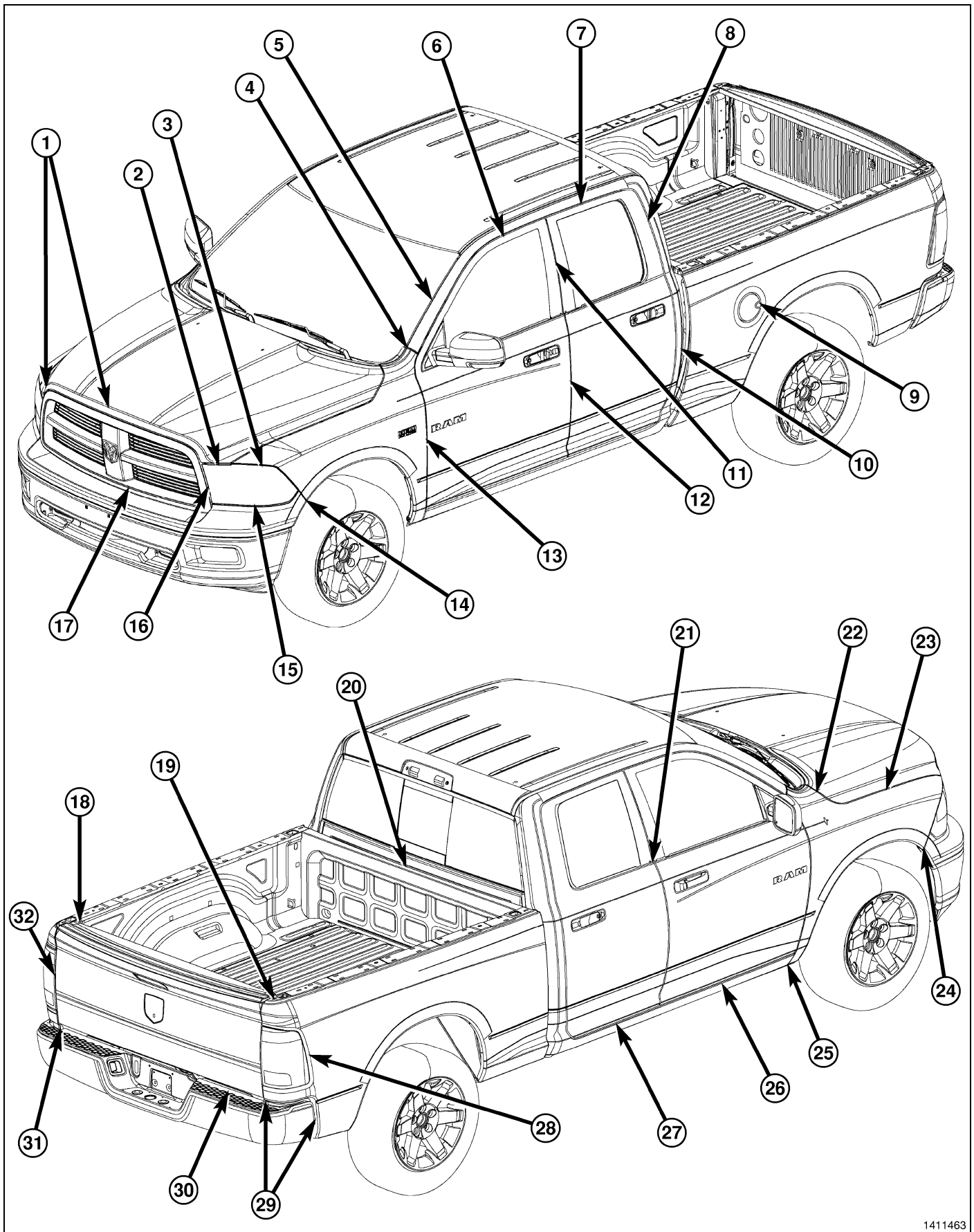

1411463

Fig. 18 QUAD CAB

NOTE: All measurements are in millimeters.			
O/F = Over Flush		U/D = Up/Down	
U/F = Under Flush		F/A = Fore/Aft	
DIMENSION	DESCRIPTION	GAP	FLUSH
1	Hood to grille (along top)	7.0 +/- 2.0 transition to 4.5 after corner	Hood O/F 7.0 @ center to 5.5 @ corner to 1.0 around corner +/- 2.0
2	Headlamp to hood	7.0 +/- 2.0 Parallel within 2.0 Side to side within 3.0	Headlamp O/F 4.0 +/- 2.0 Parallel within 2.0 Side to side within 2.0
3	Fender to headlamp	2.5 +/- 2.0 Parallel within 2.0 Side to side within 3.0	Fender O/F 2.0 +/- 2.0 Parallel within 2.0 Side to side within 3.0
4	Fender to a-pillar	3.0 +/- 1.5 Parallel within 1.5 Side to side within 2.0	Fender O/F 0.75 +/- 1.5 Parallel within 1.5 Side to side within 2.0
5	Aperture to front door @ a-pillar	4.5 +/- 1.5 Parallel within 1.5 Front to back within 1.5	Aperture O/F 1.5 +/- 1.5 Parallel within 1.5 Front to back within 1.5
6	Aperture to front door @ roof	4.5 +/- 1.5 Parallel within 1.5 Front to back within 1.5	Aperture O/F 1.5 +/- 1.5 Parallel within 1.5 Front to back within 1.5
7	Aperture to rear door @ roof	4.5 +/- 1.5 Parallel within 1.5 Front to back within 1.5	Aperture O/F 1.5 +/- 1.5 Parallel within 1.5
8	Quarter panel to rear door	4.5 +/- 1.5 Parallel within 1.5 Top to bottom within 1.5	0.0 +/- 1.5 Parallel within 1.5
9	Box outer to fuel filler door	4.5 +/- 1.5 Parallel within 1.5	Box outer O/F 0.5 +/- 1.5 Parallel within 1.5
10	Cab to box	35.0 +/- 4.0 Parallel within 3.0	Cab O/F 6.0 +/- 4.0 Parallel within 3.0
11	Front door to rear door above belt	4.5 +/- 1.5 Parallel within 1.5 Top to bottom within 1.5	0.0 +/- 1.5 Parallel within 1.5
12	Front door to rear door below belt	4.5 +/- 1.5 Parallel within 1.5 Top to bottom within 1.5	Front door O/F 1.0 Between belt and character line +/- 1.5 Parallel within 1.5 1.0 to 0.0 below character line +/- 1.5

NOTE: All measurements are in millimeters.			
O/F = Over Flush		U/D = Up/Down	
U/F = Under Flush		F/A = Fore/Aft	
DIMENSION	DESCRIPTION	GAP	FLUSH
13	Fender to front door	4.5 +/- 1.5 Parallel within 1.5 Top to bottom within 1.5	Fender O/F 1.0 +/- 1.5 Parallel within 1.5 Top to bottom within 1.5
14	Fascia to fender	Net to 2.0 Parallel within 2.0	0.0 +/- 2.0 Parallel within 2.0
15	Headlamp to fascia	4.5 +/- 2.0 Parallel within 2.0 Side to side within 3.0	0.0 +/- 2.0 Parallel within 2.0 Side to side within 2.0
16	Grille to headlamp	3.7 +/- 2.0 Parallel within 2.0 Side to side within 3.0	—
17	Grille to fascia	3.5 +/- 2.0 Parallel within 2.0 Side to side within 2.0	—
18	Deflector to tailgate inner	F/A 0.0 +2.0/- 0.0 Parallel within 2.0	—
19	Box cab to tailgate deflector	—	U/D 0.0 +/- 2.0
20	Cab to box	32.0 +/- 3.5 Parallel within 3.0	—
21	Front door belt to rear door belt	U/D alignment: 0 +/- 2.0	—
22	Fender to hood @ cowl	4.5 +/- 1.5 Parallel within 1.5 Side to side within 2.0	Fender U/D-U/F 0.75 +/-1.5 Cross/car 0.0 +/- 1.5
23	Fender to hood	4.5 +/- 1.5 Parallel within 1.5 Side to side within 2.0	Fender O/F 0.5 +/- 1.5
24	Wheel flare to fascia	1.0 +2.0/- 1.0 Parallel within 2.0	0.0 +/- 2.0 Parallel within 2.0
25	Fender to sill	4.5 +/- 1.5 Parallel within 1.5 Side to side within 2.0	Fender O/F 1.0 +/- 1.5
26	Sill to front door	6.0 +/- 1.5 Parallel within 1.5 Front to back within 1.5	Sill O/F 4.5 +/- 1.5 Parallel within 1.5 Front to back within 1.5
27	Sill to rear door	6.0 +/- 1.5 Parallel within 1.5	Sill O/F 4.5 +/- 1.5 Parallel within 1.5

NOTE: All measurements are in millimeters.			
O/F = Over Flush		U/D = Up/Down	
U/F = Under Flush		F/A = Fore/Aft	
DIMENSION	DESCRIPTION	GAP	FLUSH
		Front to back within 1.5	Front to back within 1.5
28	Box outer to tail lamp	2.5 +/- 2.0 Parallel within 2.0	0.0 +/- 2.0
29	Rear bumper to box outer	F/A 30.4 +/- 5.0 Parallel within 5.0 U/D 26.0 +/- 3.0 Parallel within 4.0	+/- 1.5 Parallel within 1.5
30	Bumper to tailgate	33.4 +/- 3.0 Parallel within 4.0	—
31	Box outer to tailgate	5.0 +/- 1.5 Parallel within 1.5 Side to side within 1.5	Box outer O/F 1.5 +/- 1.5 Parallel within 1.5 Side to side within 1.5
32	Tail lamp to tailgate	5.0 +/- 2.0 Parallel within 2.0 Side to side within 2.0	Tail lamp O/F 1.5 +/- 2.0

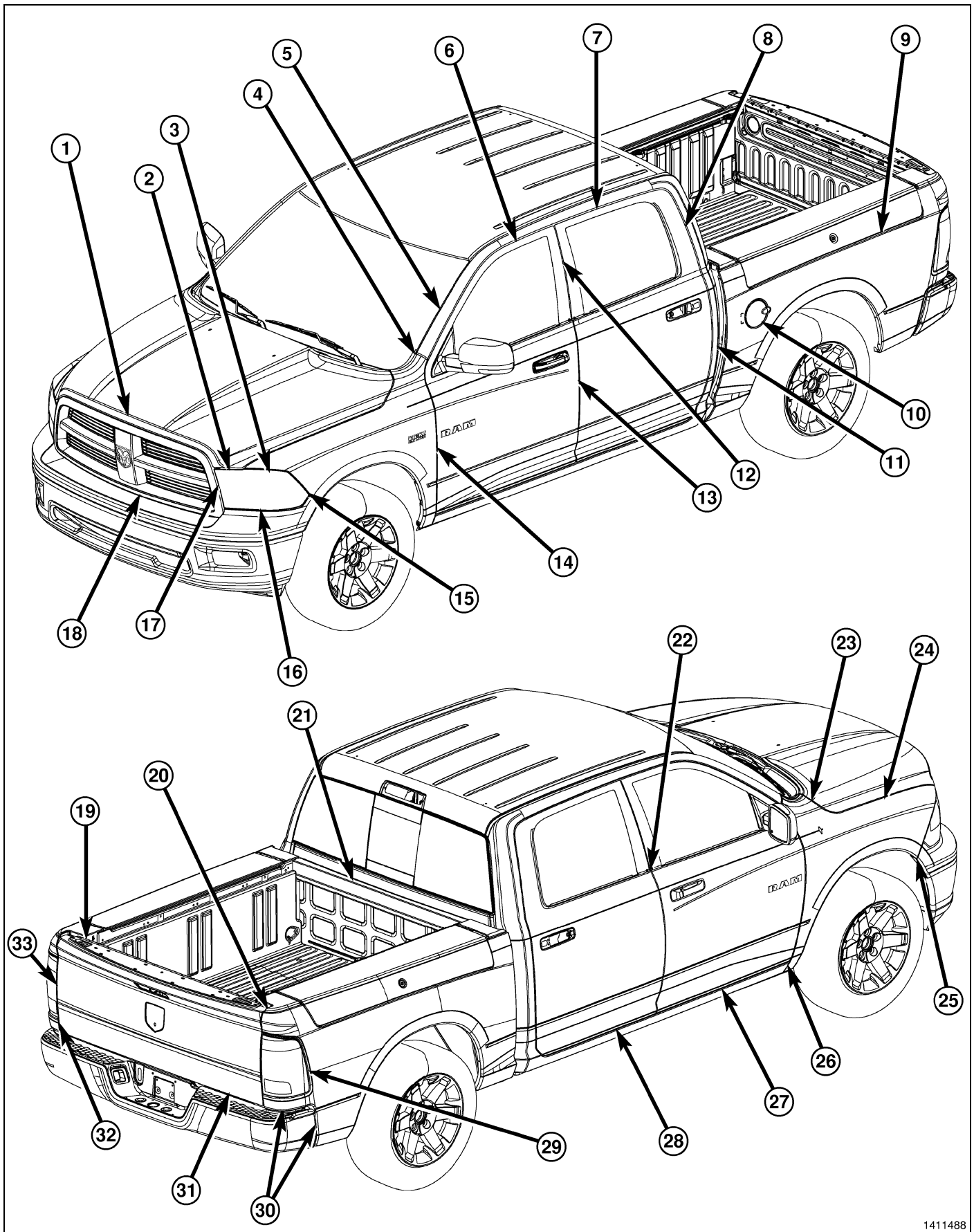

1411488

Fig. 19 CREW CAB

NOTE: All measurements are in millimeters.			
O/F = Over Flush		U/D = Up/Down	
U/F = Under Flush		F/A = Fore/Aft	
DIMENSION	DESCRIPTION	GAP	FLUSH
1	Hood to grille (along top)	7.0 +/- 2.0 transition to 4.5 after corner	Hood O/F 7.0 @ center to 5.5 @ corner to 1.0 around corner +/- 2.0
2	Headlamp to hood	7.0 +/- 2.0 Parallel within 2.0 Side to side within 3.0	Headlamp O/F 4.0 +/- 2.0 Parallel within 2.0 Side to side within 2.0
3	Fender to headlamp	2.5 +/- 2.0 Parallel within 2.0 Side to side within 3.0	Fender O/F 2.0 +/- 2.0 Parallel within 2.0 Side to side within 3.0
4	Fender to a-pillar	3.0 +/- 1.5 Parallel within 1.5 Side to side within 2.0	Fender O/F 0.75 +/- 1.5 Parallel within 1.5 Side to side within 2.0
5	Aperture to front door @ a-pillar	4.5 +/- 1.5 Parallel within 1.5 Front to back within 1.5	Aperture O/F 1.5 +/- 1.5 Parallel within 1.5 Front to back within 1.5
6	Aperture to front door @ roof	4.5 +/- 1.5 Parallel within 1.5 Front to back within 1.5	Aperture O/F 1.5 +/- 1.5 Parallel within 1.5 Front to back within 1.5
7	Aperture to rear door @ roof	4.5 +/- 1.5 Parallel within 1.5 Front to back within 1.5	Aperture O/F 1.5 +/- 1.5 Parallel within 1.5
8	Quarter panel to rear door	4.5 +/- 1.5 Parallel within 1.5 Top to bottom within 1.5	0.0 +/- 1.5 Parallel within 1.5
9	Ram box to box outer	5.0 +/- 2.0	Flush +/- 2.0
10	Box outer to fuel filler door	4.5 +/- 1.5 Parallel within 1.5	Box Outer O/F 0.5 +/- 1.5 Parallel within 1.5
11	Cab to box	35.0 +/- 4.0 Parallel within 3.0	Cab O/F 6.0 +/- 4.0 Parallel within 3.0
12	Front door to rear door above belt	4.5 +/- 1.5 Parallel within 1.5 Top to bottom within 1.5	0.0 +/- 1.5 Parallel within 1.5
13	Front door to rear door below belt	4.5 +/- 1.5 Parallel within 1.5 Top to bottom within 1.5	Front Door O/F 1.0 Between belt and Character line +/- 1.5 Parallel within 1.5 1.0 to 0.0 below Character line +/- 1.5

NOTE: All measurements are in millimeters.			
O/F = Over Flush		U/D = Up/Down	
U/F = Under Flush		F/A = Fore/Aft	
DIMENSION	DESCRIPTION	GAP	FLUSH
14	Fender to front door	4.5 +/- 1.5 Parallel within 1.5 Top to bottom within 1.5	Fender O/F 1.0 +/- 1.5 Parallel within 1.5 Top to bottom within 1.5
15	Fascia to fender	Net to 2.0 Parallel within 2.0	0.0 +/- 2.0 Parallel within 2.0
16	Headlamp to fascia	4.5 +/- 2.0 Parallel within 2.0 Side to side within 3.0	0.0 +/- 2.0 Parallel within 2.0 Side to side within 2.0
17	Grille to headlamp	3.7 +/- 2.0 Parallel within 2.0 Side to side within 3.0	—
18	Grille to fascia	3.5 +/- 2.0 Parallel within 2.0 Side to side within 2.0	—
19	Deflector to tailgate inner	F/A 0.0 +2.0/- 0.0 Parallel within 2.0	—
20	Box cab to tailgate deflector	—	U/D 0.0 +/- 2.0
21	Cab to box	32.0 +/- 3.5 Parallel within 3.0	—
22	Front door belt to rear door belt	U/D Alignment: 0 +/- 2.0	—
23	Fender to hood @ cowl	4.5 +/- 1.5 Parallel within 1.5 Side to side within 2.0	Fender U/D-U/F 0.75 +/- 1.5 Cross/Car 0.0 +/- 1.5
24	Fender to hood	4.5 +/- 1.5 Parallel within 1.5 Side to side within 2.0	Fender O/F 0.5 +/- 1.5
25	Wheel flare to fascia	1.0 +2.0/- 1.0 Parallel within 2.0	0.0 +/- 2.0 Parallel within 2.0
26	Fender to sill	4.5 +/- 1.5 Parallel within 1.5 Side to side within 2.0	Fender O/F 1.0 +/- 1.5
27	Sill to front door	6.0 +/- 1.5 Parallel within 1.5 Front to back within 1.5	Sill O/F 4.5 +/- 1.5 Parallel within 1.5 Front to back within 1.5

NOTE: All measurements are in millimeters.			
O/F = Over Flush		U/D = Up/Down	
U/F = Under Flush		F/A = Fore/Aft	
DIMENSION	DESCRIPTION	GAP	FLUSH
28	Sill to rear door	6.0 +/- 1.5 Parallel within 1.5 Front to back within 1.5	Sill O/F 4.5 +/- 1.5 Parallel within 1.5 Front to back within 1.5
29	Box outer to tail lamp	2.5 +/- 2.0 Parallel within 2.0	0.0 +/- 2.0
30	Rear bumper to box outer	F/A 30.4 +/- 5.0 Parallel within 5.0 U/D 26.0 +/- 3.0 Parallel within 4.0	+/- 1.5 Parallel within 1.5
31	Bumper to tailgate	33.4 +/- 3.0 Parallel within 4.0	—
32	Box outer to tailgate	5.0 +/- 1.5 Parallel within 1.5 Side to side within 1.5	Box Outer O/F 1.5 +/- 1.5 Parallel within 1.5 Side to side within 1.5
33	Tail lamp to tailgate	5.0 +/- 2.0 Parallel within 2.0 Side to side within 2.0	Tail Lamp O/F 1.5 +/- 2.0

PAINT CODES

NOTE: Because of late model changes to the available paint colors Refer to 00 - Vehicle Data/Vehicle Information/Vehicle Certification Label - Description.

EXTERIOR COLORS

EXTERIOR COLOR	CHRYSLER CODE
Austin Tan Pearlcoat	FKL
Blazing Saddle Pearlcoat	JUS
Bright Silver Metallic Clearcoat	WS2
Bright White Clearcoat	GW7
Brilliant Black Crystal Pearlcoat	AXR
Deep Cherry Pearlcoat	JRP
Deep Water Blue Pearlcoat	GBS
Flame Red Clearcoat	PR4
Hunter Green	JGX
Inferno Red Pearlcoat	ARH/ARJ
Light Greystone Pearlcoat	EDA
Mango Tango Pearlcoat	HVG
Mineral Grey Metallic Clearcoat	CDM

EXTERIOR COLORS, continued

EXTERIOR COLOR	CHRYSLER CODE
Rugged Brown Pearlcoat	GTW
Sagebrush Pearlcoat	JGX
Stone White Clearcoat	SW1
Torred Clearcoat	ZR3
White Gold Metallic Clearcoat	HWL

INTERIOR COLORS

INTERIOR COLOR	CHRYSLER CODE
Dark Slate Gray	DV
Dark Slate Gray/Medium Greystone	V3
Dark Slate Gray/Russet	DE
Light Pebble Beige/Bark Brown	KT

VEHICLE CERTIFICATION LABEL

A vehicle certification label is attached to every Chrysler Group LLC vehicle. The label certifies that the vehicle conforms to all applicable Federal Motor Vehicle Standards. The label also lists:

- Month and year of vehicle manufacture.
- Gross Vehicle Weight Rating (GVWR). The gross front and rear axle weight ratings (GAWR's) are based on a minimum rim size and maximum cold tire inflation pressure.
- Vehicle Identification Number (VIN).
- Type of vehicle.
- Type of rear wheels.
- Bar code.
- Month, Day and Hour (MDH) of final assembly.
- Paint and Trim codes.
- Country of origin.

The label is located on the driver-side door shut-face.

MFD BY CHRYSLER LLC	DATE OF MFR 11-07	GVWR 2745 KG(06050 LB)
GAWR FRONT 1339 KG(2950 LB)	WITH TIRES P225/65R17	RIMS AT 17X6.5
GAWR REAR 1407 KG(3100 LB)	WITH TIRES P225/65R17	RIMS AT 17X6.5
COLD 250 KPA(36 PSI)		
COLD 250 KPA(36 PSI)		
THIS VEHICLE CONFORMS TO ALL APPLICABLE U.S.A. FEDERAL MOTOR VEHICLE SAFETY STANDARDS IN EFFECT ON THE DATE OF MANUFACTURE SHOWN ABOVE.		
VIN: 2A8HR64X68R148067	TYPE: MPV	SINGLE X DUAL
		
MDH: 112707 016AB	PNT:PKG	VEHICLE MADE IN CANADA TRM:TLT1 464B505

19125

Vehicle Certification Label - Typical**Standard Procedure****SERVICE AFTER A SUPPLEMENTAL RESTRAINT DEPLOYMENT**

Any vehicle which is to be returned to use following a Supplemental Restraint System (SRS) component deployment must have the deployed restraints replaced. In addition, the following guidelines MUST be observed.

- **Following ANY major vehicle impact damage in the vicinity of an impact sensor or the ORC** - It is critical that the mounting surfaces and mounting brackets for the Occupant Restraint Controller (ORC), front impact sensors and side impact sensors located within the proximity of the impact damage be closely inspected and restored to their original conditions. Because the ORC and each impact sensor are used by the SRS to monitor or confirm the direction and severity of a vehicle impact, improper orientation or insecure fastening of these components may cause airbags not to deploy when required, or to deploy when not required.

- **If an active head restraint is deployed** - Deployed Active Head Restraint (AHR) units that are undamaged are designed with the intention of reuse. However, the deployed AHR units must be properly reset following deployment. (Refer to Service Manual Section 10 - Restraints/RESTRAINT, Active Head - Standard Procedure)
- **If the driver airbag is deployed** - If the driver airbag has been deployed, the Steering Column Control Module (SCCM) with integral clockspring and the steering column assembly must also be replaced.
- **If the knee blocker airbag is deployed** - On vehicles so equipped, if the knee blocker airbag (also known as the Knee AirBag/KAB or Inflatable Knee Blocker/IKB) has been deployed, the entire instrument panel assembly must also be replaced.
- **If the passenger airbag is deployed** - If the passenger airbag has been deployed, the instrument panel top cover must also be replaced.
- **If a seat airbag is deployed** - If a seat (pelvic and thorax) airbag has been deployed, the seat back frame, the seat back foam and the seat back trim cover on the same side of the vehicle as the deployed airbag must also be replaced.
- **If a seat belt tensioner is deployed** - The seat belt tensioners are deployed in conjunction with the front airbags, but can also be deployed with seat (pelvic and thorax) or side curtain airbags. The seat belt tensioners must be replaced if either front airbag has been deployed, and must be inspected if either seat or side curtain airbag has been deployed.
- **If a side curtain airbag is deployed** - If a side curtain airbag has been deployed, the headliner as well as the upper A, B and C-pillar trim on the same side of the vehicle as the deployed airbag must also be replaced. On vehicles with an optional sunroof, the sunroof drain tubes and hoses must be closely inspected following a side curtain airbag deployment.

The components identified with the deployed SRS components in the preceding list are not intended for reuse and will be damaged or weakened as a result of an airbag deployment, which may or may not be obvious during a visual inspection. All other vehicle components should be closely inspected following any SRS component deployment, but are to be replaced only as required by the extent of the visible damage incurred.

SQUIB CIRCUIT WIRING REPAIRS

In addition to the preceding guidelines, be aware that the heat created by the initiator during an airbag or tensioner deployment will cause collateral damage to the connected wiring (squib circuits) and connector insulators. There are two methods by which an airbag or seat belt tensioner may be connected to the vehicle electrical system. The first method involves a short pigtail harness and connector insulator that are integral to the airbag or tensioner unit and are replaced as a unit with the service replacement airbag or seat belt tensioner. This connection method typically requires no additional wiring repair following a deployment.

However, the second connection method involves a wire harness takeout and connector insulator that are connected directly to the airbag or tensioner initiator or squib. These direct-connect type take outs and connector insulators **MUST** be repaired following an airbag or seat belt tensioner deployment using the approved Supplemental Restraint System Wiring Repairs procedure. (Refer to Service Manual Section 10 - Restraints - Standard Procedure).

AIRBAG SQUIB STATUS

Multistage airbags with multiple initiators (squibs) must be checked to determine that all squibs were used during the deployment event. The driver and passenger airbags in this vehicle are deployed by electrical signals generated by the Occupant Restraint Controller (ORC) through the driver or passenger squib 1 and squib 2 circuits to the two initiators in the airbag inflators. Typically, both initiators are used and all potentially hazardous chemicals are burned during an airbag deployment event. However, it is possible for only one initiator to be used; therefore, it is always necessary to confirm that both initiators have been used in order to avoid the improper handling or disposal of potentially live pyrotechnic or hazardous materials. The following procedure should be performed using a diagnostic scan tool to verify the status of both airbag squibs before either deployed airbag is removed from the vehicle for disposal.

CAUTION: Deployed front airbags having two initiators (squibs) in the airbag inflator may or may not have live pyrotechnic material within the inflator. Do not dispose of these airbags unless you are certain of complete deployment. Refer to the Hazardous Substance Control System for information regarding the potentially hazardous properties of the subject component and the proper safe handling procedures. Then dispose of all non-deployed and deployed airbags and seat belt tensioners in a manner consistent with state, provincial, local and federal regulations.

1. Be certain that the diagnostic scan tool contains the latest version of the proper diagnostic software. Connect the scan tool to the 16-way Data Link Connector (DLC). The DLC is located on the driver side lower edge of the instrument panel, outboard of the steering column.
2. Turn the ignition switch to the ON position.
3. Using the scan tool, read and record the active (current) Diagnostic Trouble Code (DTC) data.

Using the active DTC information, refer to the **Airbag Squib Status** table to determine the status of both driver and passenger airbag squibs.

AIRBAG SQUIB STATUS		
IF THE ACTIVE DTC IS:	CONDITIONS	SQUIB STATUS
Driver or Passenger Squib 1 open	AND the stored DTC minutes for both Driver or Passenger squibs are within 15 minutes of each other	Both Squib 1 and 2 were used.
Driver or Passenger Squib 2 open		
Driver or Passenger Squib 1 open	AND the stored DTC minutes for Driver or Passenger Squib 2 open is GREATER than the stored DTC minutes for Driver or Passenger Squib 1 by 15 minutes or more	Squib 1 was used; Squib 2 is live.
Driver or Passenger Squib 2 open		
Driver or Passenger Squib 1 open	AND the stored DTC minutes for Driver or Passenger Squib 1 open is GREATER than the stored DTC minutes for Driver or Passenger Squib 2 by 15 minutes or more	Squib 1 is live; Squib 2 was used.
Driver or Passenger Squib 2 open		
Driver or Passenger Squib 1 open	AND Driver or Passenger Squib 2 open is NOT an active code	Squib 1 was used; Squib 2 is live.
Driver or Passenger Squib 2 open	AND Driver or Passenger Squib 1 open is NOT an active code	Squib 1 is live; Squib 2 was used.

NOTE: If none of the Driver or Passenger Squib 1 or 2 open are active codes, the status of the airbag squibs is unknown. In this case the airbag should be handled and disposed of as if the squibs were both live.

CLEANUP PROCEDURE

Following a Supplemental Restraint System (SRS) component deployment, the vehicle interior will contain a powdery residue. This residue consists primarily of harmless particulate by-products of the small pyrotechnic charge that initiates the propellant used to deploy a SRS component. However, this residue may also contain traces of sodium hydroxide powder, a chemical by-product of the propellant material that is used to generate the inert gas that inflates the airbag. Since sodium hydroxide powder can irritate the skin, eyes, nose, or throat, be certain to wear safety glasses, rubber gloves, and a long-sleeved shirt during cleanup.

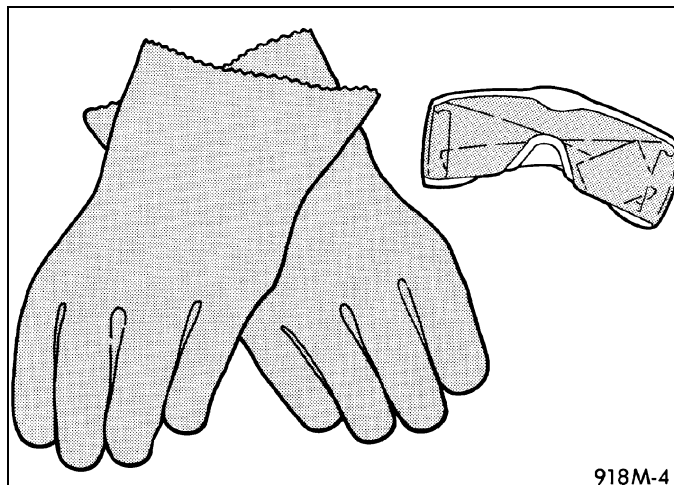

918M-4

WARNING: To avoid serious or fatal injury, if you experience skin irritation during cleanup, run cool water over the affected area. Also, if you experience irritation of the nose or throat, exit the vehicle for fresh air until the irritation ceases. If irritation continues, see a physician.

1. Begin the cleanup by using a vacuum cleaner to remove any residual powder from the vehicle interior. Clean from outside the vehicle and work your way inside, so that you avoid kneeling or sitting on a non-cleaned area.
2. Be certain to vacuum the heater and air conditioning outlets as well. Run the heater and air conditioner blower on the lowest speed setting and vacuum any powder expelled from the outlets.

CAUTION: Deployed front airbags having two initiators (squibs) in the airbag inflator may or may not have live pyrotechnic material within the inflator. Do not dispose of these airbags unless you are certain of complete deployment. Refer to the AIRBAG SQUIB STATUS heading within this information. All damaged, ineffective, or non-deployed Supplemental Restraint System (SRS) components which are replaced on vehicles are to be handled and disposed of properly. If an airbag or seat belt tensioner unit is ineffective or damaged and non-deployed, refer to the Hazardous Substance Control System for information regarding the potentially hazardous properties of the subject component and the proper safe handling procedures. Then dispose of all non-deployed and deployed airbags and seat belt tensioners in a manner consistent with state, provincial, local and federal regulations.

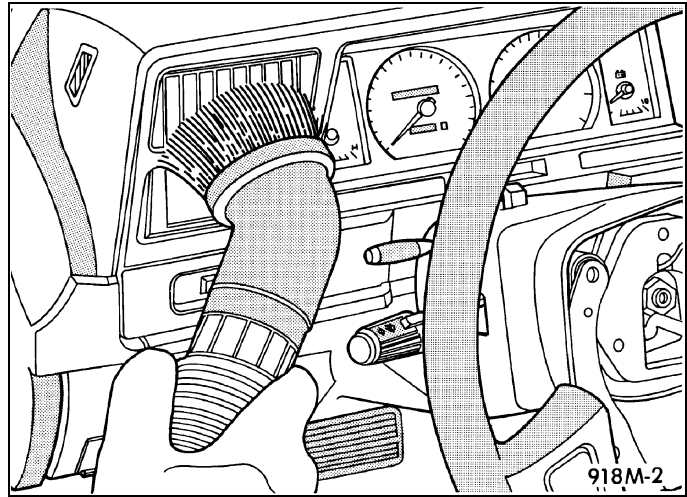

3. Next, remove the deployed SRS components from the vehicle. Refer to the appropriate service removal procedures.
4. You may need to vacuum the interior of the vehicle a second time to recover all of the powder.

BASECOAT/CLEARCOAT FINISH

The original equipment paint finish is a multi step process that involves cleaning, applying electro de-position (E-coat), anti-chip primer, basecoat, and clearcoat steps.

CAUTION: Do not use abrasive chemicals, abrasive compounds or harsh alkaline based cleaning solvents on the painted surfaces of a vehicle. Failure to follow this caution can result in damage to vehicle finish.

On most vehicles a two-part paint application (basecoat/clearcoat) is used. Color paint that is applied to primer is called basecoat. A clear coat paint is then applied to protect the basecoat from ultraviolet light and to provide a durable high-gloss finish.

FINESSE SANDING, BUFFING, AND POLISHING

CAUTION: Do not remove more than 0.5 mils of clearcoat finish when sanding, hand buffing or polishing. Basecoat paint must retain clearcoat for durability.

CAUTION: If the finish has been finesse sanded in the past, it cannot be repeated. Failure to follow this caution can result in damage to vehicle finish.

NOTE: Finesse sanding should only be performed by a trained automotive paint technician.

Minor acid etching, orange peel, or smudging in a clearcoat or single-stage finish can be reduced with light finesse sanding, hand buffing and polishing. Use a Paint Thickness Gauge #PR-ETG-2X or equivalent to determine clearcoat or single-stage paint thickness before and after the repair.

PAINT TOUCH-UP

If the painted metal surface of a vehicle becomes scratched or chipped, it should be touched-up as soon as possible to avoid corrosion.

WARNING: Use an OSHA approved respirator and safety glasses when spraying paint or solvents. Failure to follow this warning may result in possible personal injury or death.

When repairing painted metal surfaces, for best results, use MOPAR® Scratch Filler/Primer, Touch-Up Paints and Clear Top Coat.

1. Scrape any loose paint and corrosion from inside the scratch or chip.

WARNING: Avoid prolonged skin contact with petroleum or alcohol-based cleaning solvents. Failure to follow this warning can result in possible personal injury or death.

2. Clean affected area with MOPAR® Tar/Road Oil Remover or equivalent, and allow to dry.
3. Fill the inside of the scratch or chip with a coat of filler/primer. Do not overlap primer onto good surface finish. The applicator brush should be wet enough to puddle-fill the scratch or chip without running. Do not stroke brush applicator on body surface. Allow the filler/primer to dry hard.
4. Cover the filler/primer with color touch-up paint. Do not overlap touch-up color onto the original color coat around the scratch or chip. Butt the new color to the original color, if possible. Do not stroke applicator brush on body surface. Allow touch-up paint to dry hard.
5. On vehicles with clearcoat, apply clear top coat to touch-up paint with the same technique as described in Step #4. Allow clear top coat to dry hard. If desired, the clearcoat can be lightly finesse sanded (1500 grit) and polished with rubbing compound.

BED LINER REPAIR

Dual Cartridge Gun Repair

WARNING: Avoid prolonged skin contact with resin, petroleum, or alcohol based solvents. Personal injury can result.

WARNING: Failure to follow these instructions may result in serious or fatal injury.

Dual cartridge repair will require use of dispenser and materials readily available through Ultimate Linings Ltd..

- Dual cartridge caulk gun
- Quick Fix Kit (dual cartridge repair material)
- Texture pad
- Bedliner Conditioner

All other tools and materials should be readily available shop supplies.

NOTE: When repairing an area more than 30cm. (12 in.) long it is best to do in shorter sections.

1. Carefully cut around the tear or gouge and remove the loose material with a flat bladed tool.
2. Use prep solvent to clean the effected area.
3. Mask off tightly to the repair area.

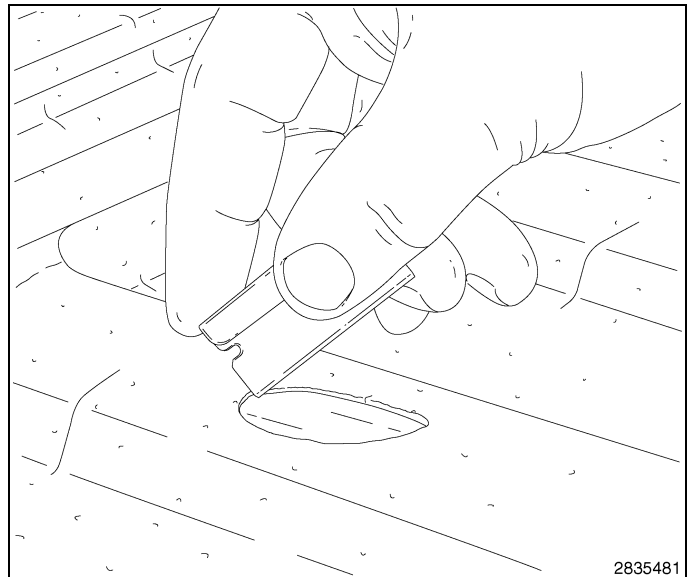

4. Install mixing tip on cartridge and purge 2.5cm. (1in.) of repair material . This will allow proper mix.
5. Fill area slightly higher than the bed liner height. Do not overfill.
6. Carefully remove masking tape.
7. Apply mold release or similar product to texture pad.

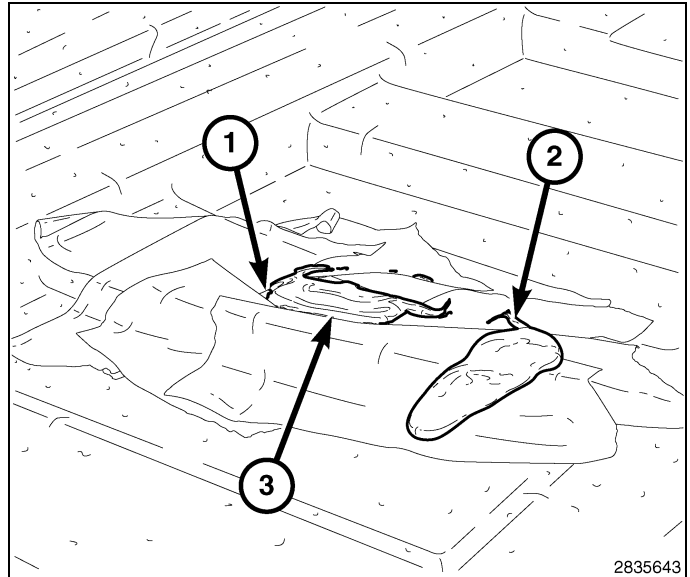

NOTE: Wait 7-8 minutes for material to partially set before proceeding to next step. If repair material is sticking to texture pad more time is needed. (Fig. 20)

NOTE: For best results do not try to spread out the material all at once. Steps 8-11 may need to be repeated several times.

8. Apply firm and even pressure for 30 seconds. This will force repair material out to the sides of repair area.
9. Release the pressure and let the pad set in place for 30 seconds .
10. Re-apply pressure for 30 seconds, then remove the pad.
11. Use the edge of the texture pad to feather out the edges of the repair.
12. When the repair is complete, wait 10 minutes then apply bedliner conditioner to the area.

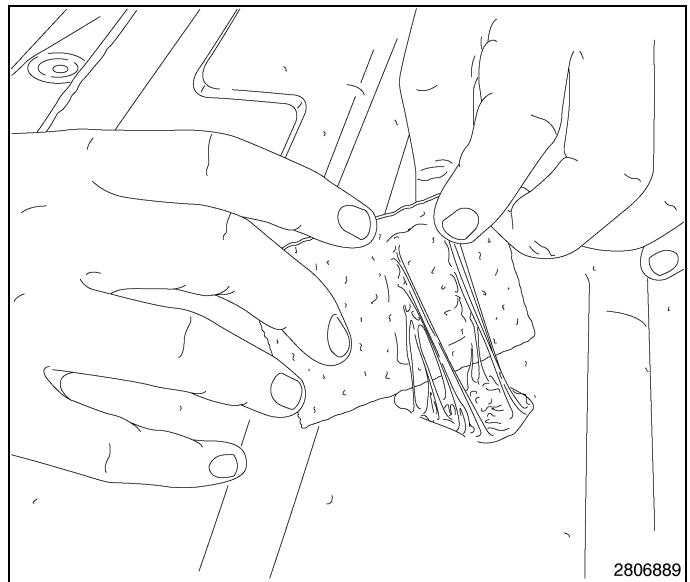

Fig. 20

Spray On Repair

WARNING:

- Eye protection should be used when servicing components. Personal injury can result.
- USE a fresh air supply system whenever possible, if not available use an OSHA approved respirator.
- Avoid prolonged skin contact with resin, petroleum, or alcohol based solvents. Personal injury can result.

WARNING: Failure to follow these instructions may result in serious or fatal injury.

CAUTION: Bedliner material is designed to be permanent. Improper masking of vehicle and surrounding area will result in damage.

NOTE: A designated area, such as an undercoating stall or equivalent , should be used to prevent overspray from contaminating other objects and areas.

Spray repair will require use of dispenser and materials readily available through **Ultimate Linings Ltd.**

- Quick Liner® Spray gun dispenser
- Qwik Liner® Spray Cartridge repair material.
- Bedliner Conditioner
- Edge cutting wire tape

All other tools and materials should be readily available shop supplies.

1. Wash the entire cargo bed area and dry thoroughly.
2. Mask off all areas that will not be coated. This includes the vehicle and the surrounding area.

NOTE: When replacing box sections mask at seams or backtape to feature lines whenever possible. Unmask these areas immediately after spraying.

NOTE: If there is not a natural break to tape to it will be necessary to use wire tape .

NOTE: If equipped with bed rails, mask off. Do not remove to apply bedliner material. Proper tolerances will lost.

3. Sand all areas to be coated with 80 grit sand paper or equivalent.
4. Gouge or scrape repairs should be feather edged with a dual action sander or equivalent.
5. Remove the sanding residue with a blow gun and wash entire area with prep solvent.
6. Tailgates will require removal of the access cover and masking off the fastener threads and inner handle area. Hold the access cover in place and elevated by using magnets.
7. Load cartridge into applicator gun , install mixing tip and set air pressure to 110 psi.
8. Purge 13mm. (0.50 in.) of cartridge to be certain of proper mixing .

NOTE: Do not use the last 13mm. (0.50 in.) of cartridge to be certain of proper mix.

9. Apply with tip 60 -75 cm. (2-2.5 feet) away from surface to a total film build of 90 - 120 mils.
10. Once the area is covered, increase your spray distance to approximately 1.2 m. (4ft.). Drop coat the entire area for a uniform finish.

WARNING: Do not remove edge cutting wire tape with bare hands. To prevent injury use pliers or equivalent.

WARNING: Failure to follow these instructions may result in serious or fatal injury.

NOTE: Do not wait more than 24 hours to unmask.

NOTE: If the bedliner has bridged onto the masking tape it will be necessary to use a utility knife to score the liner before separating.

11. Unmask the area .

NON-STRUCTURAL SHEET METAL REPAIR

Safety Notice

CAUTION: All Service and rebuilding instructions contained herein are applicable to, and for the convenience of, the automotive repair industry only.

Proper service and repair is important to the safe, reliable operation of all motor vehicles. The service procedures recommended and described in this publication were developed for professional service personnel, and are effective methods for performing vehicle repair. Following these procedures will help ensure efficient and economical vehicle performance and service reliability. Some service procedures require the use of special tools designed for specific procedures. These special tools should be used as recommended throughout this publication.

It is important to note this publication contains various **Cautions** and **Warnings**. These should be read carefully in order to minimize risk of personal injury or the possibility that improper service may damage the vehicle or render it unsafe. It is important to note that these cautions and warnings cover only the situations and procedures Chrysler Group LLC. has encountered and recommended. Chrysler Group LLC. cannot possibly know, evaluate, and advise the service trade of all conceivable ways in which service may be performed, or the possible hazards of each. Consequently, Chrysler has not undertaken any broad service review. Accordingly, anyone that uses a service procedure or tool that is not recommended in this publication must be certain that neither personal safety, nor vehicle safety will be jeopardized by the service methods they select.

Safety Precautions

WARNING: Always wear an approved respirator, as well as skin and eye protection per adhesive manufacturer recommendations as stated in the product MSDS (Material Safety Data Sheets)

Adhesives:

- MSDS must be available and understood before adhesives are handled.
- All personnel should be instructed on the proper procedures to prevent skin contact with solvents, curing agents, and uncured base adhesives, which could cause allergic reactions or sensitization.

Types of Structural Adhesives

Overview: There are three basic chemistries used in the collision repair industry. The types of adhesives used include Acrylic, Epoxy and Urethane. To achieve optimal results, it is best to use the chemistry that bonds best to the substrate being repaired, is easiest to use and offers the most permanent, non-detectable repair at the most economical repair cost. All three chemistries have their strengths and weaknesses.

NOTE: Structural adhesives that meet Chrysler Group LLC's approved replacement materials specifications include - Mopar #05083855AA, Fusor 112B and 3M 08116

Adhesive Types:

- **Acrylic Adhesives** - Bond all types of bare metals and are excellent for cross bonding aluminum to steel. They have good NVH (Noise Vibration Harshness) properties and some offer anti-corrosion properties, so primers on bare metals are not necessary. Most acrylics have a fast room temperature cure, and are stable with regards to temperature and moisture during cure. However, both of these can effect shelf life. Mix ratio is modestly important although the performance properties can vary with a change in mix ratio. Acrylics are the most forgiving of the three chemistries with regards to mix ratio accuracy.
- **Epoxy Adhesives** - Bond well to ridged and semi ridged plastics and are generally easy to sand and feather edge. Some may be too ridged for flexible substrates and they often require primers on bare metal applications. Epoxies can be heat cured to increase strength and accelerate the curing process. They have a long and stable shelf life. The mix ratio can vary by $\pm 50\%$ and still cure. However, the performance properties will vary when the mix ratio is incorrect. Epoxies are more forgiving than urethanes with regards to mix ratio accuracy.
- **Urethane Adhesive** - Typically flexible and bond well to plastics. However, they usually require primers on metal surfaces to protect against corrosion. Urethanes have good seam sealing and NVH qualities and are frequently the optimal choice for seam sealers. They are sensitive to moisture during cure, packaging and storage. Single component urethanes usually have a much shorter shelf life than two component urethanes. Mix ratios are critical for urethanes. In most cases it cannot vary more than $\pm 5\%$. Therefore, hand mixing is not recommended. Urethanes are the most unforgiving of the three chemistries with regards to mix ratio accuracy.

JOINT AND REPAIR TYPES	REFERENCE
Backer Panel Joint	Backer Panel Joint
Door Skin	Door Skin Replacement
Body Side Aperture	Side Aperture
Metal Fatigue/Stress Cracks	Metal Fatigue/Stress Crack

Backer Panel Joint

Overview: Backer panel procedures may be used to achieve a smooth joint between panel sections. The backer panel works well in areas where there is not enough room to smooth or feather in an overlap joint. The backer panel joint is a common repair for rocker panels, quarter panels and body side apertures.

NOTE: OEM panel replacement such as a quarter panel, side aperture and rocker panel will always require the weld bonding procedure at the pinch weld flange area(s).

Preparation:

NOTE: Be certain vehicle is evenly supported at normal suspension points.

1. Restore structural dimensions as well as all related mating flanges.

NOTE: It will be difficult to abrade the underside mating surface of the original panel, however this is an important step and should be done effectively.

2. Create a 50mm. (2in.) backer panel out of an unused portion of original or new sheetmetal panel, whichever contains the appropriate shape. Be certain it has a precise fit to the back of the panels it will join.
3. All paint, primer, adhesive and any other corrosion protective coatings must be removed from the mating surfaces as well as the backer panels themselves, prior to application of adhesive. Grind a 25mm. (1in.) contact area on all panels where backer panel bonding will take place. The metal should be completely bare and shiny in appearance, if the metal appears pewter in color all of the galvanized coating has not been removed.
4. Pre-fit the backer panel to the panel(s) being joined, to ensure proper fit. If screws will be used to hold the panels in place during curing, dry fit them now to be certain of proper fit later. There should be a 0.8 - 1.6mm. (1/32 - 1/16in.) gap between the two outer panels, no gap on backer panels.

5. Without a mixing tip attached, purge a small amount of structural adhesive from the cartridge. This will ensure an even flow of both components.
6. Attach a mixing tip and dispense a mixing tube's length of adhesive from the cartridge.

Application:

NOTE: Refer to the structural adhesives manufacturer for information on work, handling and curing times.

7. Apply a 10 - 13mm. (3/8 - 1/2in.) bead of structural adhesive to the bare metal mating surfaces of the backer panels. Evenly apply the adhesive over the complete bonding surface. Apply a 10 - 13mm. (3/8 - 1/2 in.) bead of structural adhesive to bare metal mating surfaces. Use a body filler applicator to level the adhesive, making sure to cover all bare metal to protect against corrosion.
8. Position the new backer panel(s), making sure not to separate after contact. Lifting will create air bubbles and weaken the bond. **Adjustments must be made by sliding, not lifting the panel(s).**
9. Clamp tightly and evenly. Adhesive has glass beads that will prevent complete squeeze out. Install screws to the "hard to clamp areas".
10. Remove excess adhesive from all joints prior to adhesive cure.
11. Allow adhesive to cure, per manufacturer recommendations. When fully cured, expect the adhesive to be a little tacky, as this is a normal characteristic of the adhesive.
12. Remove clamps and screws.
13. Repeat procedure for installation of new panel.
14. Remove any remaining adhesive with a grinder or abrasive disc. All adhesive must be removed from the cosmetic repair area to ensure proper adhesion of further repair and refinish materials.
15. Bevel the center of the screw holes and apply fiber-reinforced waterproof body filler to the screw holes and section seam. When cured, sand and apply conventional body filler and block sand as necessary. Prime and paint per paint manufacturer recommendations.
16. Apply inner panel corrosion inhibiting materials (Mopar Cavity Wax part #6804292970 or equivalent).

Door Skin Replacement

Overview: Depending on the type of door to be repaired, a full skin or a belt cut will be required. Belt cut replacement is necessary when a door with a full skin, around the window opening, has an angle that makes it difficult to get tools into to do a quality hem flange installation. A butt-joint is used at this seam.

Preparation:

1. Belt cut skins will require determining and cutting of the sectioning locations on the original panel and on the replacement panel.
2. Remove the door skin by grinding the outer edge (C) until the seam is perforated.
3. Cut around weld nuggets and spot welds with a spot weld cutting bit or similar weld removal tool.
4. If panel is attached with adhesive you may use heat, from a **non-flame** heat source, up to 204°C. (400F°). This will aid in loosening the bond.
5. With an air chisel and a flat bladed bit, remove outer skin and any remaining hem flange.
6. Grind any remaining weld nuggets flush with door frame, and remove all adhesive, paint, E-coating and corrosion protective coatings from the area where the **structural adhesive** will be applied, and where the "butt-joint" is to take place. The metal should be completely bare and shiny in appearance, if the metal appears pewter in color all of the galvanized coating has not been removed.
7. Straighten door flange and any remaining damage on door shell using the hammer and dolly method.
8. The area of the new door skin that will make contact with the door shell will need to be scuffed with a course abrasive pad or ground with a 50 grit grinding disc. This will vary upon adhesive manufacturers, be certain to check adhesive manufacturer recommendations.
9. Dry fit the new panel. Determine where to place clamps to hold the panel in place, as necessary.

CAUTION: Be certain the fit is good from the skin to door and door to door opening. Cured adhesive is extremely strong and will not allow for "adjustments".

10. Without a mixing tip attached, purge a small amount of structural adhesive from the cartridge. This will ensure an even flow of both components.
11. Attach a mixing tip and dispense a mixing tube's length of adhesive from the cartridge.

NOTE: Refer to the structural adhesives manufacturer for information on work, handling and curing times.

Installation:

NOTE: Do not apply adhesive within 25mm. (1in.) of the belt cut location.

12. Apply a 10 - 13mm. (3/8 - 1/2 in.) bead of structural adhesive to bare metal mating surfaces. Use a body filler applicator to level the adhesive, making sure to cover all bare metal to protect against corrosion.

NOTE: When applying adhesives be certain any and all drain holes remain open and clear of obstructions.

13. Apply a second bead of adhesive to ensure proper bead thickness.
14. Position the new panel. If repositioning is necessary slide the panel, do not lift or separate panels. **Adjustments must be made by sliding, not lifting the panel(s).** Apply clamps to hold panel in position, as necessary.

NOTE: There are many tools readily available to aid in the hem flange folding process.

15. Roll the hem flange over. Remove excess adhesive. This will save time, as compared to waiting until cured.
16. Re-check door gap and flushness to the vehicle opening and adjust as necessary.
17. Allow the adhesive to cure per manufacturer recommendations. When fully cured, expect the adhesive to be a little tacky, as this is a normal characteristic of the adhesive. Remove clamps, if used.
18. Remove any excess cured adhesive with a grinder or abrasive disc. All adhesive must be removed from the cosmetic repair area to ensure proper adhesion of repair and refinish materials.

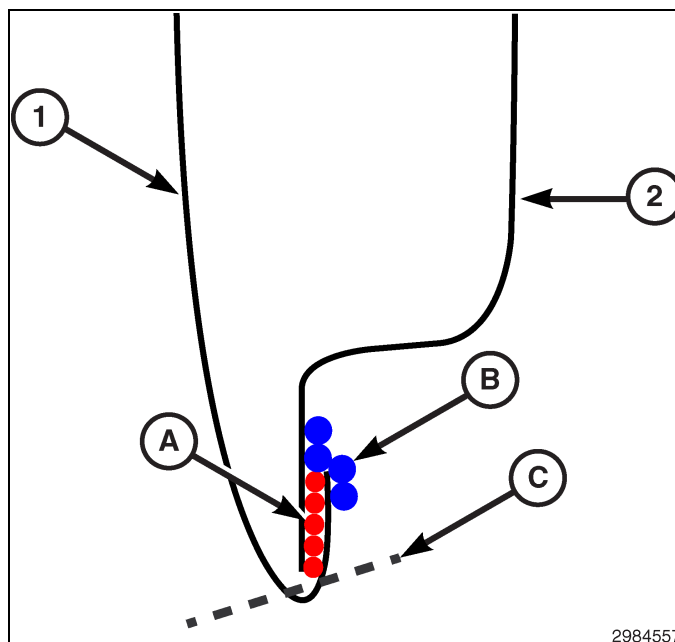

Fig. 21 Door Skin

NOTE: Drain holes must remain clear of obstructions from adhesives and sealers.

1 - DOOR SKIN (OUTER)

2 - DOOR SHELL (INNER)

A - STRUCTURAL ADHESIVE

B - SEAM SEALER

C - HEM FLANGE CUT LINE (BOTTOM EDGE SHOWN, SURROUNDING EDGES TYPICAL)

19. Weld the butt-joint with GMAW (Gas Metal Arc Welding), if a belt cut was used. Clean and dress welds accordingly.
20. Apply fiber-reinforced waterproof body filler to the section seam, as necessary. When cured sand and apply conventional body filler and block sand.
21. Apply an epoxy or anti-corrosion primer. When cured, lightly scuff.
22. Seam seal the entire door. Duplicate the factory seam sealer. Apply a discrete bead around the rest of the door to seal and protect, maintaining the original appearance.
23. Prime and paint per paint manufacturers recommendations.
24. Apply inner panel corrosion inhibiting materials (Mopar Cavity Wax part #68042970AA , or equivalent).

Side Aperture

Overview: Chrysler's recommended repair procedure for body side aperture / quarter panel replacement include butt joints using backer panels with structural adhesive at the sectioning joint, or a welded backer panel with a welded butt joint using GMAW (Gas Metal Arc Welding). Resistance spot welding with structural adhesive, referred to as weld bonding, should be used at all pinch welds and may be used at the drain trough and tail panel areas as well. With the exception of the sectioning joint, the rule to follow is "Re-assemble as it was built from the OEM". For further information refer to Weld / Weld Bonding section. GMAW (plug or puddle) welds may be used in place of STRSW (Squeeze Type Resistance Spot Welding) only in areas that specifically use spot welds and in areas that access limitations will not allow STRSW. GMAW cannot be used in the weld bonding process. Never weld with GMAW within 25mm. (1in.) of any area where structural adhesive is used. The weld "heat zone" will destroy the properties of the adhesive.

Vehicle design will determine if the sectioning location is to be in the pillar or the roof line area. Reference the vehicle specific Body Repair Manual to verify if any specific locations or warnings apply to body side aperture sectioning locations.

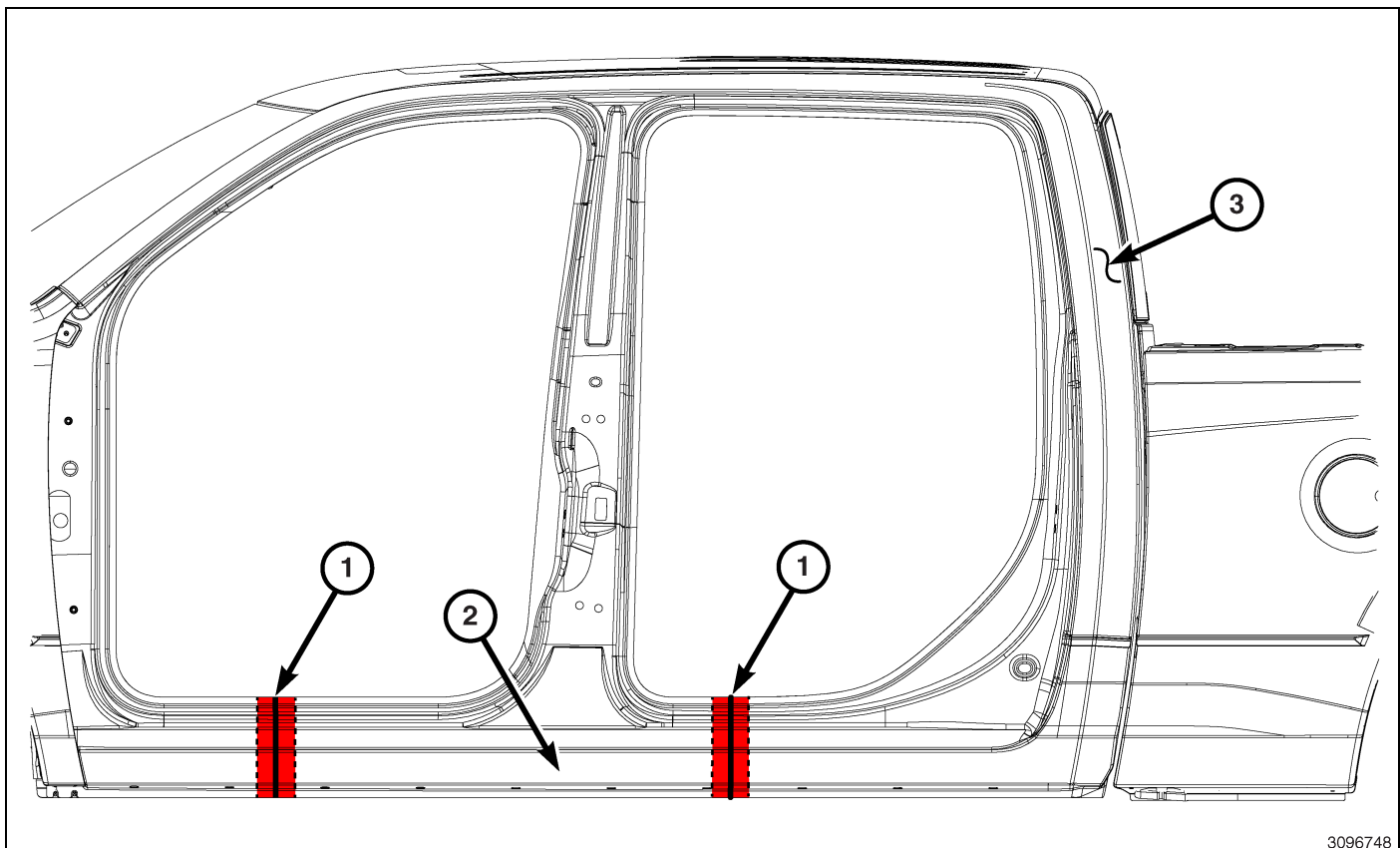

Body Side Aperture

- 1 - SECTION JOINT WITH BACKER PANEL
- 2 - ROCKER PANEL
- 3 - BODY SIDE APERTURE

Preparation:

NOTE: Be certain vehicle is evenly supported at normal suspension points.

1. Restore structural dimensions as well as all related mating flanges.
2. Once sectioning locations have been established, cut original and replacement panels at the pre-determined locations. Remove spot welds within sectioned parameter.

NOTE: Be careful not to destroy any areas that may be able to be used as backer panels.

3. If panel is attached with adhesive, you may use heat, from a **non-flame** heat source, up to 204°C. (400F°). This will aid in loosening the bond.
4. Use an air chisel with a flat bladed bit to remove original panel.
5. Using a hammer and dolly, restore any and all damage to mating surfaces.
6. Create backer panels to be used at butt joints. Refer to Backer Panel Joint

NOTE: It will be difficult to abrade the underside mating surface of the original panel, where backer panel is to be used, however this is important step and should be done effectively.

7. Grind all mating surfaces with a 50 grit grinding disk. Remove all adhesive, sealers, paint, E-coating and corrosion protective coatings from the area where the structural adhesive and welds will be applied. The metal should be completely bare and shiny in appearance, if the metal appears pewter in color all of the galvanized coating has not been removed.
8. Pre- drill any GMAW plug / puddle weld holes that may be necessary, with a 8mm. (5/16in.) hole.
9. With the aid of an assistant, dry fit the panel. Apply clamps to hold panel in place, making note of locations. Install screws where accessibility prohibits the use of clamps. This will aid in proper alignment during installation.
10. Without a mixing tip installed, purge a small amount of structural adhesive from the cartridge. This will ensure an even flow of both components.
11. Attach a mixing tip and dispense a mixing tube's length of adhesive from the cartridge.

NOTE: Using scrap metal and adhesive, make test coupon samples and perform peel test to ensure your STRSW equipment is ready to apply welds as required. Refer to the Weld / Weld Bonding section of the Body Repair Manual for further information.

NOTE: Refer to the structural adhesives manufacturer for information on work, handling and curing times.

Installation:

12. Install backer panels, refer to Backer Panel Joint
13. Apply 10 - 13mm. (3/8 - 1/2in.) bead of structural adhesive to the area where the two panels are to be bonded and weld bonded. **Do not apply to areas that will only be STRSW or GMAW welded.**
14. Smooth the adhesive with a body filler spreader or equivalent, to cover all bare metal surfaces. Apply a second bead of adhesive to ensure proper adhesive thickness.
15. With the aid of an assistant place the panel to the vehicle. If the panel needs to be adjusted, slide the panel.

NOTE: Adjustments must be made by sliding, not lifting the panel(s). Lifting will cause air bubbles and weaken the bond.

16. Install clamps and screws to locations determined during the dry fit process
17. Remove all squeeze out of adhesive, prior to curing.

NOTE: Structural adhesive manufacturers will vary on time allowed for completion of STRSW in weld bond zones. Check and follow adhesive manufacturer recommendations.

18. Apply STRSW to weld bond area immediately.
19. Once fully cured, remove clamps and screws. When fully cured, expect adhesive to remain a little tacky, as this is a normal characteristic of the adhesive.
20. Complete STRSW and / or GMAW (plug / puddle) welds.
21. Finish / Dress the welds as necessary. If screws were necessary bevel the screw holes. Prepare the joint and screw holes by grinding the area with 50 grit grinding disc. Get in seams as best as possible without thinning the metal.
22. Remove any excess cured adhesive with a grinder or abrasive disc. All adhesive must be removed from the cosmetic repair area to ensure proper adhesion of repair and refinish materials.
23. Apply fiber-reinforced waterproof body filler to screw holes and joint. Complete the repair using conventional body filler, and block sanding.
24. Apply an epoxy or anti-corrosion primer. When cured, lightly scuff and then apply seam sealer as necessary.

25. Prime and paint per paint manufacturer recommendations.
26. Apply inner panel corrosion inhibiting materials (Mopar Cavity Wax part #68042970AA, or equivalent).

Metal Fatigue/Stress Crack

Overview: On rare occasions you may encounter metal fatigue, also referred to as stress cracks. This will appear as a crack starting at an edge and trailing away. Follow these steps for a proper repair:

1. Locate the trailing end of the crack and drill a 3mm. (1/8in.) hole at the very point at which it stops. This is referred to as "Stop Drilling".
2. Remove all contaminants and coatings including primer, paint and anti-corrosion, from the repair area. Surface should be clean and shiny (if pewter in color then anti-corrosion has not been removed).
3. Stitch weld the seam/crack closed using GMAW. Follow welding guidelines as found in Weld/Weld Bonding section of the Body Repair Manual.
4. Dress the welds as necessary. **Careful not to thin the base metal.**
5. Depending on the location and visibility of the repair surface refinishing will vary from body filler, finishing and painting to simply applying an epoxy or anticorrosion primer and rubberized undercoating, Mopar part #05093417AA or equivalent.
6. Apply inner panel corrosion inhibiting materials (Mopar Cavity Wax part #68042970AA , or equivalent).

WELDING AND WELD BONDING

Safety Notice

CAUTION: All Service and rebuilding instructions contained herein are applicable to, and for the convenience of, the automotive repair industry only.

The service procedures recommended and described in this publication were developed for professional service personnel, and are effective methods for performing vehicle repair.

It is important to note this publication contains various **Cautions** and **Warnings**. These should be read carefully in order to minimize risk of personal injury or the possibility that improper service may damage the vehicle or render it unsafe. Chrysler Group LLC. cannot possibly know, evaluate, and advise the service trade of all conceivable ways in which service may be performed, or the possible hazards of each. Consequently, Chrysler has not undertaken any broad service review. Accordingly, anyone that uses a service procedure or tool that is not recommended in this publication must be certain that neither personal safety, nor vehicle safety will be jeopardized by the service methods they select.

Safety Precautions

WARNING:

- **When Welding and/or working with Adhesives always wear safety goggles and gloves to prevent contact with chemicals and to prevent weld spatter, sparks, and sharp metal from causing bodily injury.**
- **Wear an approved respirator while welding and during the application of adhesives to prevent inhalation of harmful vapors.**
- **Always remove NVH (Noise Vibration and Harshness) foam from welding repair area, as material is flammable.**

WARNING: Failure to follow these instructions may result in possible serious or fatal injury

Welding

- Comply with all federal, state and local regulations to avoid any injuries due to shock, fires, fumes, sparks and liquids.
- All flammable materials or liquid should be stored in tightly sealed and labeled containers, and used only in well ventilated areas.
- No spark producing equipment should be permitted in any area where flammable materials are being handled or stored.

Adhesives:

- Material Safety Data Sheets (MSDS) must be available and understood before adhesives are handled.
- All personnel should be instructed on the proper procedures to prevent skin contact with solvents, curing agents, and uncured base adhesives, which could cause allergic reactions or sensitization.

Introduction

The purpose of this document is to clearly explain the welding options available to the collision repair technician and how to determine that welding repairs are made properly. The primary types of welding covered in this section are STRSW (Squeeze Type Resistant Spot Welding), GMAW (Gas Metal Arc Welding) and Weld Bonding (a combination of STRSW

and structural adhesive). Proper training and weld testing are required to ensure that a safe, high quality, vehicle repair is made.

INDEX	REFERENCE
Panel Removal	Panel Removal
Key Points of a Welding Repair	Key Points of a Welding Repair:
Modified Lap Joint	Modified Lap Joint
Requirements of a Welding Repair	Requirements of a Welding Repair
Types of Welding (STRSW, GMAW and Weld Bonding)	Types of Welding
Weld Process (STRSW, GMAW and Weld Bonding)	Weld Processes:
Minimum Weld Nugget Requirement Chart	Minimum Weld Nugget Requirement Chart
Training and Qualification	Training and Qualification

Panel Removal

WARNING: Always Wear Safety Goggles, Work Gloves, Hearing Protection and a Dust Mask when removing welded panels this way. Failure to follow these instructions could result in serious or fatal injury.

When removing panels and components for replacement, care must be taken not to damage the underlying component. On welded and "Weld Bonded" panels spot welds must be removed using a spot weld cutting type tool, or equivalent. On panels that are adhesive bonded or weld bonded it is acceptable to use heat up to **204°C. (400°F.)**, from a **Non-Open Flame** heat source. This will loosen the bond, so less damage is inflicted to the mating surface. After panel is removed, any remaining weld nugget should be ground smooth. Cut-off wheels should not be used, as there is potential to remove material from the base material which would weaken the final repair. Place an air hammer with a flat bladed chisel bit (or equivalent) in between panels and remove the panel. Care should be taken as to not damage mating flanges and the surrounding components.

Key Points of a Welding Repair:

- Poor fit up will adversely affect weld quality and may result in a weld failure due to excessive metal stretching around the nugget.
- Clamps should be used to bring parts together and hold them in position.
- Clamps should be insulated when using STRSW to control weld current shunting (This can be accomplished with specialized clamps or by placing an insulating material such as cardboard between the clamp jaws and the panels.)
- Number, size and location of welds should closely duplicate the original assembly. Placement of the new weld should NOT be within a 6mm. (0.25in.) of where the original weld was located. Placement of a new weld over an original weld location may lead to metal fatigue or poor weld quality.
- Surface of the steel parts should be clean and free of scale, rust, paint, cured adhesives/sealers and any other contaminants that could adversely affect the quality of the weld joint. This includes the removal of any E-coat applied to the service part within 25mm. (1in.) of any welds. (Proper corrosion protection must be installed when repairs are complete.)
- If the joint originally had adhesive, all E-coat must be removed where the adhesive is to be reapplied.
- "Weld-thru" primers are not recommended anywhere STRSW or GMAW are used.
- Do not remove base material from the base panel when releasing welds.

NOTE: Chrysler Group LLC recommends the same quantity of welds as the original panel, but placement of the new weld should NOT be within a 6mm. (0.25in.) of where the original welds were located. Placement of a new weld over an original weld location may lead to metal fatigue or poor weld quality.

Requirements of a Welding Repair

The number one requirement of any welding repair is to restore the vehicle to its OEM condition. Materials and technologies should duplicate original OEM conditions as much as possible. To meet this requirement, the technician must ensure the following:

- Panel layering (shingling) is the same as original
- Part fit up is correct

- Equivalent sealers and/or adhesives are utilized
- Welds are replaced in the same size, quantity and location
- "Weld-thru" primers are NOT recommended
- Structural adhesives and sealers must be replaced where they were located

A significant amount of structural adhesive is used at the OEM to improve joint strength. It may be difficult to determine if the material between the panels is an adhesive or a sealer, and for this reason, the following guideline should be used: **If in doubt, use a two-component, corrosion inhibiting, structural adhesive.** GMAW welding is not recommended within 25mm. (1in.) of the adhesive as it creates heat that will destroy the adhesive. STRSW on the other hand, can weld through the adhesive and will not destroy its properties.

NOTE: Structural adhesives that meet Chrysler materials recommendations for adhesive strength and corrosion protection qualities include Mopar #05083855AA, Lord Fusor #112B and 3M #08816

Modified Lap Joint

NOTE: Parts shown for example purposes only. Emphasis is on joint design and proper plug weld placement

The repair joint is a combination lap-joint (1) and butt-joints (2) – the panels are lapped in the flat areas and butted in contoured locations and at weld flanges. The graphic better illustrates this process.

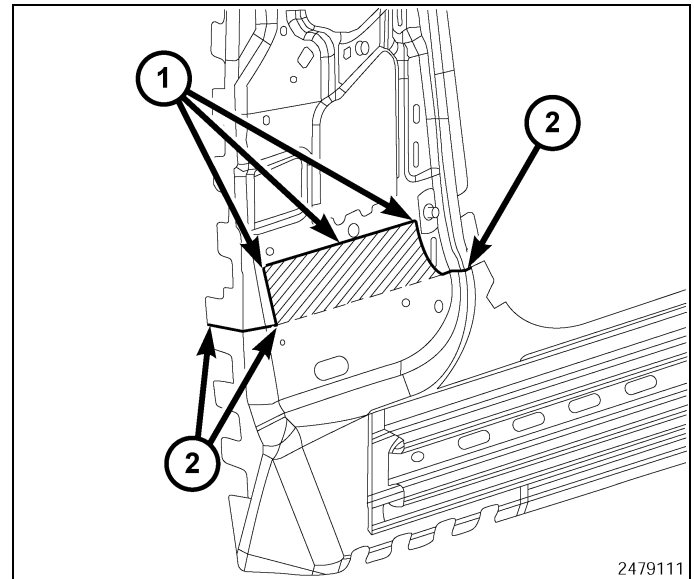
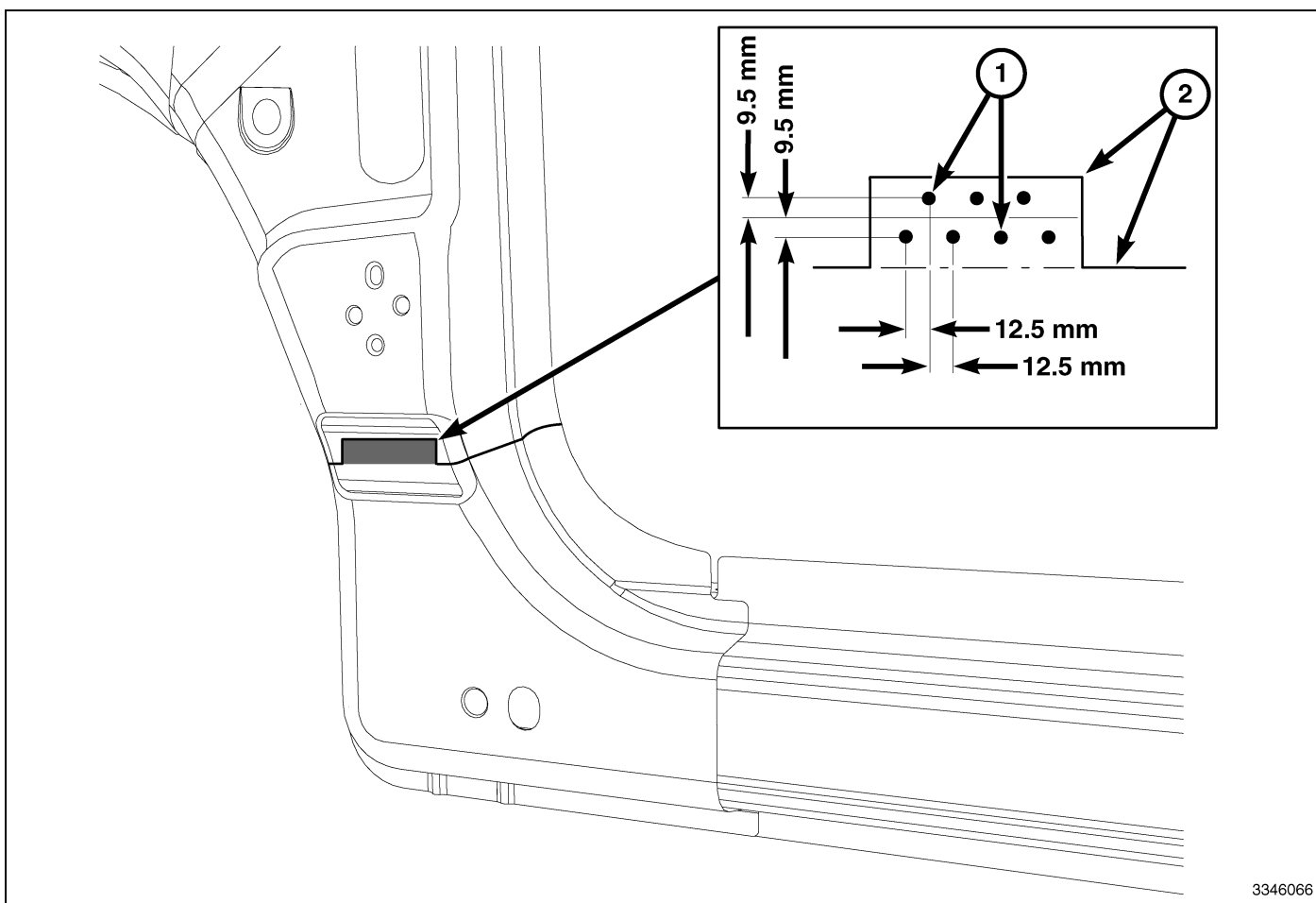

Fig. 22 Modified Lap Joint

1 - LAP-JOINT WELDS

2 - BUTT-JOINT WELDS



3346066

Plug Weld Layout

1 - MIG PLUG WELDS

2 - MIG SEAM WELD

The MIG plug welds, or "puddle welds" should be made after drilling 8 mm (5/16 in) holes and should be staggered 12.5 mm (0.5 in) apart following the centerline of the lap and should be alternating above and below the centerline 9.5 mm (3/8 in.).

In the lap-jointed area, staggered MIG plug welds (1) are used to augment the joint and **all edges** of the lapped panel seam (2) should be **completely** welded.

Types of Welding

STRSW (Squeeze Type Resistant Spot Welding)

- STRSW relies on the resistance of the material being welded to create heat as a current is passed through. The materials being welded are squeezed together, and as current passes through, resistance causes heat buildup. The force of the tips and the heat from the current allow the materials to fuse together. The current is removed and the force from the welding tips is held during a cool down cycle. When the cool down cycle is complete, the pressure is released and the next weld is positioned.
- Learning how to create weld coupons, refer to (Fig. 23) and then performing a destructive test using these coupons, is the key to successfully using STRSW. Chrysler Group LLC requires a physical test using test coupons and the methods outlined in this document to test welds prior to making repairs.
- Tip condition is very important for producing proper welds. Inspect tips often and either dress or change per equipment manufacturer recommendations.
- High-quality welding equipment must be used or welds may be inadequate. Also, the equipment must be able to produce repeatable welds from the beginning of the repair to the end.

GMAW (Gas Metal Arc Welding or "MIG")

- GMAW is an arc welding process where the electrode wire is fed through a weld gun and is surrounded by a shielding gas. The term MIG comes from early uses on aluminum where argon was used as shielding gas and the process was referred to as Metal Inert Gas welding. The GMAW process is currently the most common in the uni-body repair environment.

Weld Bonding

- A method of joining metals using STRSW in conjunction/combination with a structural adhesive.
- Weld bonding provides the customer with a superior repair as compared to the traditional plug/puddle welding process using GMAW. Structural adhesive should not be used in a joint that did not originally contain it.
- The repair joint or seam should duplicate the OE build as closely as possible, unless otherwise stated by vehicle manufacturer.

NOTE: Chrysler Group LLC. DOES NOT approve or endorse the use of structural adhesives alone in the replacement of body panels.

Weld Processes:

STRSW (Squeeze Type Resistance Spot Welding)

Applications

- With advancements in equipment technologies, STRSW is not restricted to light gauge sheet metal any longer. Heavier gauges of high strength and coated steel, currently used in vehicle structures, can now be welded in the field, providing destructive testing is performed on each combination. This is to ensure quality welds are being maintained.

Equipment Requirements

- Equipment must produce two sided welds
- Equipment must have been tested to SAE J2667 with satisfactory results obtained
- Equipment must have the capability to create welds that comply with the Minimum Weld Nugget Requirement Chart
- Technician must have the appropriate sheet metal measuring equipment to ensure their welds meet the minimum weld nugget size for the actual panels being welded

Minimum Weld Nugget Requirement Chart

*Governing Metal Thickness (GMT)	**Minimum Weld Nugget Diameter
0.64mm. - 0.79mm.	3.5mm.
0.8mm. - 0.99mm.	4.0mm.
1.0mm. - 1.29mm.	4.5mm.
1.3mm. - 1.59mm.	5.0mm.
1.6mm. - 1.89mm.	5.5mm.
1.9mm. - 2.29mm.	6.0mm.
2.3mm. - 2.69mm.	6.5mm.
2.7mm. - 3.04mm.	7.0mm.

*Governing Metal Thickness (GMT) = The minimum weld nugget for two thickness welds shall be based on the thinner of the two sheets being welded. The minimum weld nugget diameter for three thickness welds shall be based on the middle gauge of the three panels being welded (not necessarily the middle panel).

**Minimum nugget diameter should be measured with a venire caliper. If the weld is not round, measure the major and minor diameter and average.

Equipment Limitations

- Each brand/model is limited to material capacity that can be welded
- The facility power supply can also impact equipment performance

Access Limitations

- Due to the existing structure of the vehicle being repaired, each weld must be evaluated for feasibility. Due to power limitations of the equipment, tongs that are long and deep enough for certain welds may not be available, and the weld will need to be made by another method.

Preparation

CAUTION: All NVH foam must be removed from the repair area of the vehicle, as material is flammable.

- Prior to making repairs with STRSW, weld coupons must be created for testing. The test joint must be an exact duplicate of the original joint, including layering and adhesive application. The testing is required to ensure the repair restores the vehicle to its originally produced condition using the minimum weld nugget requirement chart.
- To correctly identify the material being welded or tested, the technician must possess an accurate material thickness gauge
- No "improvements" to the vehicle design are allowed as this could have a negative impact on the vehicle as a whole. The repair should mirror what was used on the vehicle at the assembly plant.
- Note, the weld is affected by more than just the thickness or number of panels being welded, but also material coatings. Zinc based anti-corrosion coatings (i.e., galvannealing, galvanizing), sealers, adhesives, and E-coat will affect welder performance. Any sandwich type coatings will increase weld time (and current in some types of STRSW welders) required to accomplish an acceptable weld nugget.
- When preparing an E-coated panel for STRSW the E-coat must be removed from both of the mating flanges within 25mm. (1in.) of any flange. Corrosion protection is required anytime you remove E-coat. A scuffing disc should be used to remove the E-coat without damaging other sheet metal coatings
- If the panel originally had structural adhesives it should be reapplied prior to welding. The adhesive should have a corrosion inhibitor and cover all bare metal.
- Prior to creating weld coupons and the final body repairs, all coatings and dirt/road debris must be removed.

Testing

- Weld coupons identical to the repair situation need to be made prior to performing any repair. These coupons must be tested (peel test) to determine if the weld nugget meets the minimum size outlined above in the Minimum Weld Nugget Requirement Chart. Keep in mind that different material coatings, coating thickness, material thickness, and joint configurations have a direct impact on nugget size.

GMAW (Gas Metal Arc Welding or "MIG")

Applications

- Sheet metal repairs where STRSW is not available or practical, and truck frame repairs.
- The most common usage of GMAW on uncoated or galvanneal coated steel will utilize a 75% Argon - 25% CO₂ shielding gas mix, and AWS specification ER70S6 wire. When welding galvanized material, Flux Core Arc Welding (FCAW) using AWS specification E71T-GS wire should be used to avoid weld porosity from the zinc in the galvanizing.

Weld Process

COMPONENT PARTS	TRUCK FRAME		BODY SHELL EXTERIOR & UNDERBODY PANELS			
	Zinc and Zinc Iron Alloy coated sheet steels					
WELDING PROCESS	GAS METAL ARC (Note: 1)	FLUX CORED ARC	GAS METAL ARC (Note: 1)	MIG BRAZE (Note: 2)	GAS METAL ARC (Note: 1)	FLUX CORED ARC
Material Type	High Strength and Structural Quality Steels which includes HSLA, Martensitic, and Dual Phase materials					
Material Thickness Range	2 mm - 4 mm		0.6 mm - 1.02 mm		>1.02 mm - 3.0 mm	
ELECTRODE TYPE (AWS SPEC. A5.18)	AWS CLASS. ER70S-6	AWS CLASS. E71T-11 (Note 3)	AWS CLASS. ER70S-6	AWS CLASS. ERCuSi - A Silicon Bronze	AWS CLASS. ER70S-6	AWS CLASS. E71T-11 (Note 3)
ELECTRODE SIZE	0.035	0.045	0.023 - 0.025	0.035	0.035	0.045
ELECTRODE MAKER	Lincoln®	Lincoln® NR-211-MP	Lincoln®		Lincoln®	Lincoln® NR-211-MP

Weld Process, continued

COMPONENT PARTS	TRUCK FRAME		BODY SHELL EXTERIOR & UNDERBODY PANELS			
WIRE FEED SPEED (in/min)	245-250 Vertical Down 70-90 Flat & Horizontal	110 Vertical Down 70-90 Flat & Horizontal	95-115 All Welds	150-155 Flat & Horizontal	245-250 Vertical Down 70-90 Flat & Horizontal	110 Vertical Down 70-90 Flat & Horizontal
TRAVEL SPEED (in/min)			10			
VOLTAGE	19-20	15-18	16-19	18-19	19-20	15-18
POLARITY	DCEP	DCEN	DCEP	DCEP	DCEP	DCEN
GAS FLOW (cfh)	25-35	N/A	25-35	25-35	25-35	N/A
ELECTRICAL STICKOUT (in)	1/2 - 5/8	3/8 - 1/2	1/2 - 5/8	5/8 - 3/4	1/2- 5/8	3/8 - 1/2
GAS TYPE	75% Ar 25% CO2	N/A	75% Ar 25% CO2	100% Ar	75% Ar 25% CO2	N/A
TYPE OF ARC TRANSFER	Short Circuit		Short Circuit	Pulse	Short Circuit	

These Procedure Specifications are appropriate as of this publication. Procedures may be superseded with new spec's at a later date.

Always process to the thinner material thickness (TMT)

All persons performing welding must be qualified to weld in all positions.

NOTE:

1. **Must remove Zinc Coating on both sides of metal at the weld zone.**
2. **MIG Braze welding process requires use of Pulse Arc® or STT® welding machine.**
3. **Must use Lincoln® product since E 71T-11 product differs from other suppliers.**

Equipment Requirements

- The preferred GMAW welder will be a 220V. unit with minimum output capacity of 150 amps (250 amps suggested to avoid equipment limitations).

Limitations

- Welds must be "dressed", or ground down before applying topcoats.
- GMAW cannot weld through paints, sealers, or adhesives. Additionally, the zinc used in coated steels can lead to reduced weld strength due to porosity. This porosity problem on materials with heavy coatings can be dealt with by using FCAW.
- Due to the heat affected zone, structural adhesives cannot be applied within 25mm. (1in.) of GMAW welds.

Testing

- Weld coupons identical to the repair situation need to be created to help set up the welding equipment and weld process. These coupons then should be destructively tested to ensure proper quality welds are being made

Post Weld Procedures

- When welding has been completed, welds in cosmetic locations must be dressed.
- Welds will need to be smoothed down to the height of the surrounding panel without any thinning of the sheet metal. This can be accomplished using one of many sanding or grinding products available in the aftermarket.
- Slag must always be removed prior to refinishing to restore corrosion protection and appearance.
- Corrosion inhibiting materials must be applied to seal the weld zone from future corrosion.

Weld Bonding

NOTE: Structural adhesive manufacturers will vary on time allowed for completion of STRSW in weld bond zones. Check and follow adhesive manufacturer recommendations.

Application

- Weld bonding is the STRSW welding process utilizing structural adhesive between the panels that are resistance welded together. The adhesive creates a very stiff structure, while the welding eliminates concerns of the adhesives' peel strength.
- Additionally, the adhesive acts as a sealer and provides a high level of corrosion protection.

Sealers and Adhesives

- Sealers are materials placed on top of a seam to control water and air intrusion.
- Adhesives, providing structural improvements, are found between panels welded together. Adhesives also provide the qualities of sealers when applied correctly.
- The Chrysler Group LLC. recommendation is to replace any suspected adhesive with a two-component, corrosion inhibiting structural adhesive when any repairs are made, providing the STRSW process is applicable. The structural adhesive must meet or exceed Chrysler Group LLC. MS CD507

Test Weld Coupon

NOTE: Periodically check the electrodes tips to determine weather the faces have been contaminated, damaged or increased in size. If any of these conditions have occurred, replace or re-face the electrode tips per equipment manufacturer recommendations.

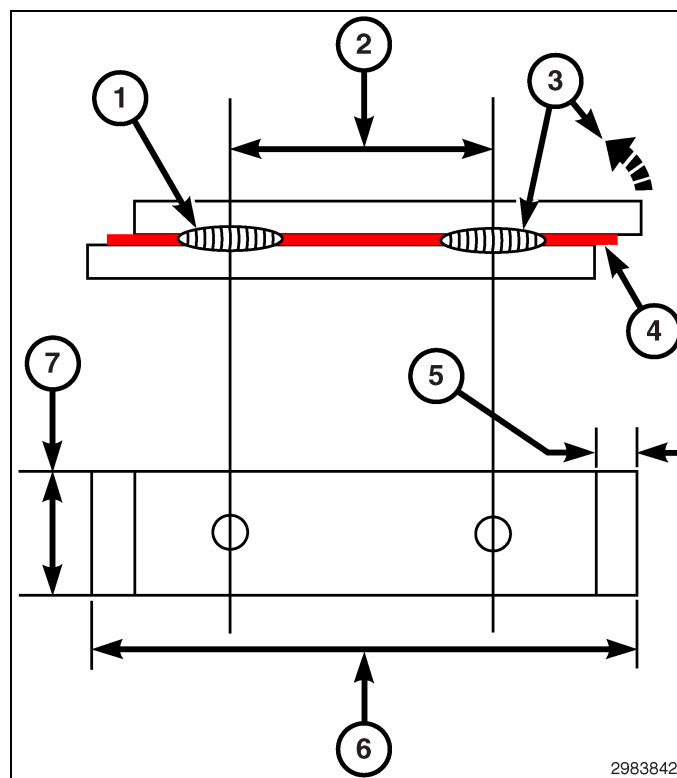

Fig. 23 Weld Coupon

1 - FIRST WELD TOWARD END OF COUPON, AT LEAST 12.5mm. (0.5in.) FROM ANY EDGE

2 - DISTANCE MUST EQUAL THE SPACING FROM THE REPAIR WELD TO THE CLOSEST EXISTING WELD ON THE VEHICLE

3 - TEST THE SECOND WELD BY PEELING APART IN DIRECTION SHOWN (USING PLIERS OR EQUIVALENT)

4 - STRUCTURAL ADHESIVE

5 - APPROXIMATELY 13mm. (0.5in.)

6 - APPROXIMATELY 100mm. (4in.)

7 - APPROXIMATELY 25mm. (1in.)

Same Current Level Used For Both Welds

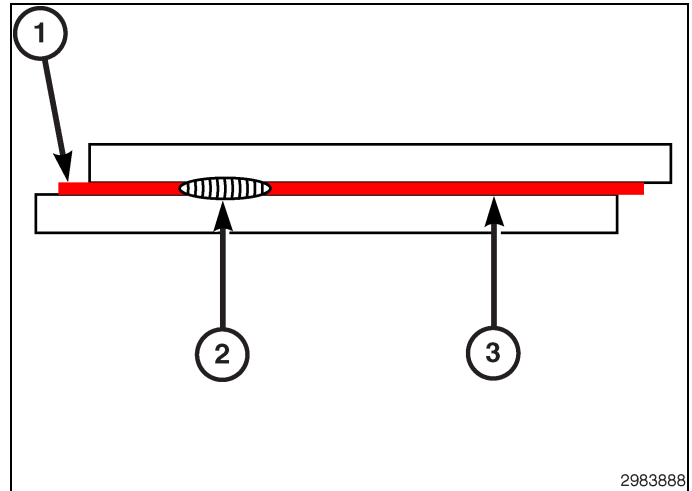

Fig. 24 Current Level Low for Both Welds

- 1 - STRUCTURAL ADHESIVE
- 2 - WELD TOO SMALL
- 3 - WELD NON-EXISTENT

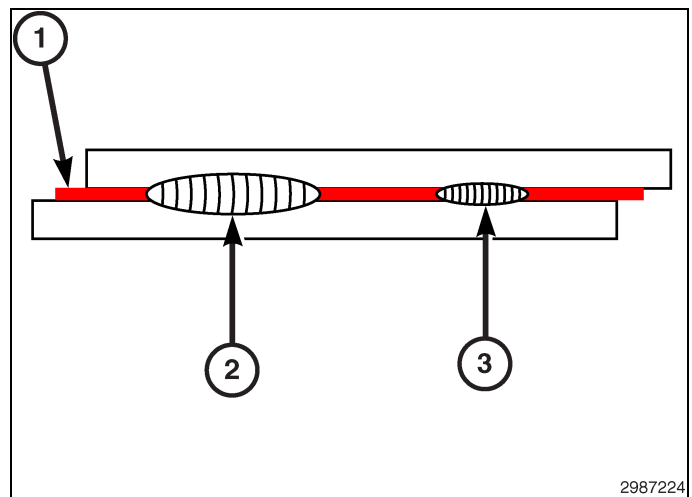

Fig. 25 Current Level Medium for Both Welds

- 1 - STRUCTURAL ADHESIVE
- 2 - WELD CORRECT SIZE
- 3 - WELD TOO SMALL

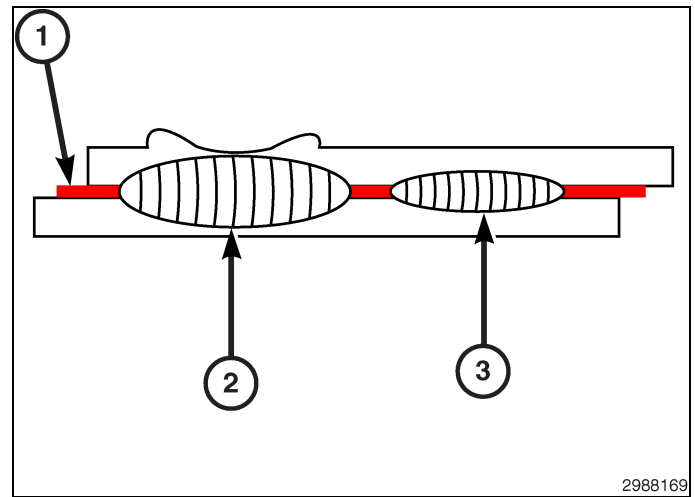

Fig. 26 Current Level High for Both Welds

- 1 - STRUCTURAL ADHESIVE
- 2 - WELD HAS HEAVY EXPULSION OF METAL AND SURFACE MARKINGS
- 3 - WELD CORRECT SIZE

Current Level Adjusted to Provide Acceptable Welds

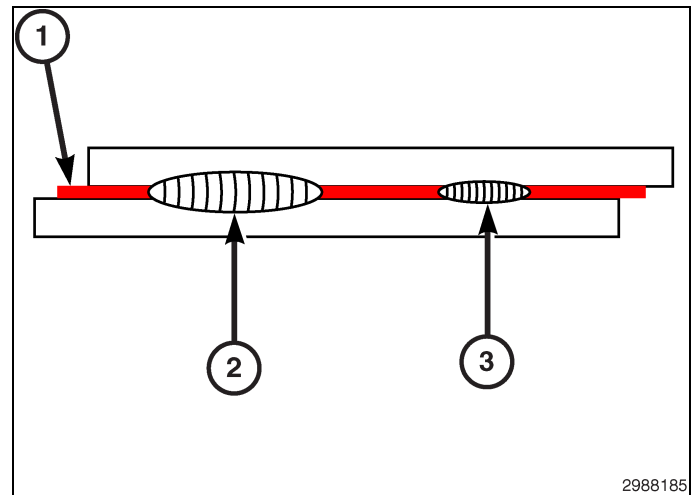

Fig. 27 Current Level Low for Both Welds

- 1 - STRUCTURAL ADHESIVE
- 2 - WELD CORRECT SIZE
- 3 - WELD TOO SMALL

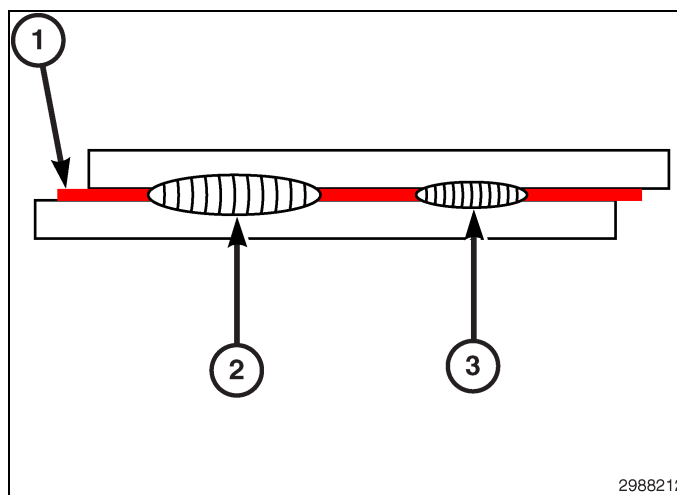

Fig. 28 Current Level Medium for Both Welds

1 - STRUCTURAL ADHESIVE

2 - WELD CORRECT SIZE

3 - WELD TOO SMALL

1. Select the proper spot welding "arm" which provides the best access to the areas of the vehicles where the spot welds are to be made.
2. Obtain metal of the same thickness and coating (i.e., bare, galvaneal, or galvanized) to be welded. This metal will be used for spot welder set up. Damaged sheet metal taken from the vehicle being repaired may be used if it is from the area from which the work is to take place. The sheet metal must be flat, free of cracks, wrinkles and scored metal.
3. Using the procedure outlined, (Fig. 23), prepare the test coupons.
4. Clean and prepare both mating coupons. If using adhesives, verify the recommendations of the adhesive manufacturer. All contaminants such as rust scale, dirt, paint, and existing sealers and adhesives must be removed. Remove any E-coat within 25mm. (1in.) of where the welds are to be placed.
5. If the panel joint originally contained structural adhesive, it should be applied to the coupon at this time.
6. Install the equipment manufacturers recommended electrode tips.
7. Adjust the welding electrode tip force, and clamp time per manufacturer recommendations.

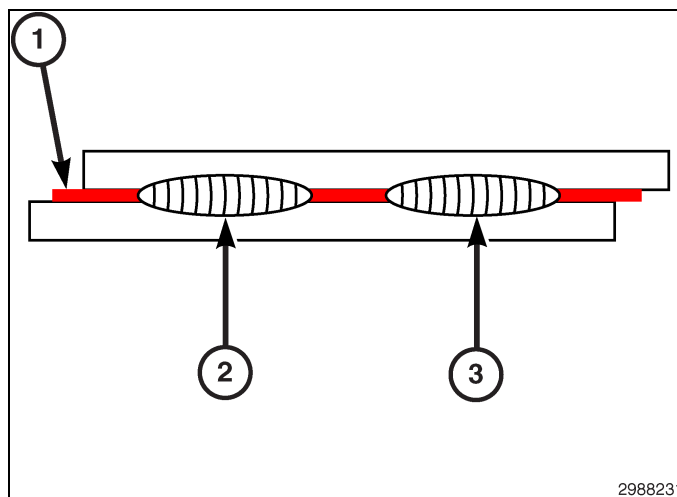

Fig. 29 Current Level Medium (2) High (3)

1 - STRUCTURAL ADHESIVE

2 - WELD CORRECT SIZE

3 - WELD CORRECT SIZE

NOTE: Galvaneal and galvanized coated steel will require more force

8. As shown in (Fig. 23), place first weld at a position at least 12.5mm. (0.5 in.) away from end weld coupons. Then make the second weld. The weld spacing should be the same distance as the original welds or the closest existing weld, whichever is the least on the vehicle being repaired.
9. Destructively test the **second** weld to determine the size of the resistance spot weld produced (see examples in (Fig. 24) If the weld is insufficient, adjust the welder per the welder manufacturer recommendations and repeat steps 7,8 and 9 until the proper weld size is achieved.

NOTE: If the first weld becomes too "hot" before the second weld reaches the correct size, reduce the current settings for the first weld and continue increasing the current setting for the second weld until the proper size for the second has been reached.

Final Weld Preparation

CAUTION: All NVH foam must be removed from the repair area of the vehicle, as material is flammable.

1. Visually verify that mating flanges are free of scale, rust, dirt, paint and cured adhesives/sealers, as well as wrinkles. If cracked, wrinkled or scored metal exists the condition needs to be corrected at this time.
2. E-coat within 25mm. (1in.) needs to be removed for STRSW. If Weld Bonding, E-coat should be ground off completely along seam.

NOTE: Corrosion resistance coating (i.e., galvanized, galvanized) should not be removed during cleanup of components.

3. If adhesive is to be used, apply it at this time. Clamp the component to the vehicle.

NOTE: Insulated clamps should be used, as not to shunt the weld current.

4. Visually verify that the welds to be made **will not** be placed directly over an existing weld.
5. After verifying that the welder control settings are the same required to produce the second weld on the test coupons, make the welds on the vehicle.

NOTE: Structural adhesive manufacturers will vary on time allowed for completion of STRSW in weld bond zones. Check and follow adhesive manufacturer recommendations.

6. If adhesive was used, clean up any excessive squeezeout prior to adhesive curing.

Training and Qualification

Training

As with any equipment, proper training is required, and in the case of welding equipment this is no exception. The goal of automobile facilities and technicians is to restore the vehicle to its OEM condition.

Training must be considered a two-fold process:

- The technician must be well versed in how the equipment operates, how adjustments are made and what effects those adjustments have on the weld. The technician must also clearly understand the maintenance of the equipment and the impact of poor maintenance on welds and equipment longevity.
- The second and most important, aspect of the training, is weld quality confirmation. Destructive testing of weld coupons must be performed to ensure the minimum weld size is created. Physical appearance of the weld is not enough to determine the quality of the weld. Additionally, poor welds may also reduce the durability, or quality, of the repaired vehicle in time.

It is required that technicians have received training regardless of the welding equipment or method they utilize. Both training in the specific field of welding, and the particular equipment, are necessary to ensure safe, durable, quality welds are obtained.

Qualification

To demonstrate welding skill, it is highly important that technicians obtain certification from an organization such as the American Welding Society (AWS) or a certificate from the Inter-Industry Conference on Auto Collision Repair (ICAR).

BODY SIDE REPAIR

CAUTION:

- All restraint systems should be disabled before beginning repairs.
- Electronic modules located within 305 mm (12 in.) of any welding should be isolated.
- Protect vehicle from weld spatter damage.
- Vehicle service manual should be referenced for guidelines and warnings.

NOTE: Service assemblies for body components may be disassembled if utilization of the subcomponents is more appropriate to the repair or to reduce vehicle disruption.

The inner aperture panel on the Ram truck (DS) may be sectioned in several areas providing the prescribed methods below are adhered to. Since the inner panel is a structural component, it is important that the overall cab integrity is maintained during a repair.

The outer aperture panel (class "A" surface) may be installed following the guidelines published in the Chrysler "Non-Structural Sheet Metal Repair Manual" publication. The location of the joint should not be performed at a door hinge or striker mounting location.

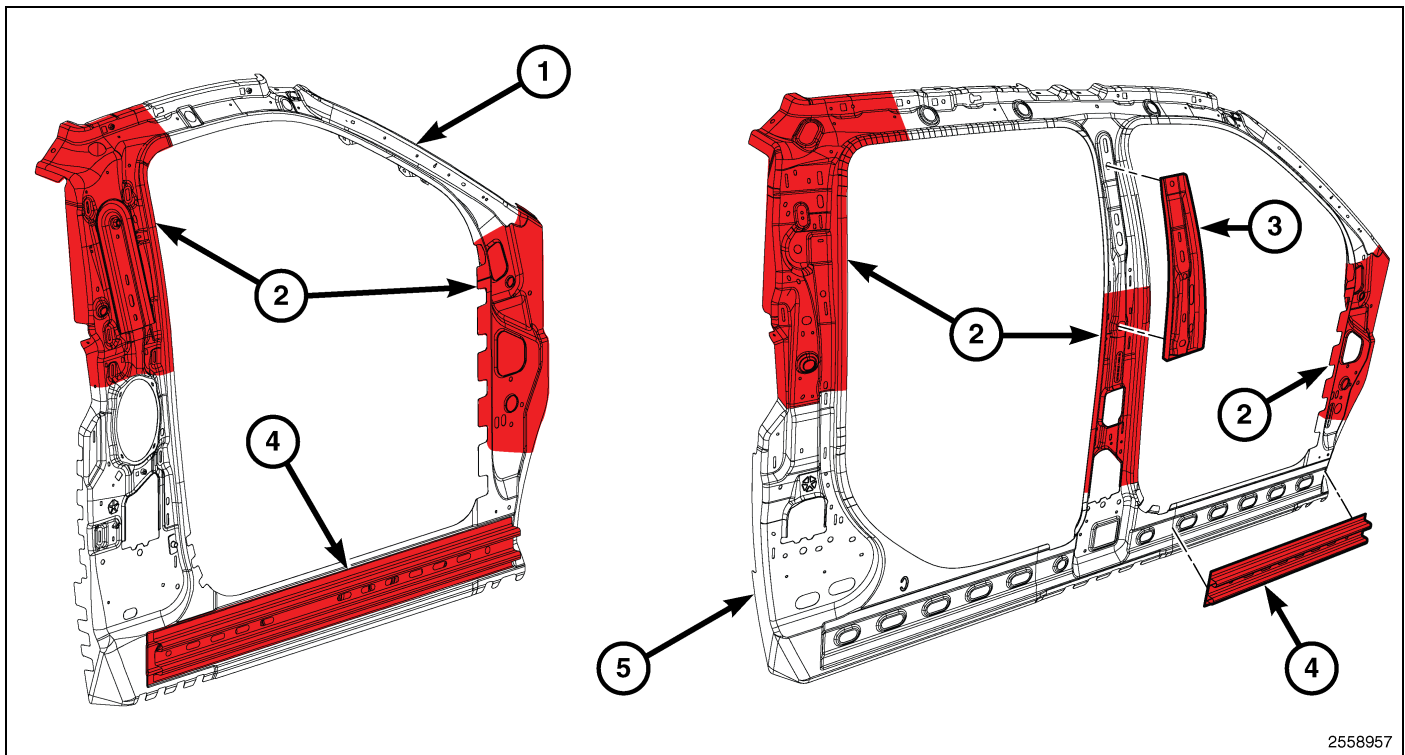

2558957

- 1 - STANDARD CAB
- 2 - **DO NOT SECTION THESE AREAS**
- 3 - REINFORCEMENT - SHOULDER MOUNT (**REMOVE BEFORE SECTIONING UPPER B-PILLAR**)
- 4 - FRAME REINFORCEMENT (**DO NOT SECTION THESE PARTS**)
- 5 - CREW CAB SHOWN, QUAD CAB SIMILAR

NOTE: Right side shown, left side similar.

The inner aperture should not be sectioned within 152.5 mm (6 in.) of the back glass opening, door striker, or door hinge locations. Further, the joint should whenever possible be performed in as "flat" an area as possible to simplify the repair. While the joint may include "holes" and formations, it is suggested they be avoided but where this is not possible, the technician must ensure that the additional material thickness does not impede installation of fasteners, etc. that the hole exists for.

The repair joint is a combination lap-joint (1) and butt-joint (2) – the panels are lapped in the flat areas and butted in contoured locations and at weld flanges. The graphic better illustrates this process.

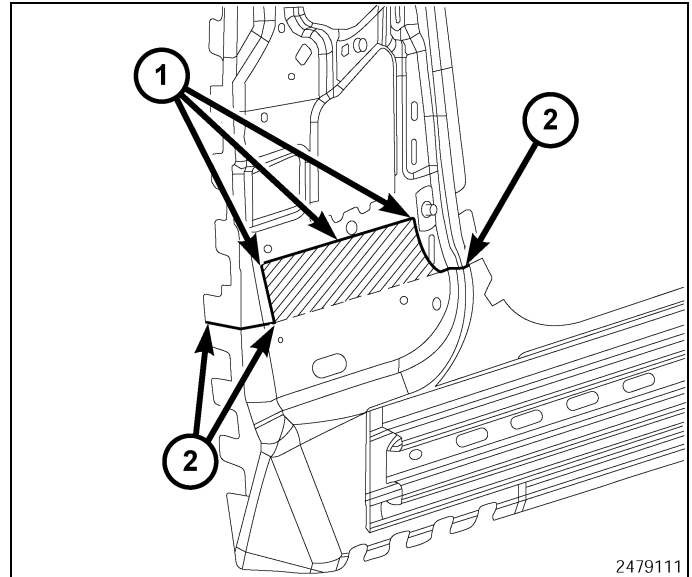

1 - LAP-JOINT WELDS

2 - BUTT-JOINT WELDS

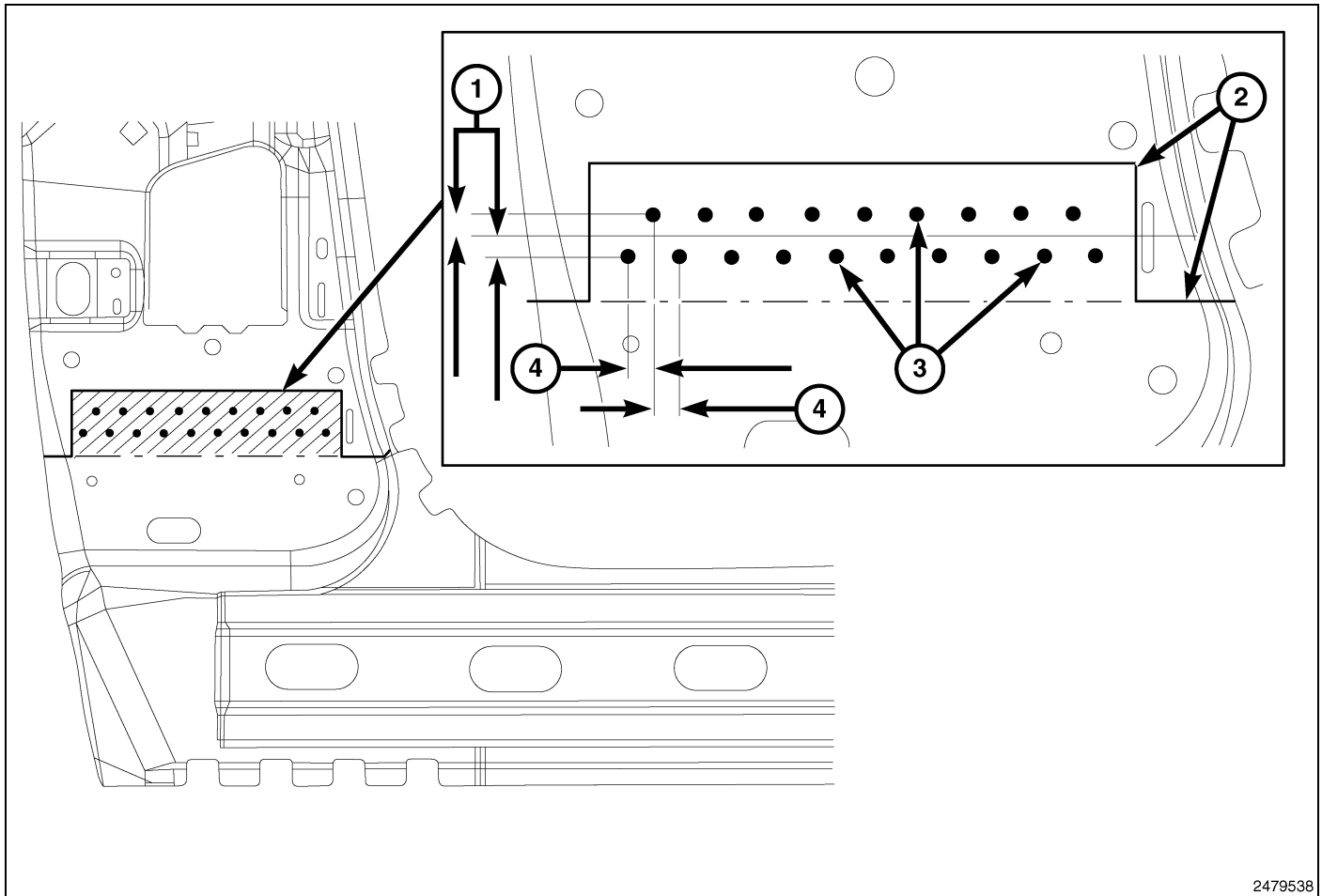

2479538

1 - 9.5 mm (0.375 in.)

2 - MIG SEAM WELD

3 - MIG PLUG WELDS

4 - 12.5 mm (0.5 in.)

In the lap-jointed area, staggered MIG plug welds are used to augment the joint and both edges of the lapped panels should be welded.

The MIG plug welds, or "puddle welds", should be made after drilling 8 mm (5/16 in) holes and should be staggered 12.5 mm (0.5 in.) apart following the centerline of the lap and should be alternating above and below the centerline 9.5 mm (0.375 in.).

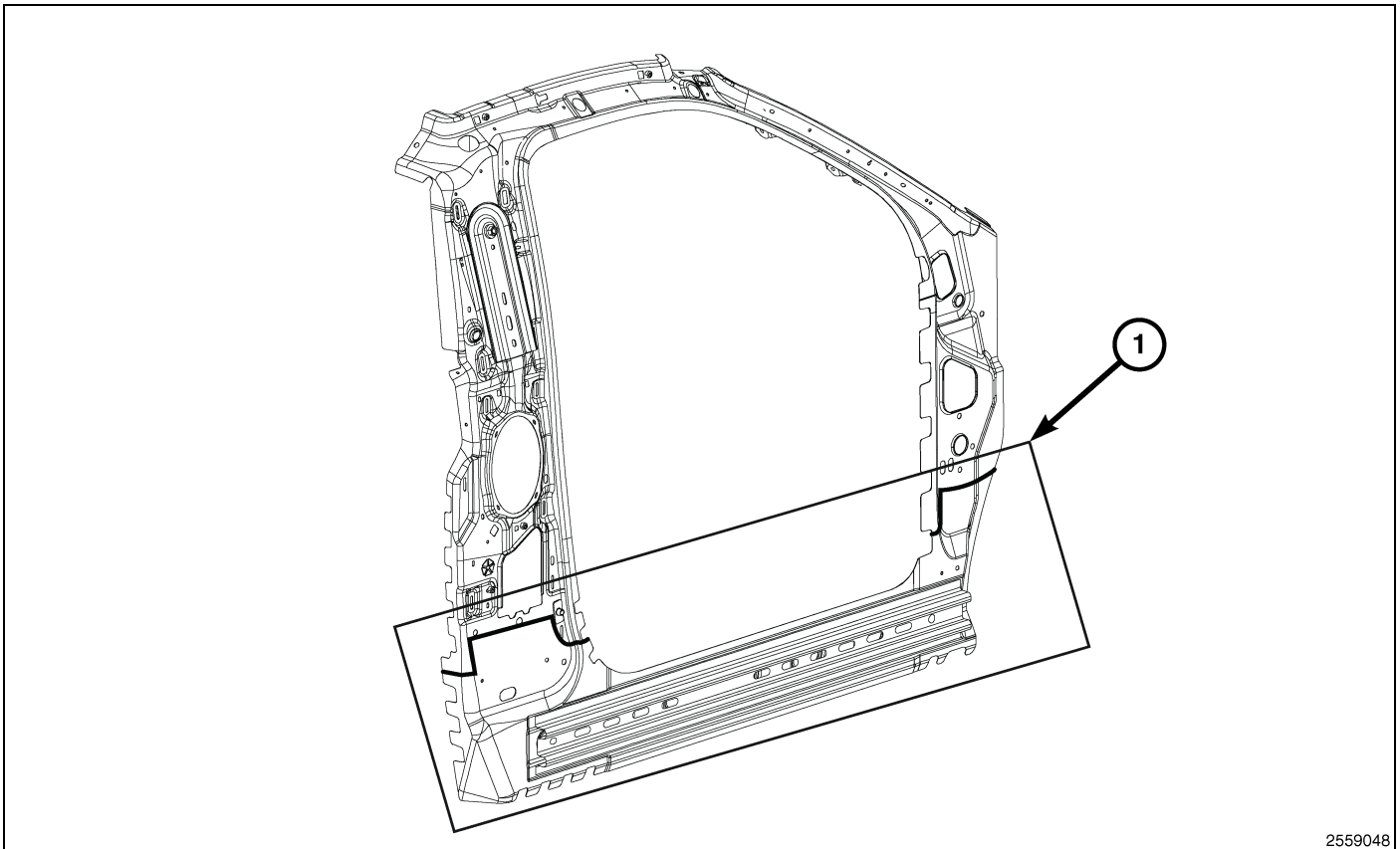

2559048

1 - CLEAN WELDS

CAUTION: Do not apply any corrosion protection to the weld zones until the outer panel is fully installed and all welding is completed as materials are flammable.

When all welding is completed, the welds should all be thoroughly cleaned.

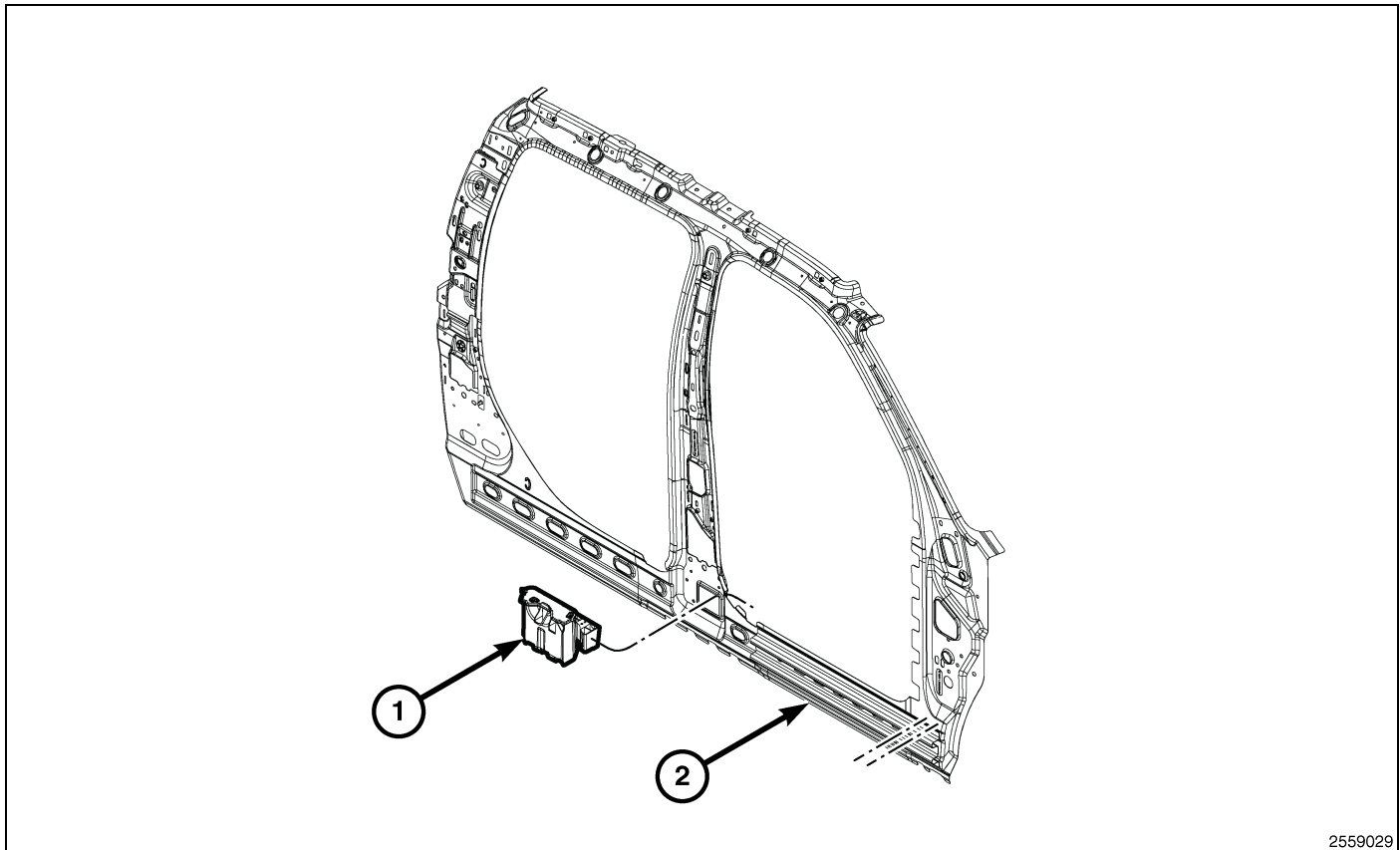

2559029

1 - B-PILLAR IMPACT BLOCK

2 - ROCKER REINFORCEMENT

When completing the remaining repair, make sure that any impact blocks (1) (base of the B-pillar) or rocker reinforcements (2) are installed before the outer panel is attached. The impact block in the base of the B-pillar is secured in production by an expandable coating which is activated during e-coating. Since the repair process cannot duplicate this, the block must be installed and secured between the panels to avoid an NVH issue. The impact block can be secured with either windshield urethane or structural adhesive applied liberally to ensure there is adequate contact.

As with any Chrysler repair, squeeze type resistance spot welding is the preferred method to duplicate OE welds whenever possible. All sealers at welded locations must provide corrosion protection and if uncertain whether the material is a sealer or adhesive, use an approved structural adhesive per the manufacturer's directions.

CAUTION: Use Mopar Cavity wax kit part # 68042969AA, or equivalent, AFTER all welding is complete as material is flammable.

After attachment of the outer panel is complete and all weld zones are thoroughly cleaned, apply corrosion protection Mopar Cavity wax kit part # 68042969AA, or equivalent, to the weld zones.

LIGHT DUTY FRONT FRAME RAIL TIP REPLACEMENT

CAUTION: This procedure is designed to replace the front frame rail tips that have been damaged in the crush initiator zones. Prior to any cutting, the vehicle must be mounted on the appropriate frame repair equipment ("frame rack"), checked with three dimensional measuring equipment, and the necessary pull corrections made without the use of heat. Refer to the Frame Dimension specifications section for more information.

- If damage remains in the frame beyond the area covered by this service part after the pull, the frame must be replaced in its entirety.
- If damage to the front body structure is evident, repair the Front End Sheet Metal (FESM) fender rails as necessary.
- Inspect all body mount bolts for damage and repair if necessary.

CAUTION: Inspect the spare tire winch assembly for damage. If any one or more of the following are evident, replace the winch assembly.

- Indications of cracked or bulging plastic.
- Housing flanges are bent or cracked.
- If winch was loose before repair.
- If the rivet heads are separated from the housing in any way.

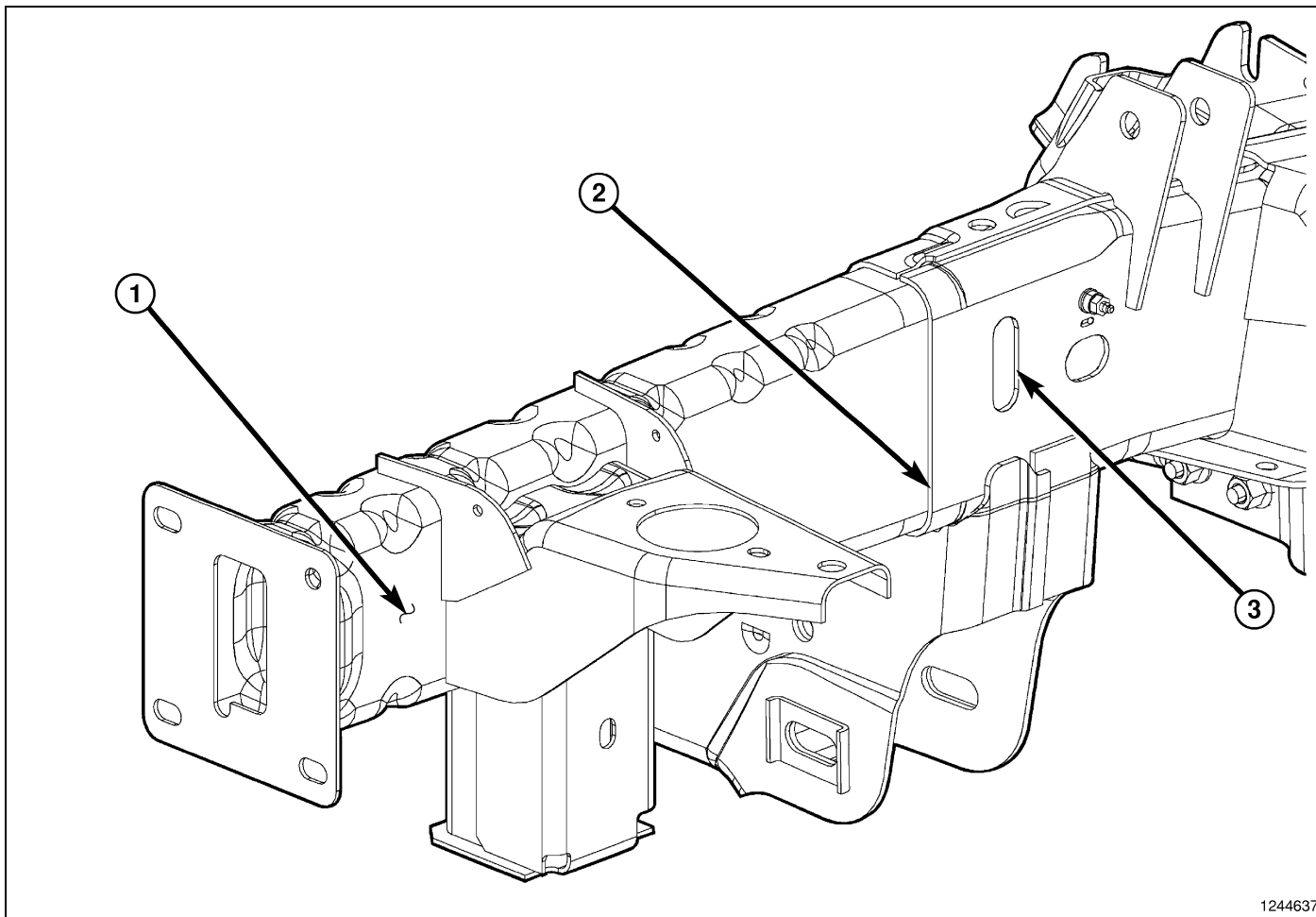

1244637

1. Before proceeding with this repair procedure review the required service warnings and precautions.
2. Remove all parts needed to gain access to the repair area. (Refer to appropriate Service Information - Removal Procedures.)

CAUTION: Do not use an oxy-acetylene cutting torch to remove the damaged frame rail tip. This is due to the inaccurate nature of the cut-line and the fact that the high temperatures achieved during flame cutting will change the metal characteristics and may weaken the frame and/or repair location.

3. Using a plasma cutter, reciprocating saw, or equivalent tool, carefully cut and remove the damaged frame rail tip (1). Cut at the forward edge of the weld at the tip to frame joint (2), do not cut the main frame rail.
4. Using a plasma cutter, or die grinder, remove the puddle weld (3) that attaches the frame tip to the frame rail.

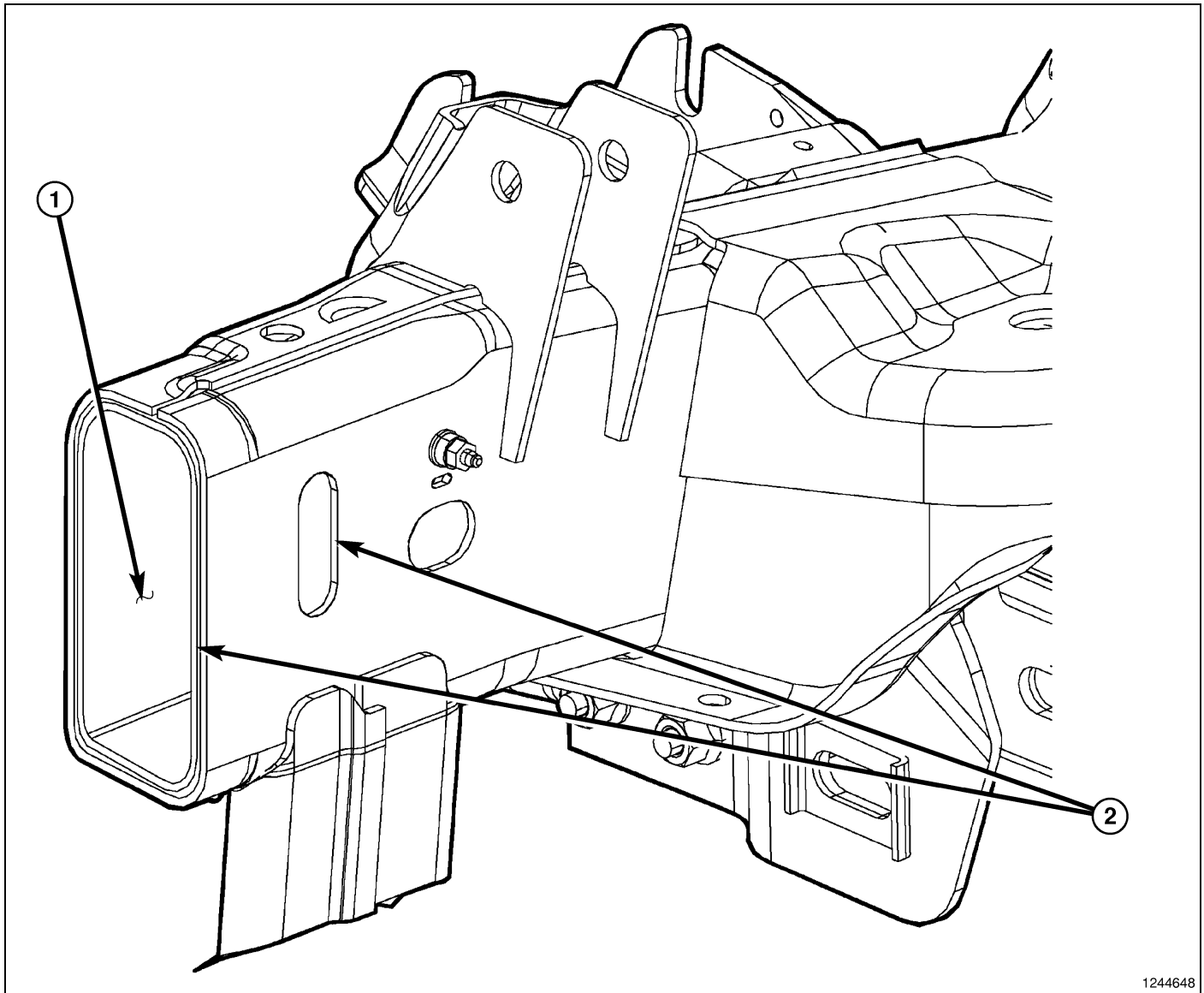

1244648

5. With the puddle weld removed, grind any remaining weld and remove the remaining piece of the frame tip (1) from within the frame rail and discard.
6. Smooth and square the cut edges of the original frame.
7. Remove any burrs at the hole and frame edge (2).

CAUTION: Shield the surrounding area and components from exposure to the welding spatter and heat.

8. Dry fit the new rail to verify alignment and make any adjustments as necessary.
9. Remove all internal and external OEM e-coat within 25 mm (1.0 in.) of the weld joint on the replacement tip and the existing frame rail.
10. Using the appropriate measuring equipment, verify the front end sheet metal bracket's location and adjust if required. (Refer to the frame dimension specifications section.)
11. When correctly aligned, tack weld the new rail tip into place.
12. Confirm that the alignment of the replacement frame rail tip is within specifications. (Refer to the frame dimension specifications section.)

13. Apply MIG plug weld (3) into the MIG plug weld hole on the replacement frame tip.
14. Start the MIG plug welds at location (1) and follow around the circumference of the MIG plug weld hole and end weld overlapping start point (2).

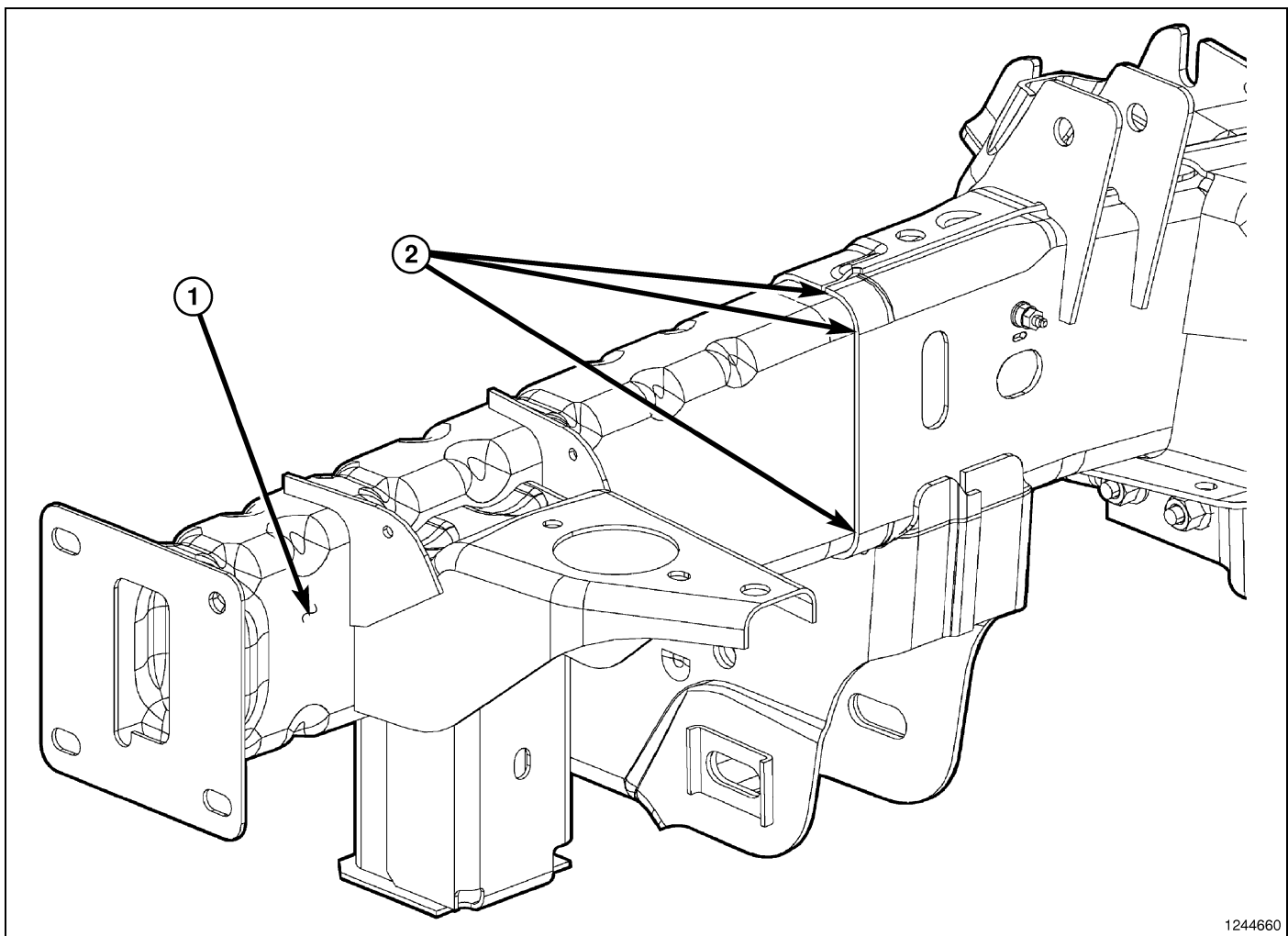
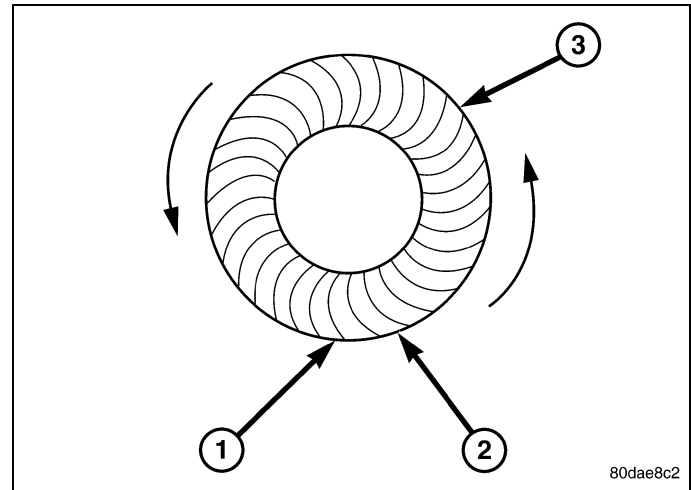

15. The weld at the tip to frame joint (2) should be performed in a skip (stitch) type method to minimize the heat buildup and frame distortion, utilizing the Weld Process Specifications. The preferred method is GMAW (MIG).
16. Weld the joint, one quadrant at a time, switching to the opposite side of the frame rail for each quadrant.
17. Confirm alignment of the replacement frame rail tip (1). (Refer to the frame dimension specifications section.)

NOTE: Any burned surface coatings will need to be removed prior to application of corrosion preventative coatings.

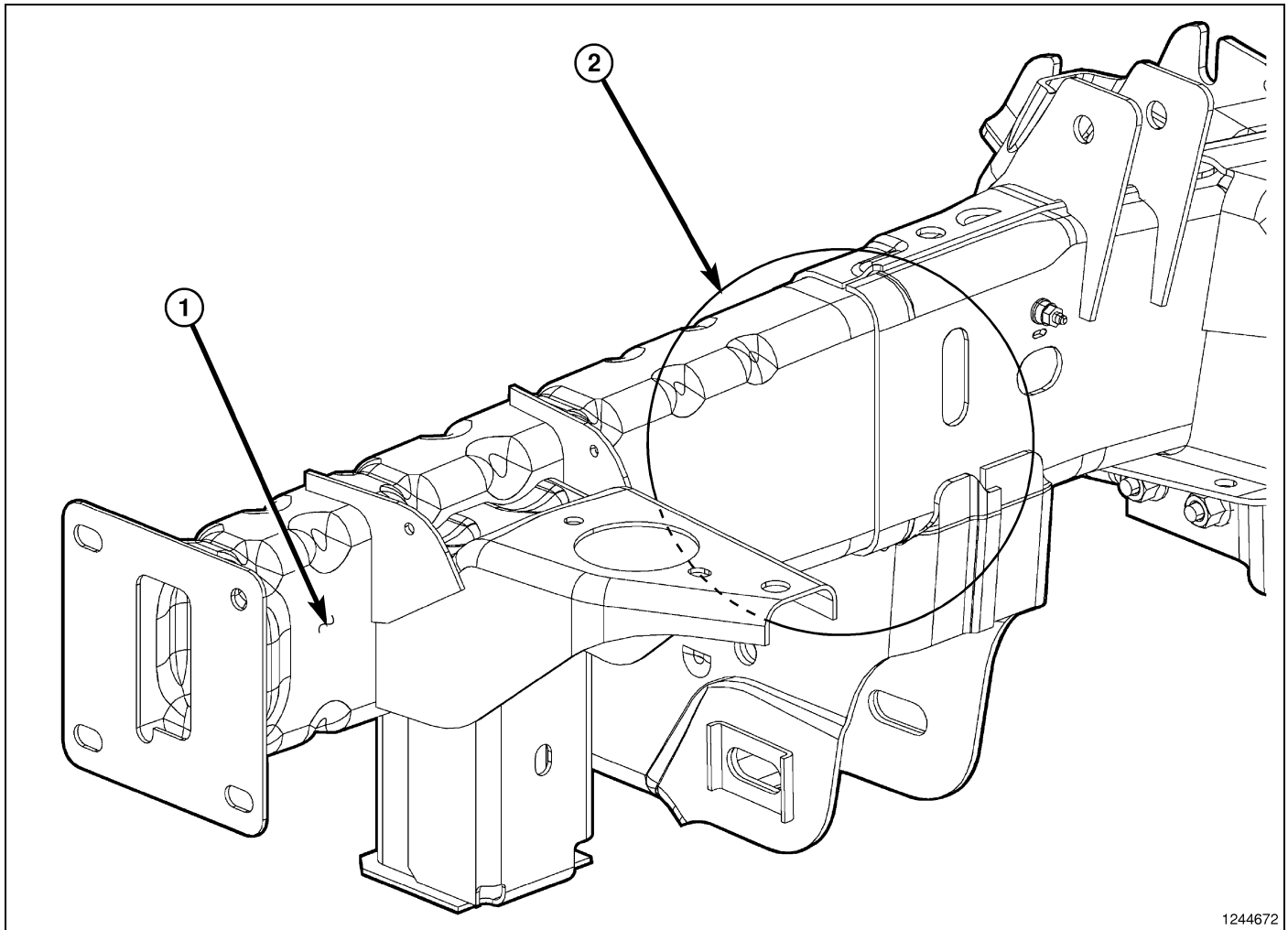

1244672

NOTE: Using Mopar Cavity wax kit (part # 68042969AA) / Undercoating kit (part # 68042967AA) or equivalent.

18. Dress the welded area (2) and apply corrosion resistant coatings inside and out.
 - a. Apply epoxy primer to the inside of the frame rail repair area.
 - b. Inside the rail, inject a creeping wax based rust inhibitor compound through the existing holes in the frame ensuring 100% coverage including the space between the original frame rail and the replacement rail tip (1) using Mopar Cavity wax kit (part # 68042969AA) / Undercoating kit (part # 68042967AA) or equivalent.
 - c. Apply a durable top coat to the outside of the repair area (2).
19. Complete other repairs.
20. Install all removed parts. (Refer to appropriate Service Information – Installation Procedures.)

HYDROFORM FENDER RAIL REPAIR

CAUTION: This repair procedure assumes damage to the right or left hydroform fender rail (1). Prior to any repairs, the vehicle must be mounted on the appropriate frame repair equipment (“frame rack”), checked with three dimensional measuring equipment, and necessary pull corrections made. If damage exists in the hydroform fender rail, or cab beyond the area covered by this service procedure after dimensional corrections are made, the hydroform must be replaced in its entirety.

CAUTION: Inspect the tire winch assembly for damage. If any one or more of the following are evident, replace the winch assembly.

- Indications of cracked or bulging plastic.
- Housing flanges are bent or cracked.
- If winch was loose before repair.
- If the rivet heads are separated from the housing in any way.

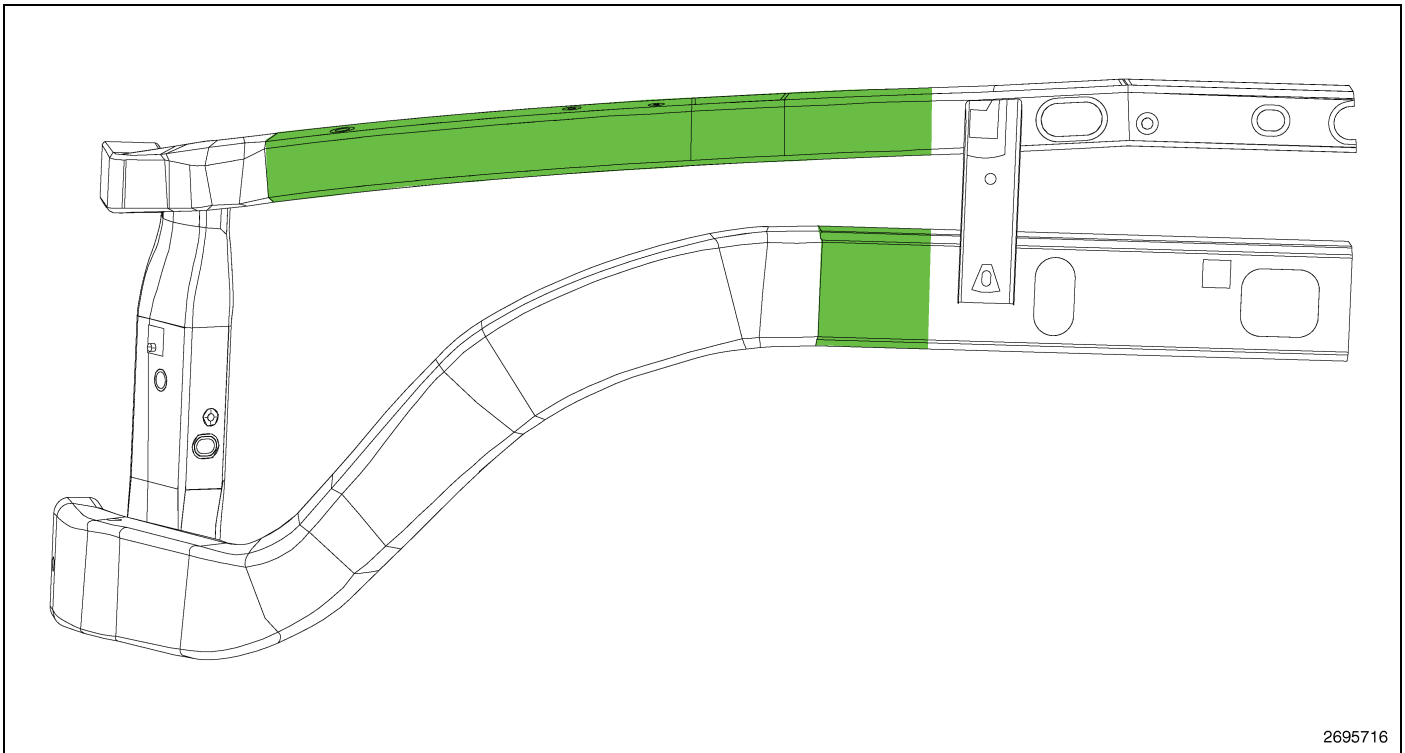

1. Before proceeding with this repair procedure review the required service warnings and precautions.
2. Remove all parts needed to gain access to the repair area. (Refer to appropriate Service Information - Removal Procedures.)
3. Disconnect and isolate the battery negative cable.

CAUTION: Do not use any flame or plasma cutting equipment to cut the frame in this procedure. The inaccurate and high temperatures achieved during flame or plasma cutting will change the metal characteristics and may weaken the frame and/or repair location.

4. Using a reciprocating saw or equivalent, cut the fender rail and shotgun at a straight and square section of the hydroform and remove.
5. Smooth and square the cut edges.
6. Using the damaged structure as a reference cut the service part at the same location as the first cut. Smooth and square the cut edges.

NOTE: The repair structure should butt up to the remaining structure and provide the same overall vehicle geometry.

7. Fabricate 51 mm (2.0 in.) long repair inserts using scrap from the old structure or the replacement part. It will be necessary to split the inserts on each of their four sides to fit into the hydroform.
8. Remove any paint or e-coat from the inserts and also to the interior and exterior of the hydroforms.
9. Cut plug weld holes as described below.
 - On the upper rail, cut one 13 mm (0.5 in.) hole on each side of the rail, 25 mm (1.0 in.) from the butt joint of the tubes.
 - On the lower rail, cut one 13 mm (0.5 in.) hole on the top and bottom sides of the rail 25 mm (1.0 in.) from the butt joint of the tube.
 - On the lower rail, cut two 13 mm (0.5 in.) holes on the inner and outer sides of the rail 25 mm (1.0 in.) from the butt joint of the tube.

CAUTION: Shield the surrounding area and components from exposure to the welding spatter and heat.

10. Install the insert 1" into the replacement part and tack into place with a weld.

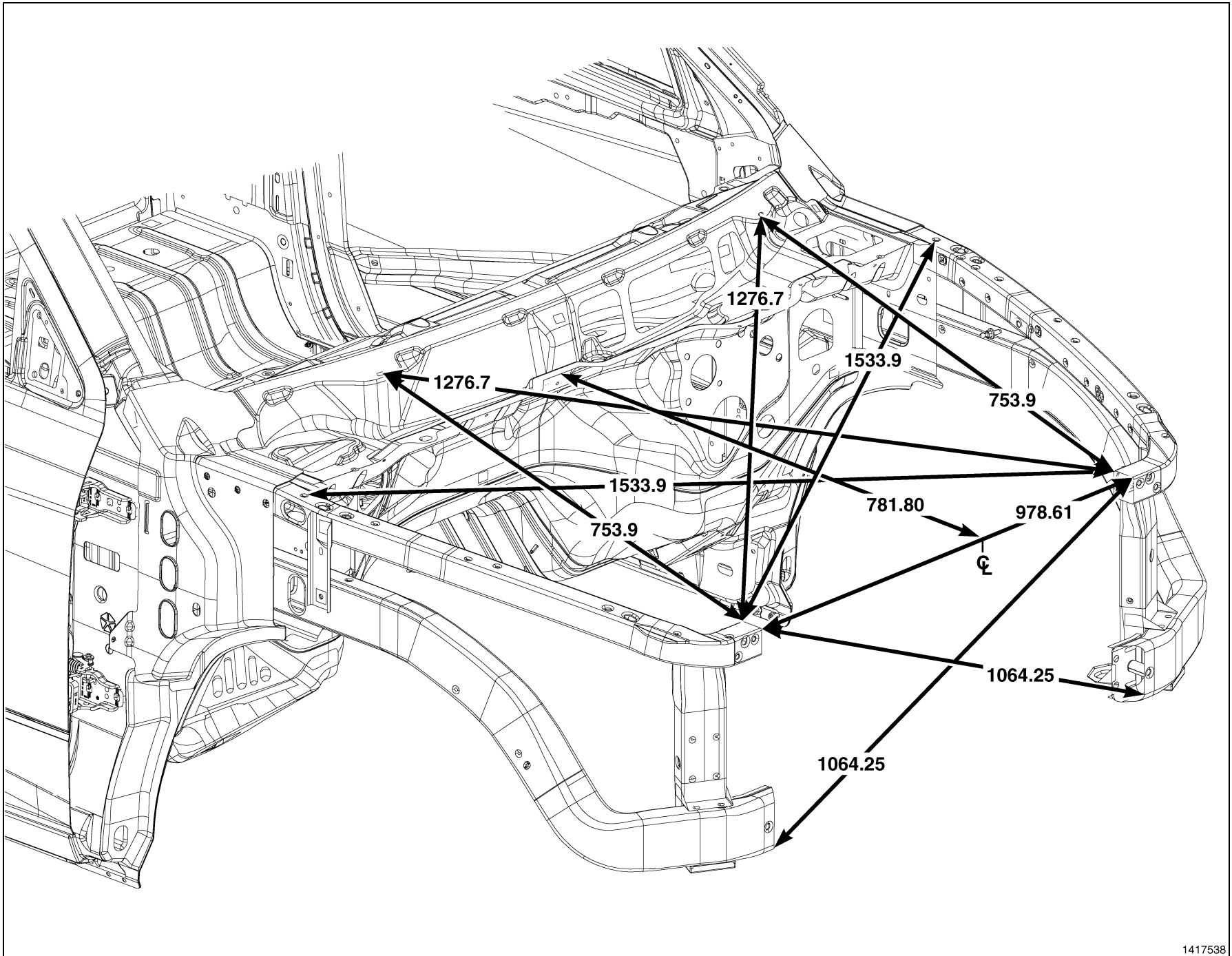

1417538

Fig. 30 Engine Compartment/Body Structure

11. Insert the service part into place and using the appropriate measuring equipment, verify the front end sheet metal bracket's location in all three (X,Y, and Z) planes of space.
12. Complete all 360° plug welds.

NOTE: Before the final welding, use three dimensional measuring equipment to ensure the part is in the correct location. Verify that tap plate extrusion at the bottom of the vertical post lines up with the isolator and hole in the frame perch mount. Also ensure the lower radiator closure tube is bolted into the forward shotgun ends.

13. Complete welding by making a 360° butt weld around the fender rails.
14. Metal finish the exposed welds on the hydroforms.
15. Dress the welded area and apply corrosion resistant coatings inside and out.
 - a. Inside the rail, inject a creeping wax based rust inhibitor compound to the inside of the hydroforms ensuring 100% coverage including the mating face between the fender rail sections and insert such that corrosion protection is restored in the internal cavity.
 - b. Apply a durable top coat to the outside of the repair area.
16. Complete other repairs.
17. Install all removed parts. (Refer to appropriate Service Information – Installation Procedures.)
18. Reconnect the battery negative cable.

CORROSION PROTECTION

Corrosion Protection Restoration

"Corrosion protection" encompasses all the materials and coatings which protect a vehicle from corrosion and include:

- Coated steels
- E-coat primer on the complete body
- Body sealing to eliminate water and air intrusion where panels join
- Structural adhesives in some joints
- Chip resistant primer applications on the entire body
- Paint application
- Underbody corrosion protection
- Inner panel corrosion protection added to repair areas

Corrosion protection must be restored during a repair anytime it may have been compromised. All areas that have been subjected to structural pulls, clamping, straightening, welding, or any other any other operation that may have imparted damage to the corrosion protection system will need to be addressed.

In the repair process corrosion protection is addressed in three phases: pre-refinish, refinish and post-refinish.

Pre-refinish

In the pre-finish phase, structural adhesives, seam sealers and other applied coatings are installed. Sheet metal seams are sealed to prevent water intrusion into the "dry" areas of the vehicle, such as passenger compartment, and also to prevent intrusions of contaminants, such as water and road salt, into seams causing corrosion. Lap joints, hem flanges, and any panel mating locations need to be addressed during the repair and treated to duplicate the original vehicle build.

All bare metal should be etch primed prior to applying seam sealer, following the refinish material provider's instructions for doing so, unless the manufacture of the sealer specifically states otherwise.

When working around pinch weld flanges, seam sealer should be installed to duplicate the original appearance and function. If it is unclear whether the original sealing material **between** the flanges is strictly a sealer or structural adhesive, always default to a structural adhesive such as Mopar part #05083855AA, Fusor 112B, or 3M 08116. Refer to the welding and joining section of the Body Repair Manual for additional information related to weld-bonding and welding around adhesives and sealers.

Roof and closure panels will require the use of Anti-Flutter foam. Where inner panel supports meet external panels, the proper replacement materials in these areas are Mopar part #04864015AB, or equivalent, or Fusor 121, or 3M 04274 (NVH dampening material).

All hem flanges on closure panels should be sealed whether sealer is apparent or not. This includes those disturbed during the repair, and those on new replacement panels. Either duplicate the existing bead in shape or size, or where one is not obvious, seal the hem flange in a discrete fashion. Hem flanges should be sealed using Mopar part #04318026, Fusor 129, or 3M 08308.

Lap joints, such as in floor pans, should be sealed to duplicate the sealer visible, but also addressed on any exterior surface by sealing the lap weather visible or not.

NOTE: Chrysler does not recommend the use of any type of "weld-thru" primer during repairs. Weld-bonding with corrosion protecting adhesives or sealers, along with final application of inner panel corrosion protection is the proper method.

Refinish

All painted surfaces should be coated using a Chrysler group LLC approved refinish material. The refinish process includes application of undercoats, primers (filler & sealer), basecoats and clearcoat. These approved materials have been tested to the same material standards as the production materials.

Post-refinish

All new panels, and repair areas, must have inner panel corrosion protection applied after the painting operation is complete, but before all the trim is reinstalled. Mopar Cavity Wax #68042970AA, or 3M Rustfighter #08891 should be applied to all interior cavities, weld flanges, hem flanges as well as any are affected by the repair especially where any type of welding was performed. Inner panel corrosion protection should be applied using "pressure pot" equipment with wands which provide 360-degree material coverage for closed cavities, and directional spray wands for visible coverage (Mopar kit #04271235). Additionally, the corrosion protecting material must be applied in two coats with a minimum 30-minute flash time between applications.

Wheel wells and underbody panels which have been involved in the repair process should also have a final undercoating applied. Use Mopar #05093417AA, or equivalent, and apply with "pressure pot" style application equipment.

Any disturbed or removed NVH foam needs to be replaced. Use Mopar part #05142864AA, Fusor 130, or 3M 8463.

Following this arrangement, choice of materials, and proper application, the repaired vehicle should be as well protected against corrosion as it was prior to the repair.

Material Locations

SEALERS AND SOUND DEADENERS

Terminology

Work Time : The length of time a sealer can continue to be applied or tooled effectively.

Set Time : Time when there is no longer product transfer.

Handling Time : The time when a part can be safely transported and sealer can no longer be tooled or repositioned.

Full Cure Time : Time when a sealer has reached it's full strength.

Paintable Time : Established time when refinish materials can safely be applied to a sealer.

Sealers

Brushable : Single component sealer applied with a brush.

Flowable : Sealer with low viscosity and self-leveling characteristics.

Pumpable : A two component or one component sealer that seals interior and exterior joints and voids.

Resistance Weld-through : Sealer / adhesive that can be used in conjunction with resistance spot welding.

Sealer Tape : Preformed sealer.

Sprayable : Sealer applied with a pneumatic dispenser to duplicate original textured appearance.

Thumb Grade : Heavy bodied sealer for sealing large gaps and filling voids. Should remain soft and pliable.

Sound Deadeners

Non-structural Flexible Acoustical : Flexible foam with sealing and sound deadening properties.

Non-Structural Ridged Acoustical : Ridged foam with sealing and sound deadening properties.

Mastic Pads : Sound deadener pad that is preformed to fit a specific area.

Identifying Sealers

Several types of sealers and sound deadeners are used during assembly. Therefore, specific applications may not be identified in this publication. General applications and the various types of products for repair will be featured to identify and replace OEM sealers and sound deadeners.

Helpful Sealer Tips

- Check shelf life or expiration date prior to beginning sealer applications.

- Be sure "work time" is appropriate for sealer application.
- Temperature, humidity and thickness of sealer will affect the work, set and paintable times.
- Test fit replacement panels prior to installation to insure tight fit and proper seal.
- Equalize 2K Products according to adhesive manufacturer's recommendations.
- Always follow manufacturer's recommendations for storage, usage and application to achieve best performance of the product.

SOUND DEADENER LOCATIONS

DESCRIPTION	FIGURE
HOOD	(Fig. 31)
DASH PANEL (1 OF 2)	(Fig. 32)
DASH PANEL (2 OF 2)	(Fig. 33)
COWL	(Fig. 34)
FLOOR PAN TUNNEL	(Fig. 35)
FRONT FLOOR PAN	(Fig. 36)
REAR FLOOR PAN – STANDARD CAB	(Fig. 37)
REAR FLOOR PAN – QUAD CAB	(Fig. 38)
REAR FLOOR PAN – CREW CAB	(Fig. 39)
FRONT DOORS	(Fig. 40)
OUTER BODY SIDE – QUAD CAB	(Fig. 41)
CAB BACK	(Fig. 42)
ROOF – STANDARD CAB	(Fig. 43)
ROOF – QUAD CAB	(Fig. 44)
ROOF – CREW CAB	(Fig. 45)

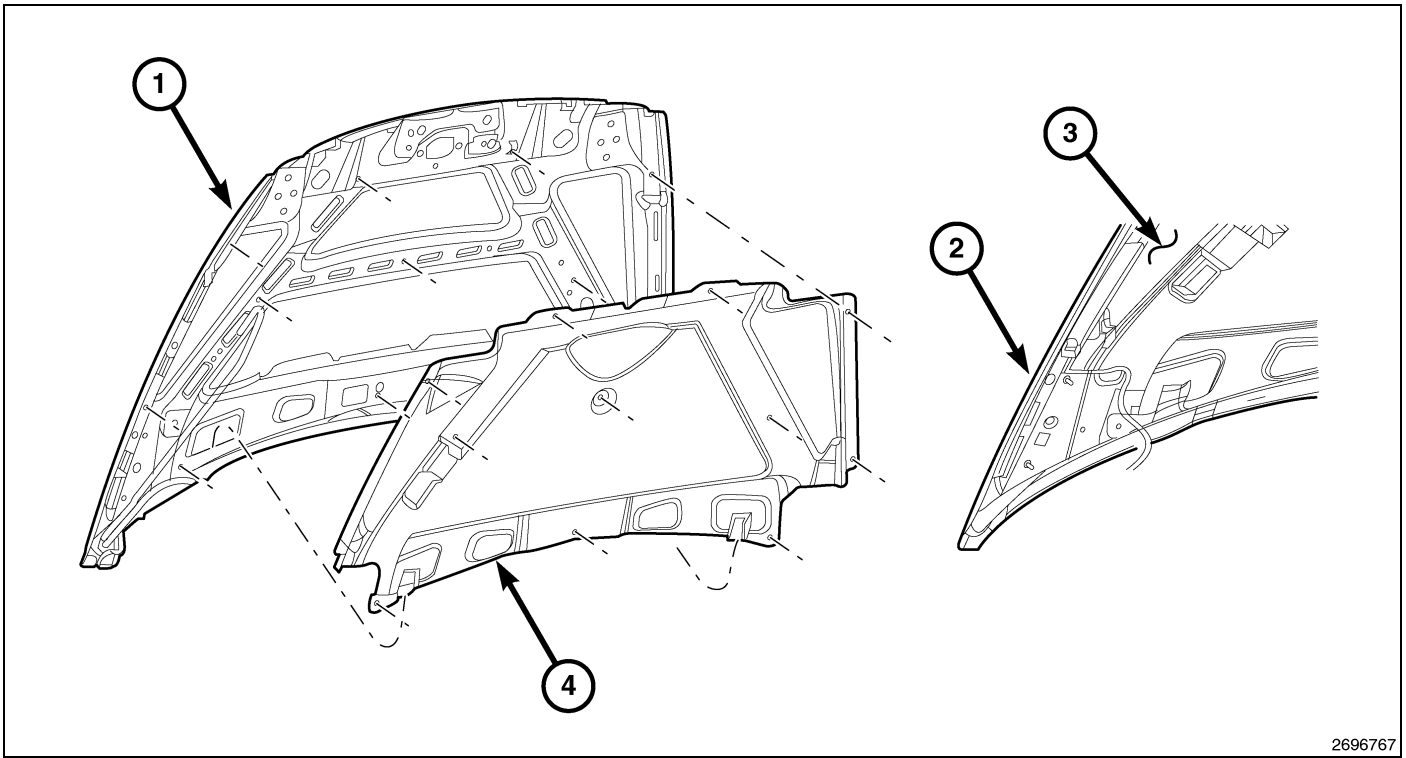

2696767

Fig. 31 HOOD

- 1 - HOOD
- 2 - HOOD
- 3 - HOOD SILENCER PAD
- 4 - HOOD SILENCER PAD

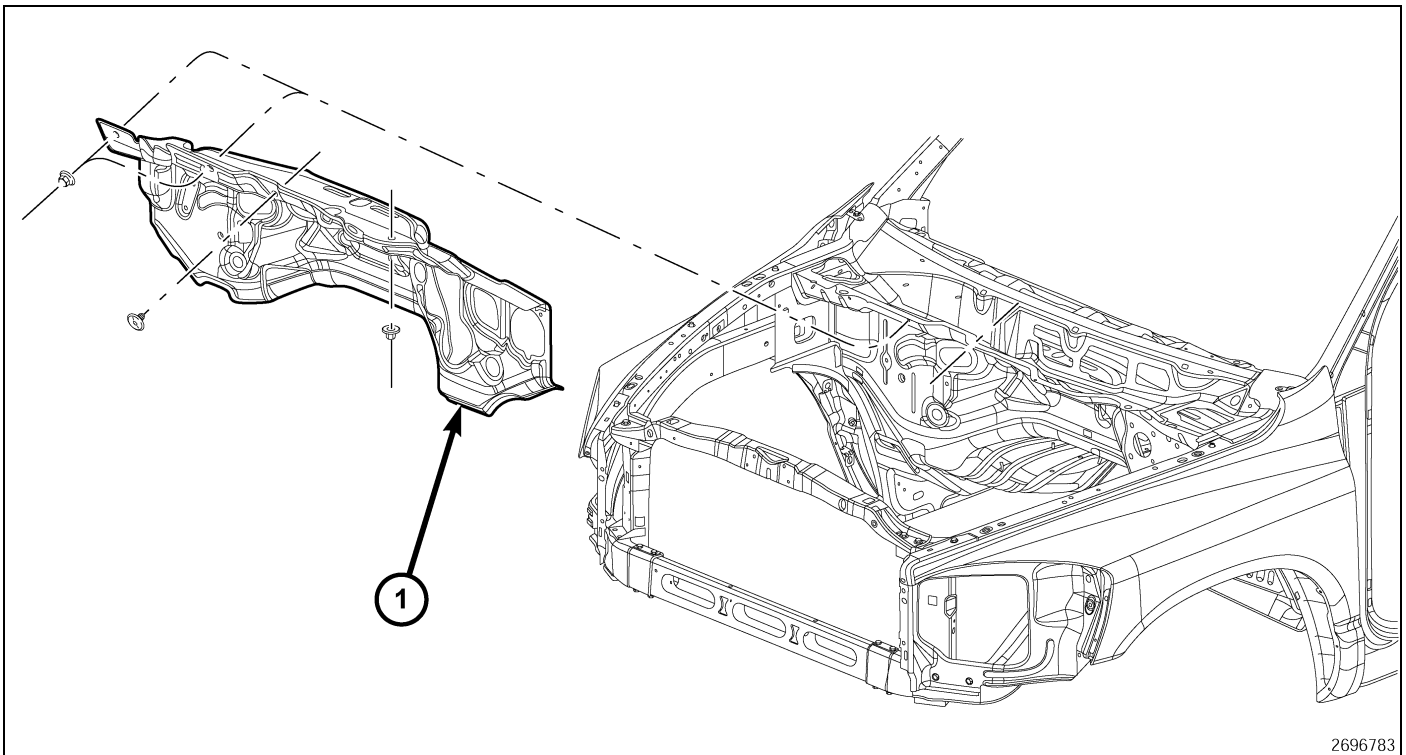

2696783

Fig. 32 DASH PANEL (1 OF 2)

- 1 - DASH PANEL SILENCER PAD

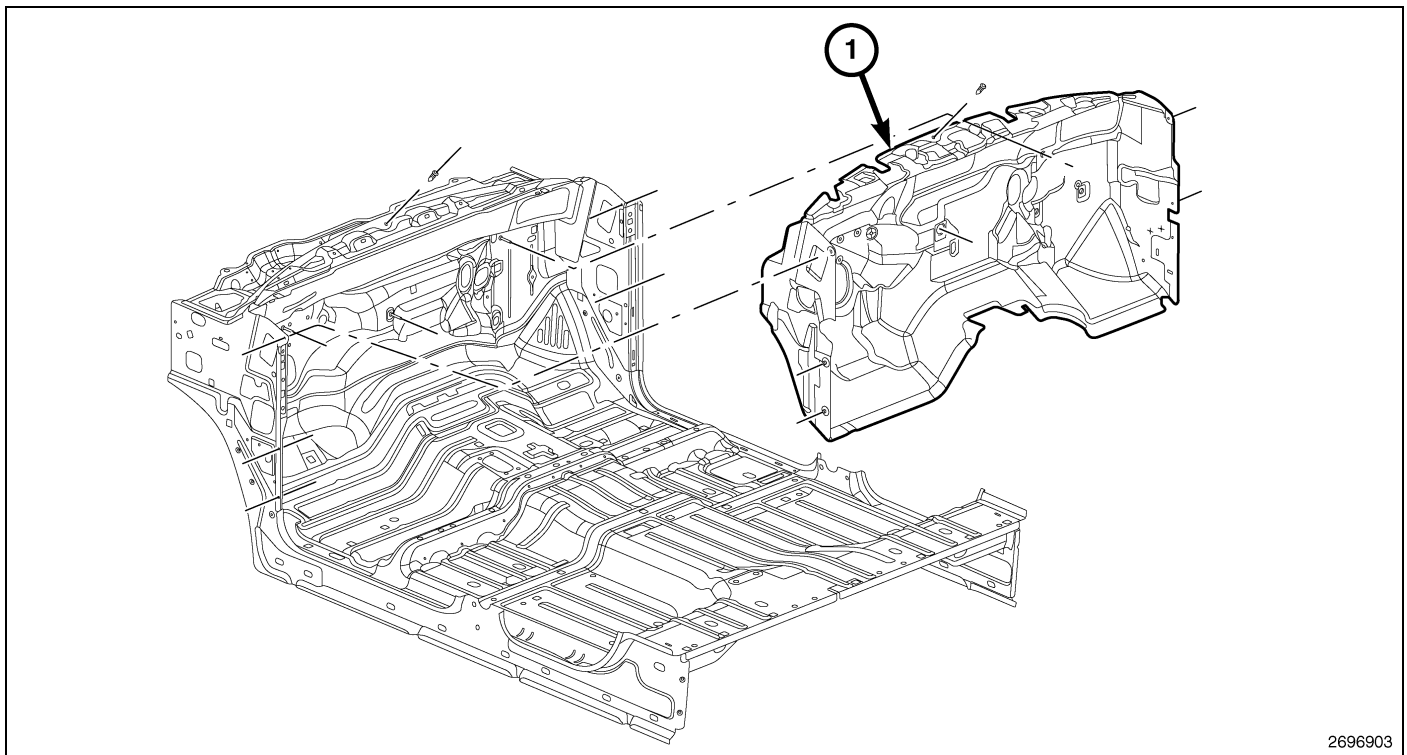

2696903

Fig. 33 DASH PANEL (2 OF 2)**NOTE: Quad cab shown, standard and crew cabs typical**

1 - DASH PANEL SILENCER PAD

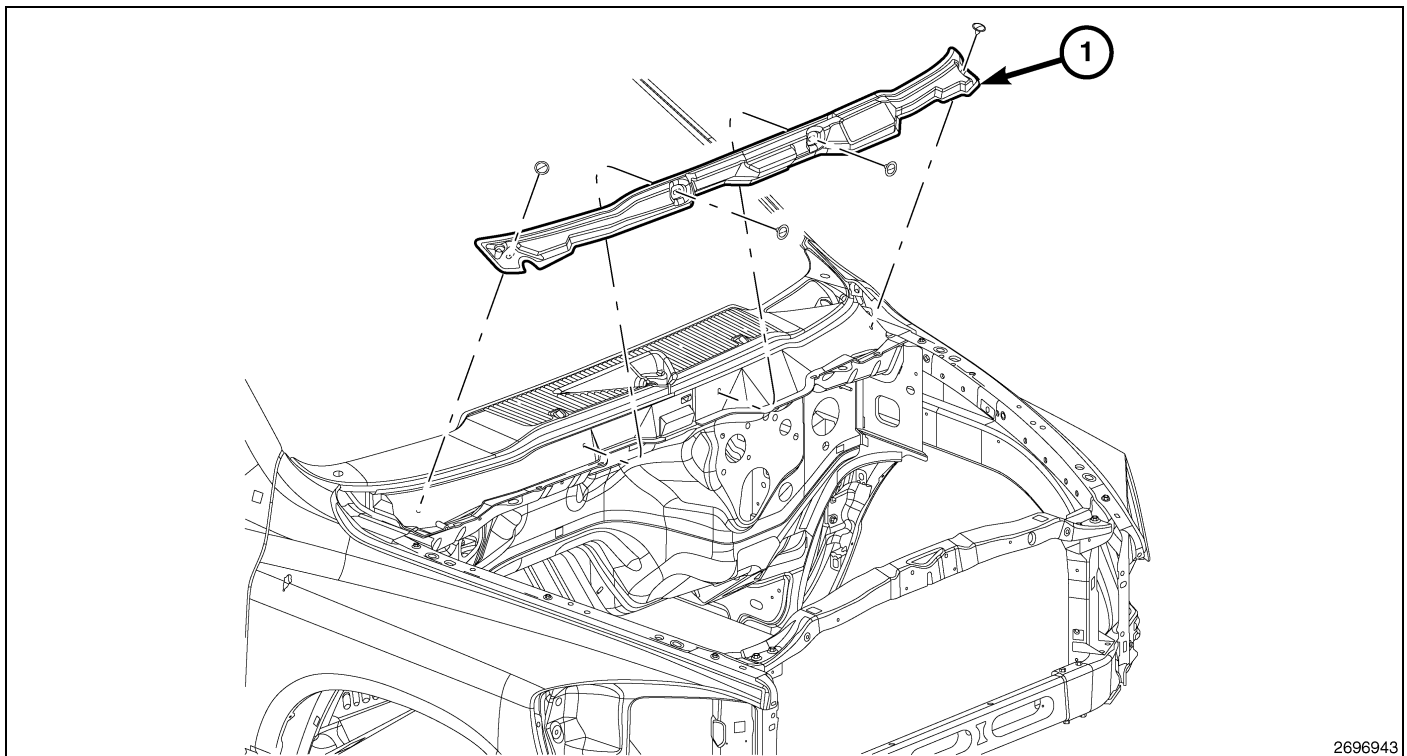

2696943

Fig. 34 COWL

1 - COWL SCREEN SILENCER PAD

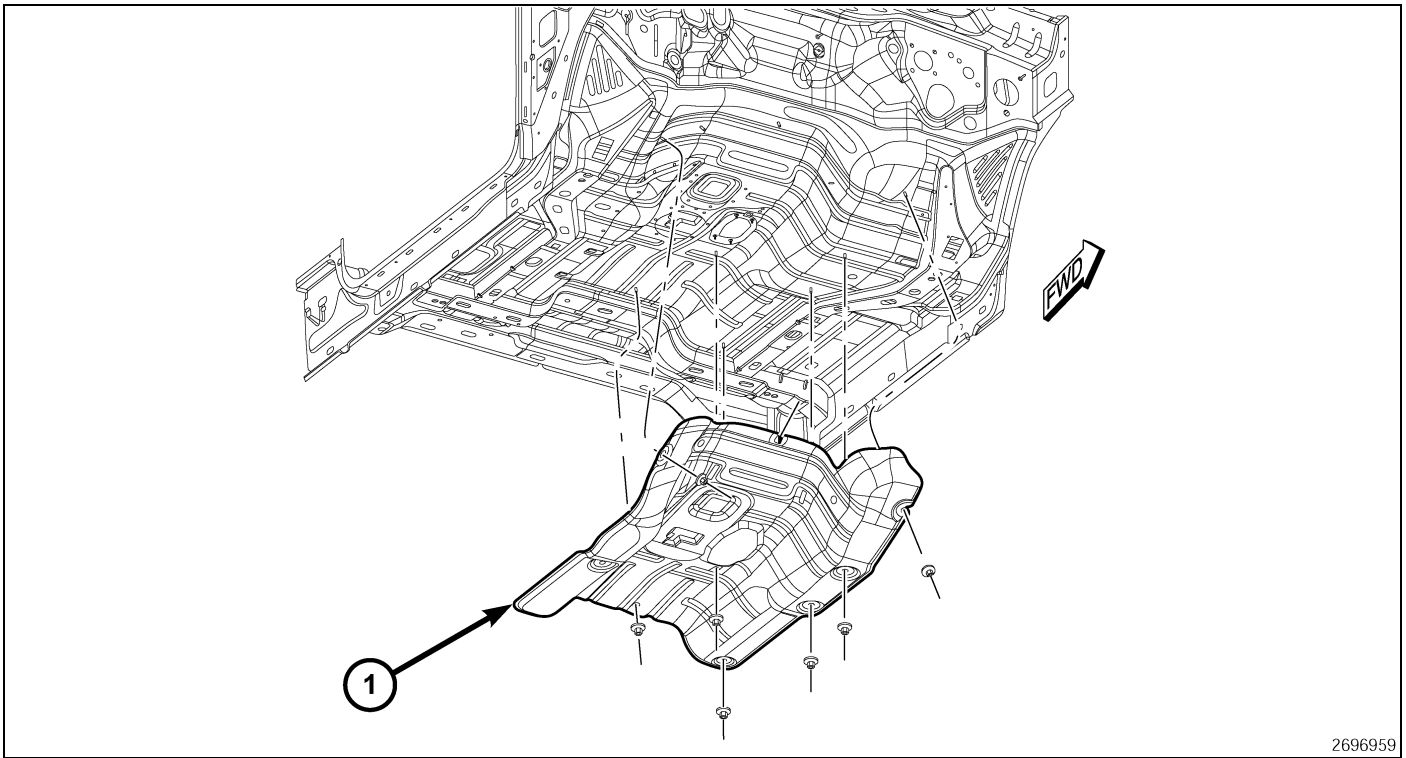

2696959

Fig. 35 FLOOR PAN TUNNEL

NOTE: Standard cab shown, quad and mega cabs similar

1 - FLOOR PAN TUNNEL SILENCER PAD

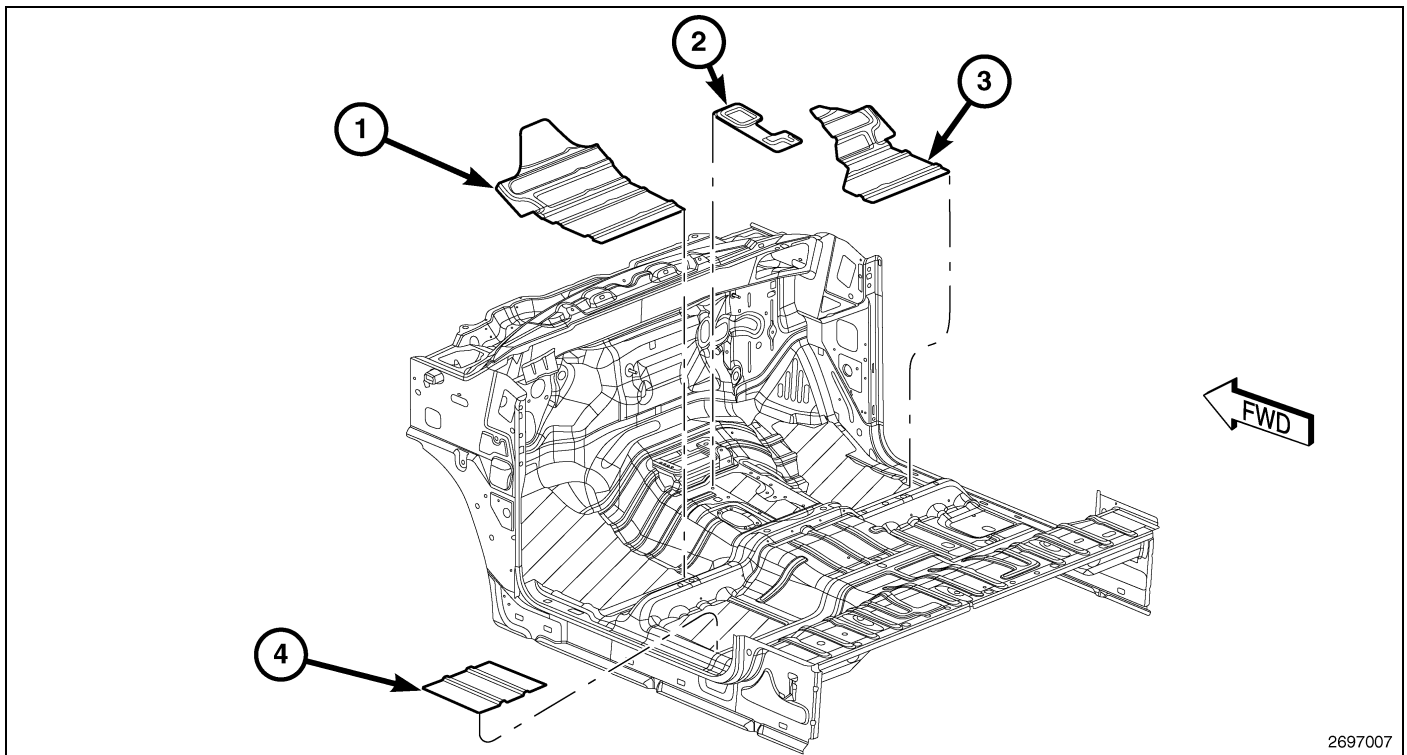
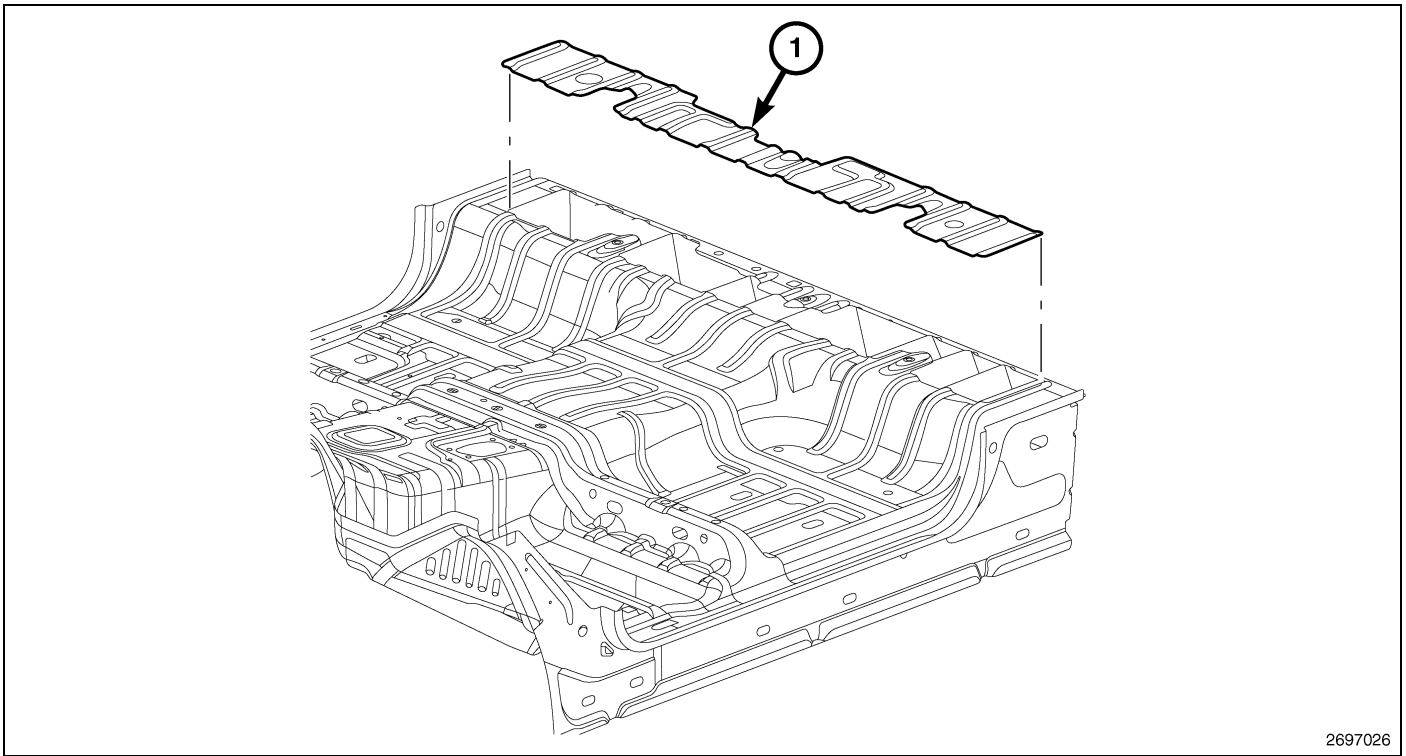

Fig. 36 FRONT FLOOR PAN

NOTE: Standard cab shown, quad and crew cabs typical.

- 1 - LEFT FRONT FLOOR PAN SOUND DEADENER PAD
- 2 - FRONT FLOOR PAN TUNNEL SOUND DEADENER PAD
- 3 - RIGHT FRONT FLOOR PAN SOUND DEADENER PAD
- 4 - LEFT FRONT FLOOR PAN UNDER SEAT SOUND DEADENER PAD



2697026

Fig. 37 REAR FLOOR PAN – STANDARD CAB

1 - REAR FLOOR PAN SOUND DEADENER

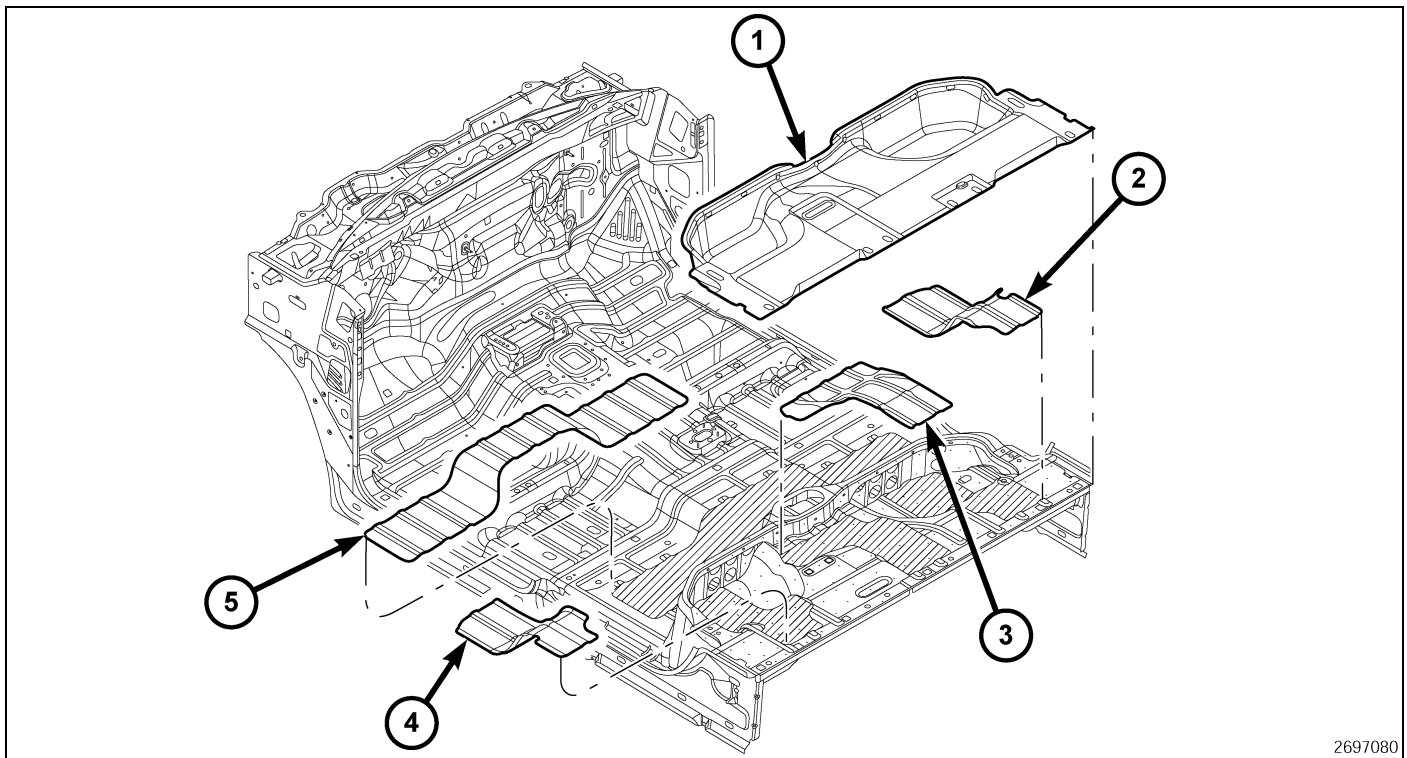
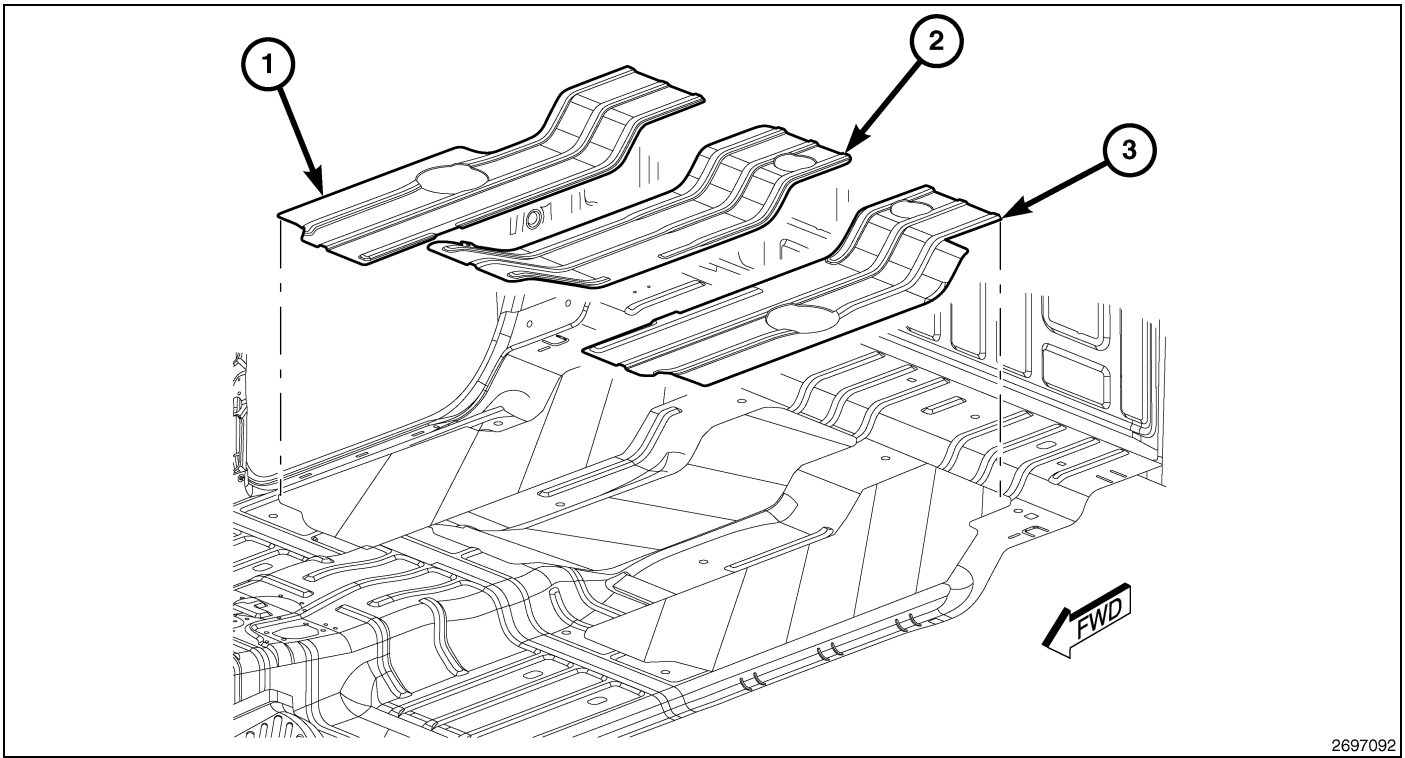

Fig. 38 REAR FLOOR PAN – QUAD CAB

- 1 - REAR BIN SILENCER
- 2 - RIGHT REAR FLOOR PAN SOUND DEADENER PAD
- 3 - CENTER REAR FLOOR PAN SOUND DEADENER PAD
- 4 - LEFT REAR FLOOR PAN SOUND DEADENER PAD
- 5 - REAR FRONT FLOOR PAN SOUND DEADENER PAD



2697092

Fig. 39 REAR FLOOR PAN – CREW CAB

- 1 - RIGHT REAR FLOOR PAN SOUND DEADENER PAD
- 2 - CENTER FLOOR PAN SOUND DEADENER PAD
- 3 - LEFT REAR FLOOR PAN SOUND DEADENER PAD

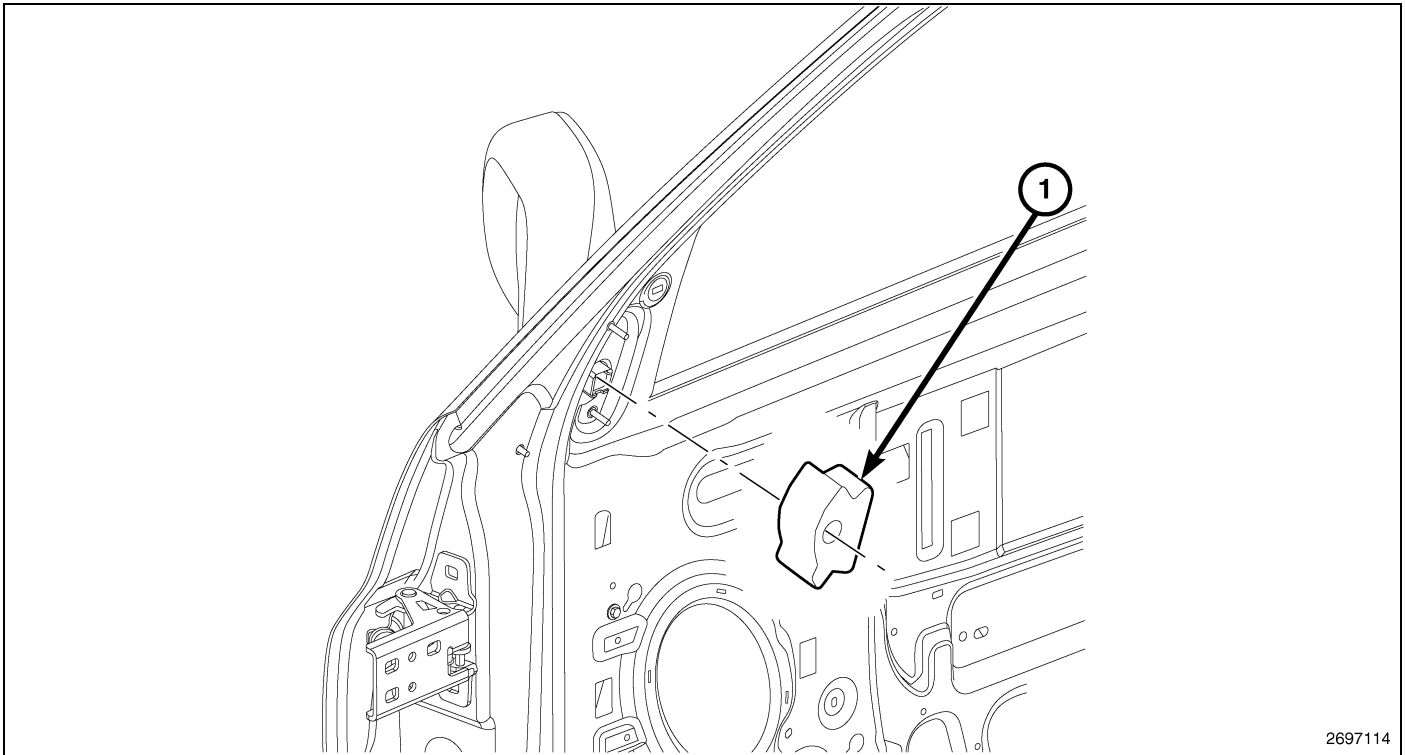

2697114

Fig. 40 FRONT DOORS

- 1 - MIRROR FLAG FOAM PAD

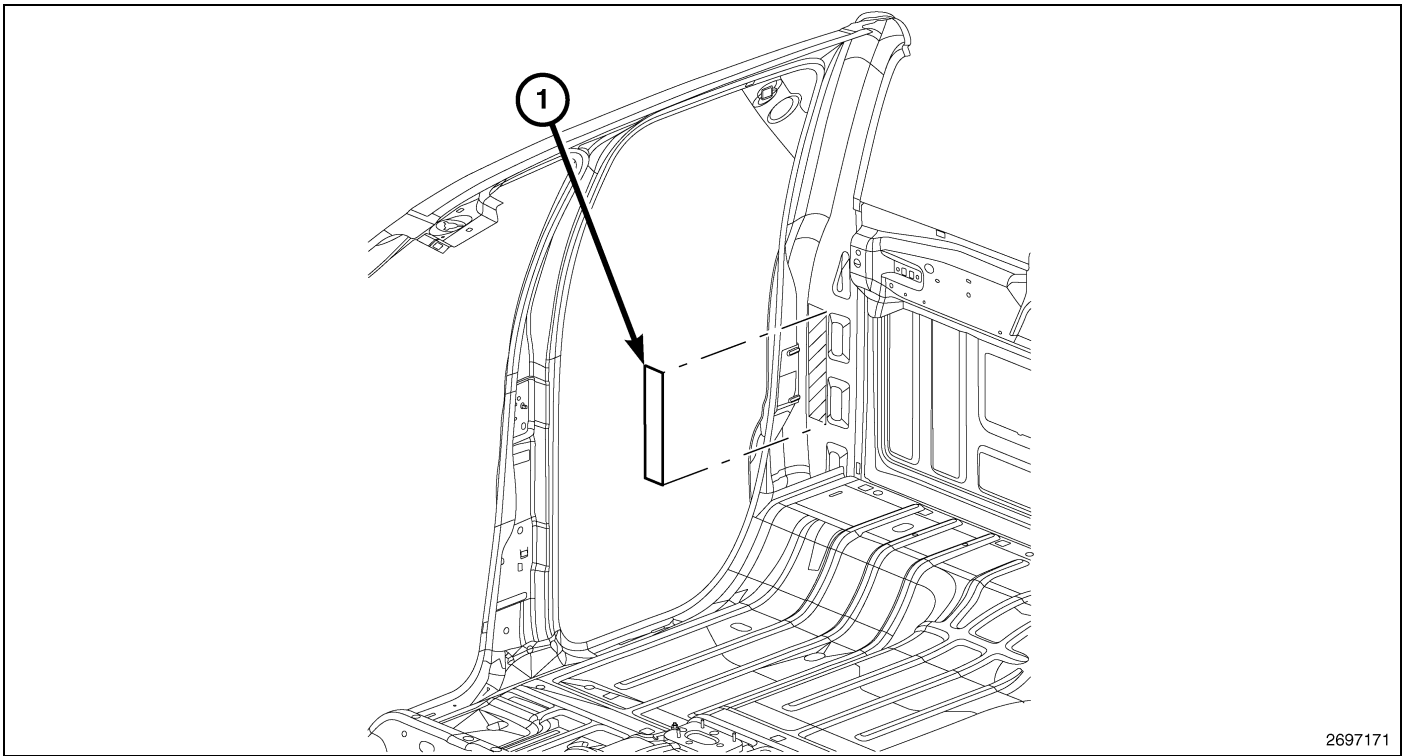

2697171

Fig. 41 OUTER BODY SIDE – QUAD CAB

NOTE: Right side shown, left side typical.

Collision Information SIDE OUTER/FRONT EXTENSION PANEL SOUND DEADENER PAD

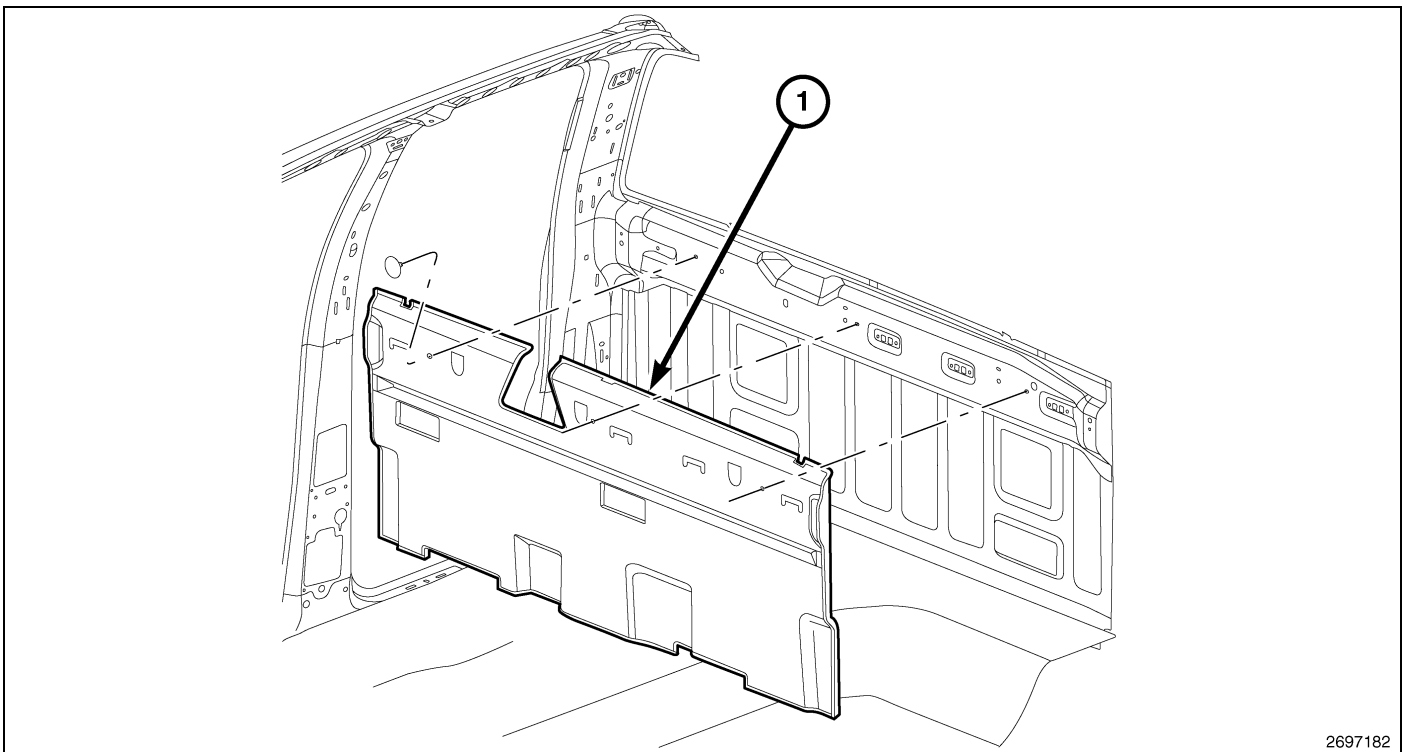

2697182

Fig. 42 CAB BACK

NOTE: Quad cab shown, standard and crew cabs typical

1 - CAB BACK PANEL SILENCER PAD

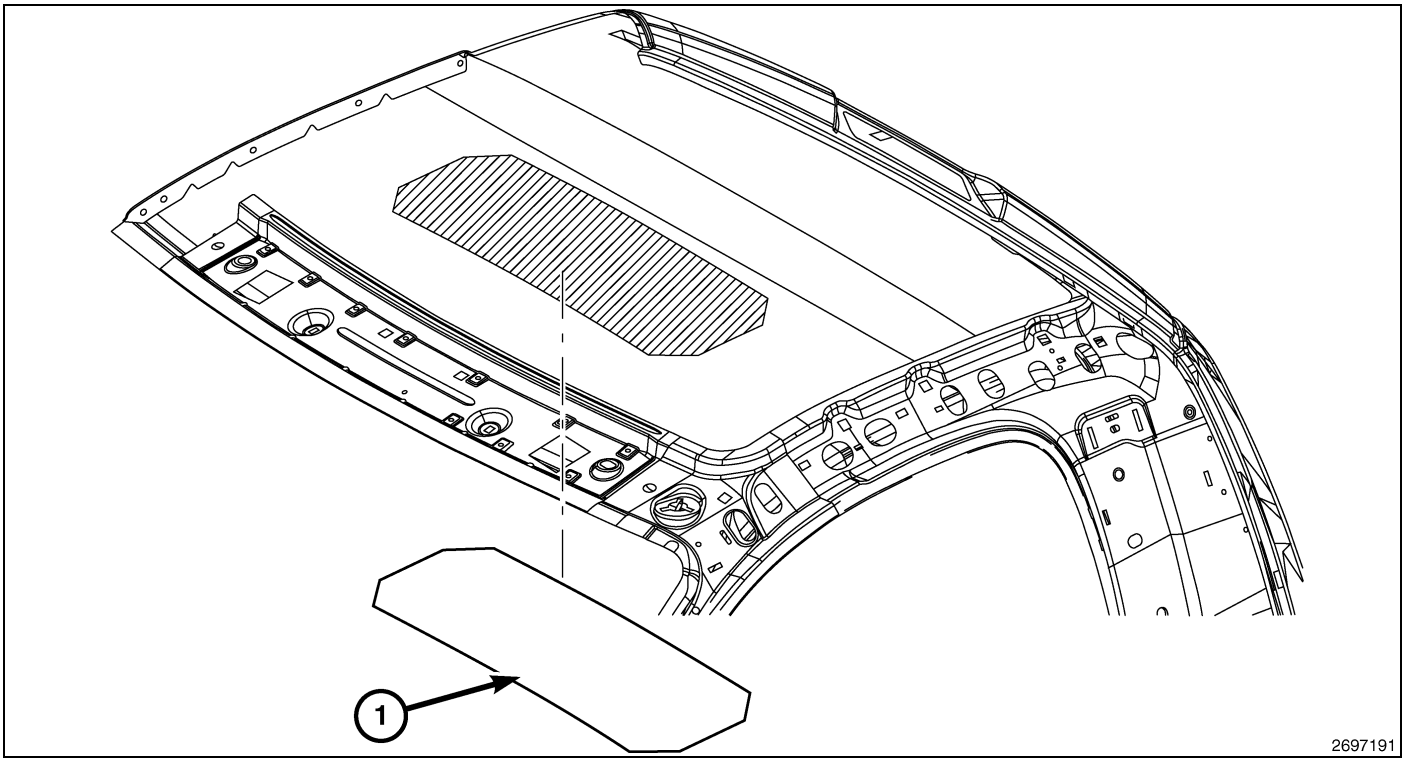

2697191

Fig. 43 ROOF – STANDARD CAB

1 - ROOF PANEL SOUND DEADENER PAD

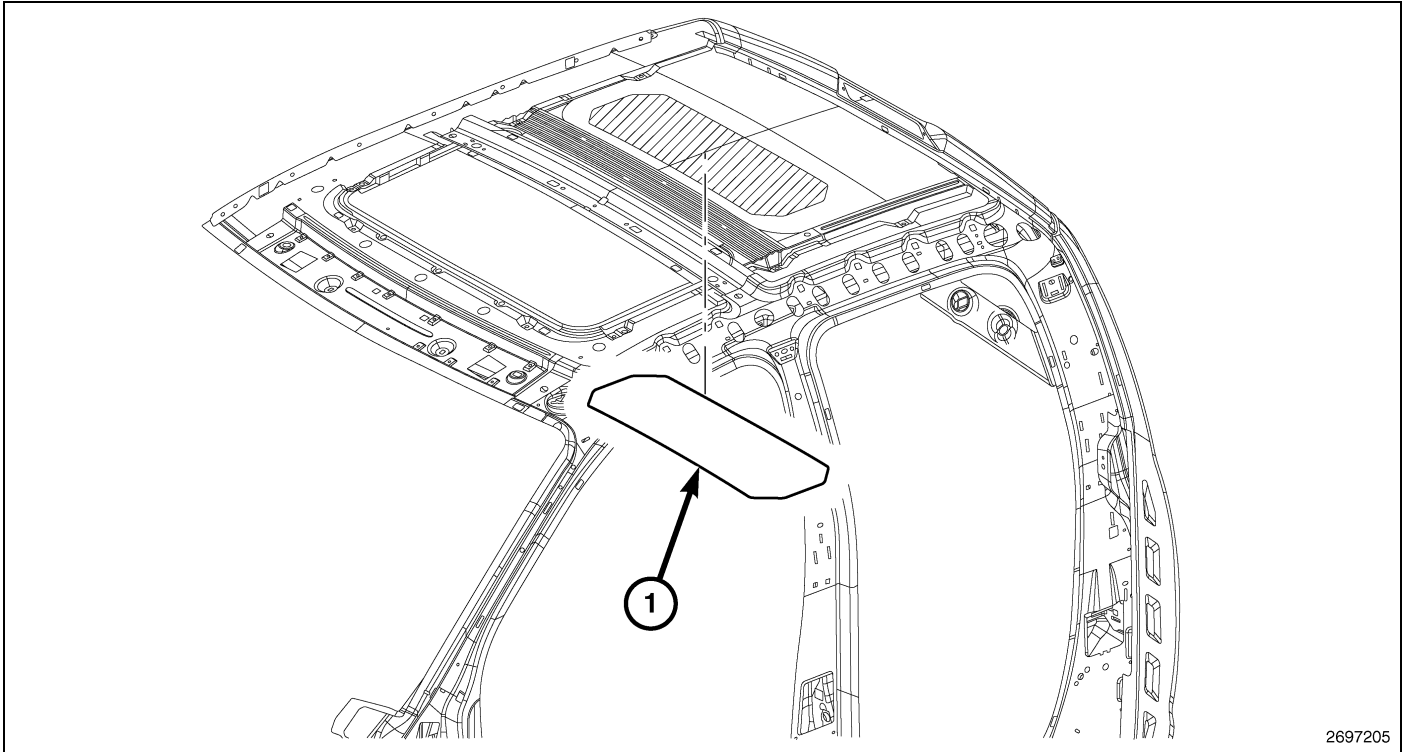

2697205

Fig. 44 ROOF – QUAD CAB

1 - ROOF PANEL SOUND DEADENER PAD

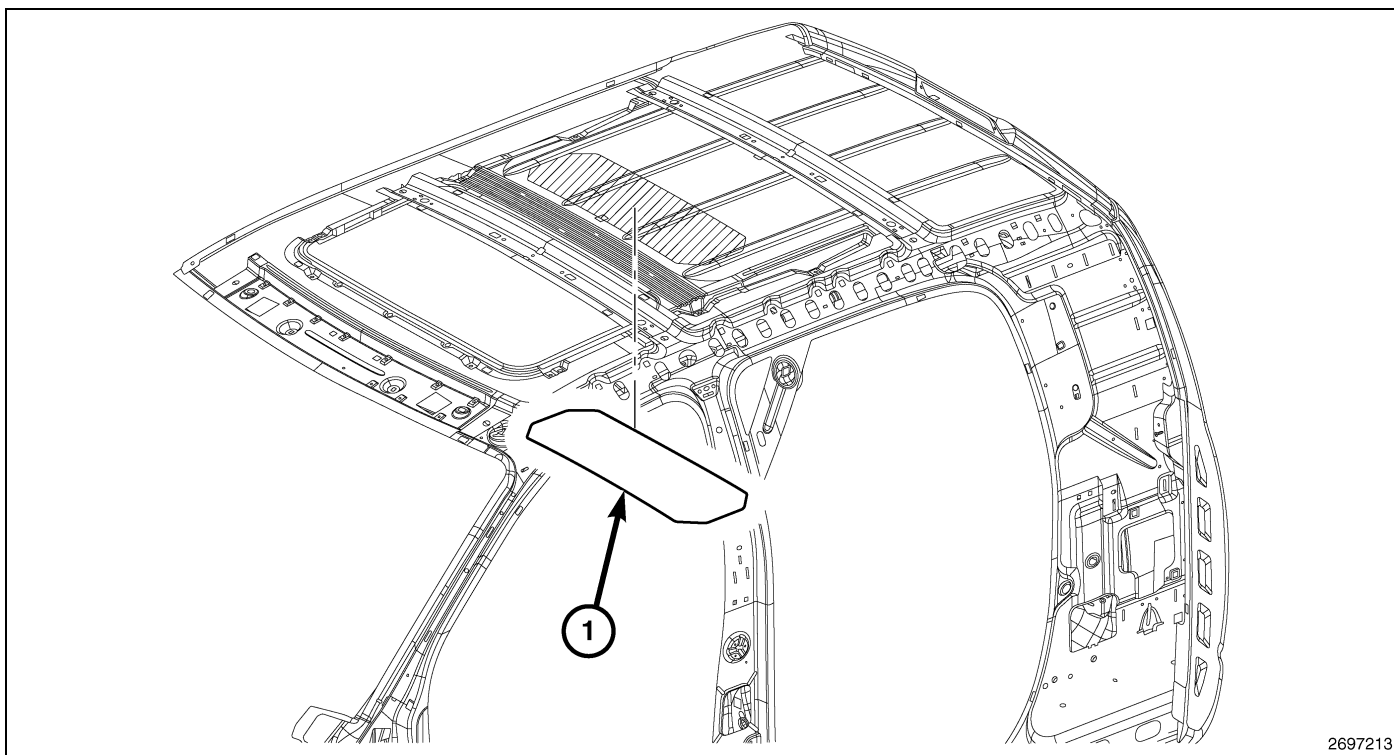

2697213

Fig. 45 ROOF – CREW CAB

1 - ROOF PANEL SOUND DEADENER PAD

SEALER LOCATIONS

All repairs where panels were replaced have voids that must be filled with sealant. Sealant should be applied to all skips, pin holes, in sealers and weld burn through holes on the interior and exterior of the vehicle that would permit leakage of water, air or exhaust fumes. Typical areas of the exterior that must be sealed are listed in this section. Areas of the interior that must be sealed are floor pans, wheelhouses, dash panel, and cowl sides.

NOTE: Preferred Mopar Product:

- **Paintable Seam Sealer—Part No. 04318026**

DESCRIPTION	FIGURE
Inner Body Side Panel and Cowl Side Panel	(Fig. 46)
Dash Panel/Cowl Side Panel (1 of 2)	(Fig. 47)
Dash Panel/Cowl Side Panel (2 of 2)	(Fig. 48)
Dash Panel/Front Floor Pan/Cowl Side Panel (1 of 2)	(Fig. 49)
Dash Panel/Front Floor Pan/Cowl Side Panel (2 of 2)	(Fig. 50)
Dash Panel/Front Floor Pan	(Fig. 51)
Front Floor Pan/Rear Floor Pan	(Fig. 52)
Rear Floor Pan/Cab Back Panel	(Fig. 53)
Inner Body Side Panel/Outer Body Side Panel (Above "C" Pillar)	(Fig. 54)
Cab Back Panel/Outer Body Side Panel	(Fig. 55)
Box Floor Panel/Box Front Panel	(Fig. 56)
Box Floor Panel/Box Floor Extension	(Fig. 57)
Hood	(Fig. 58)
Front Door – Standard Cab	(Fig. 59)

DESCRIPTION	FIGURE
Front Door – Quad, Crew Cab	(Fig. 60)
Rear Door	(Fig. 61)
Tailgate	(Fig. 62)

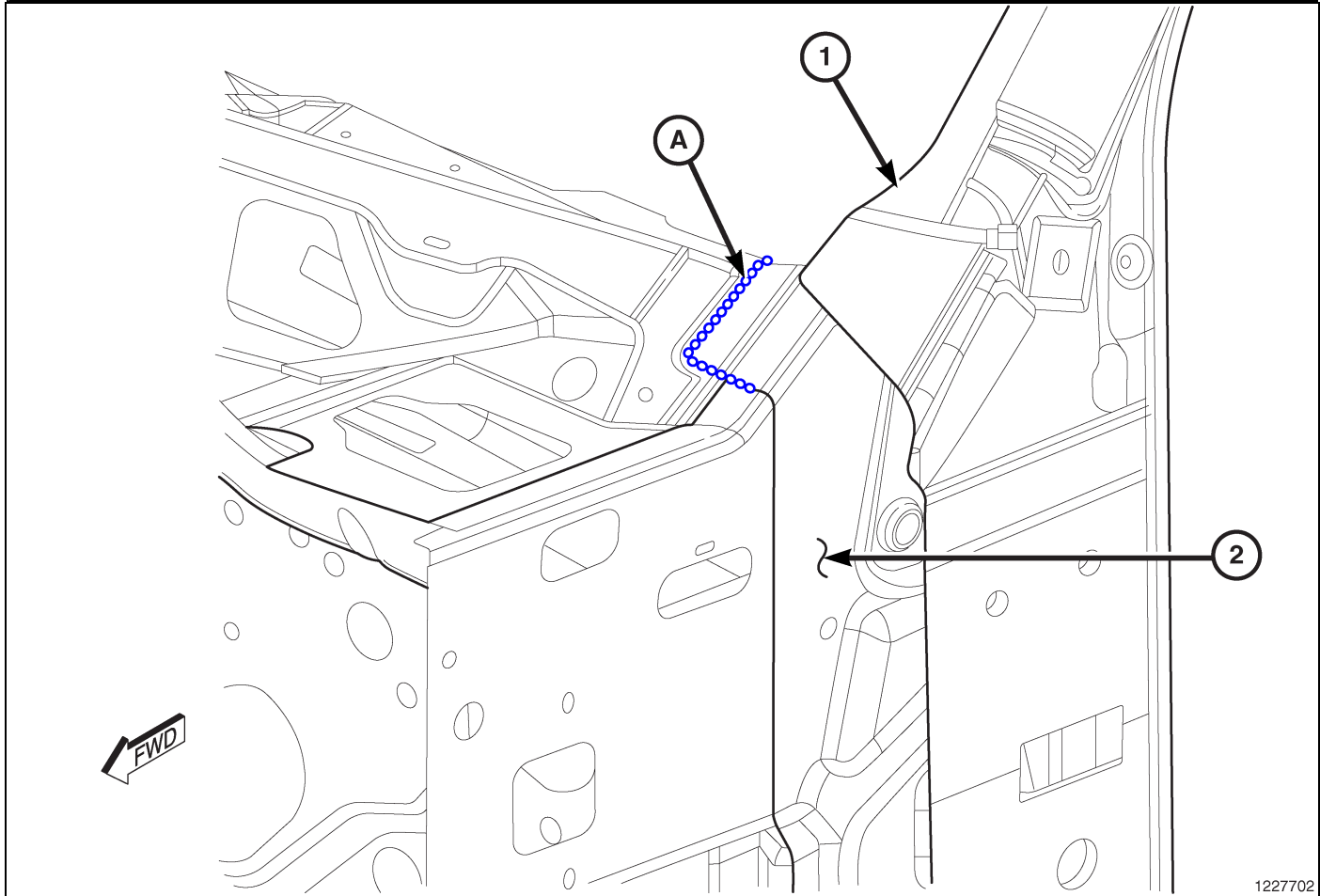

Fig. 46 Inner Body Side Panel and Cowl Side Panel

NOTE: Left side shown, right side typical

A - SEAM SEALER

1 - INNER BODY SIDE PANEL

2 - COWL SIDE PANEL

1227702

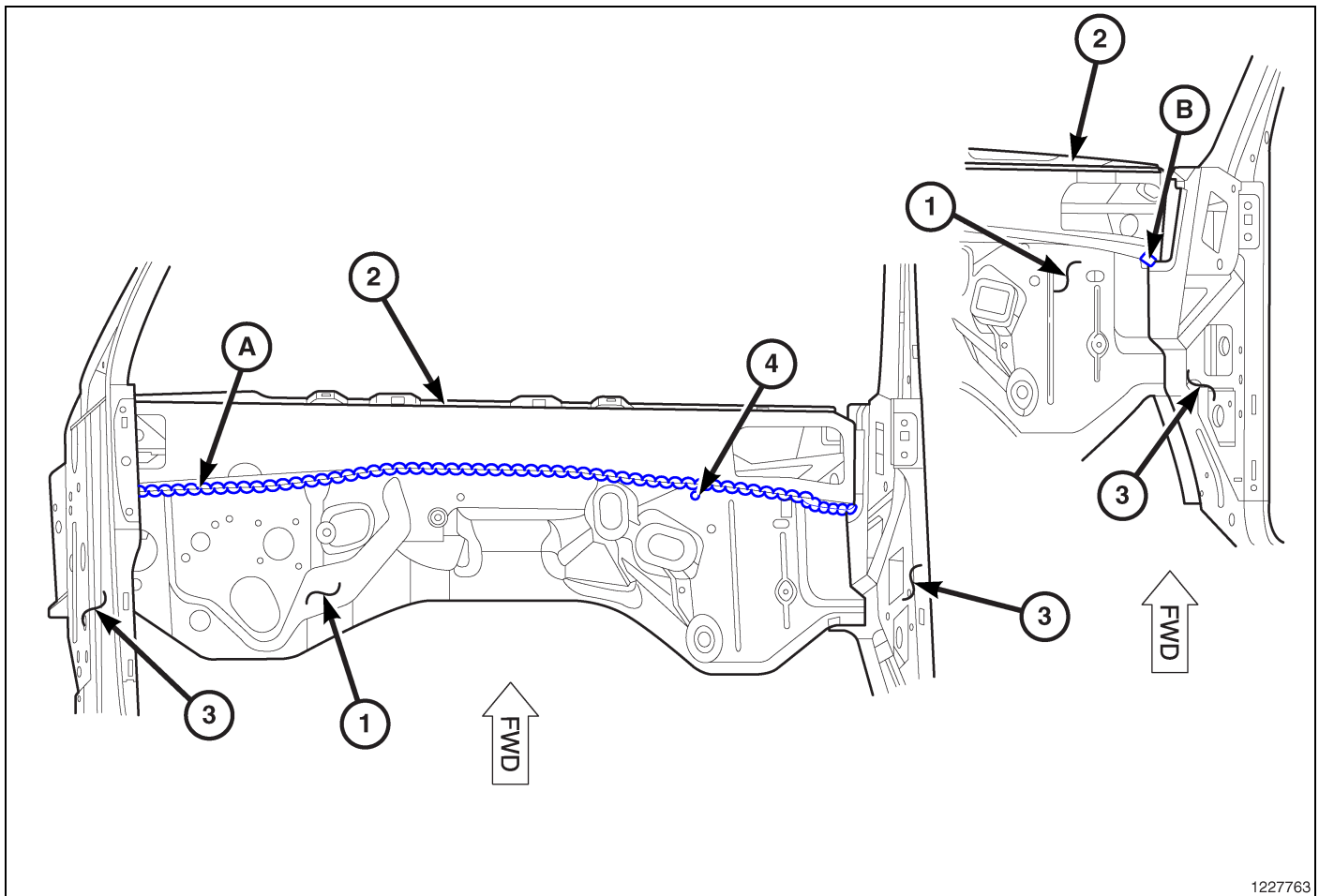

Fig. 47 Dash Panel/Cowl Side Panel (1 of 2)

NOTE: Right side shown left side typical. Keep sealer off of instrument panel locating studs.

A - SEAM SEALER

B - THUMBGRADE SEALER

1 - UPPER DASH PANEL

2 - LOWER PLENUM

3 - COWL SIDE PANEL

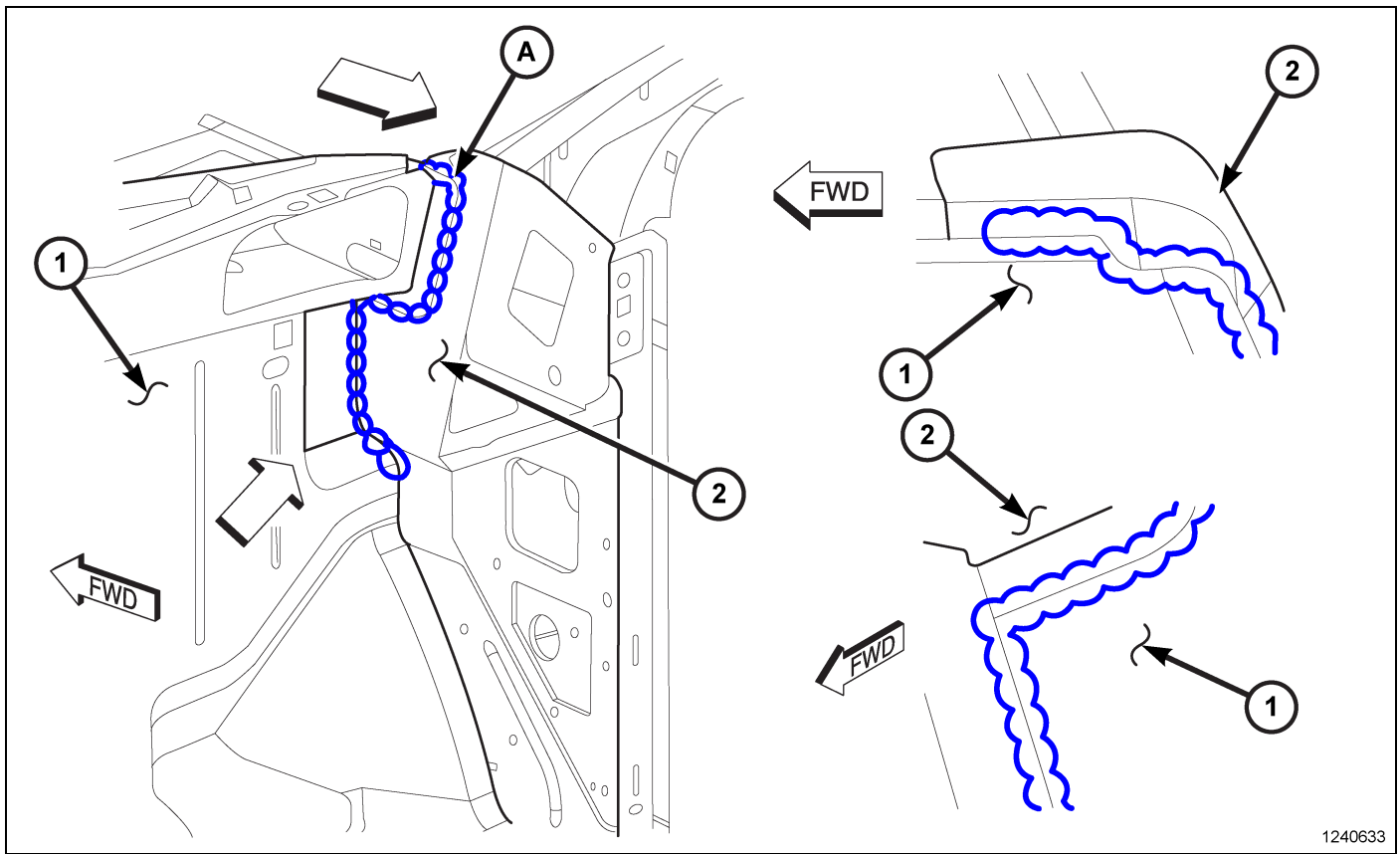

Fig. 48 Dash Panel/Cowl Side Panel (2 of 2)

NOTE: Right side shown, left side typical.

A - SEAM SEALER

1 - DASH PANEL

2 - COWL SIDE PANEL

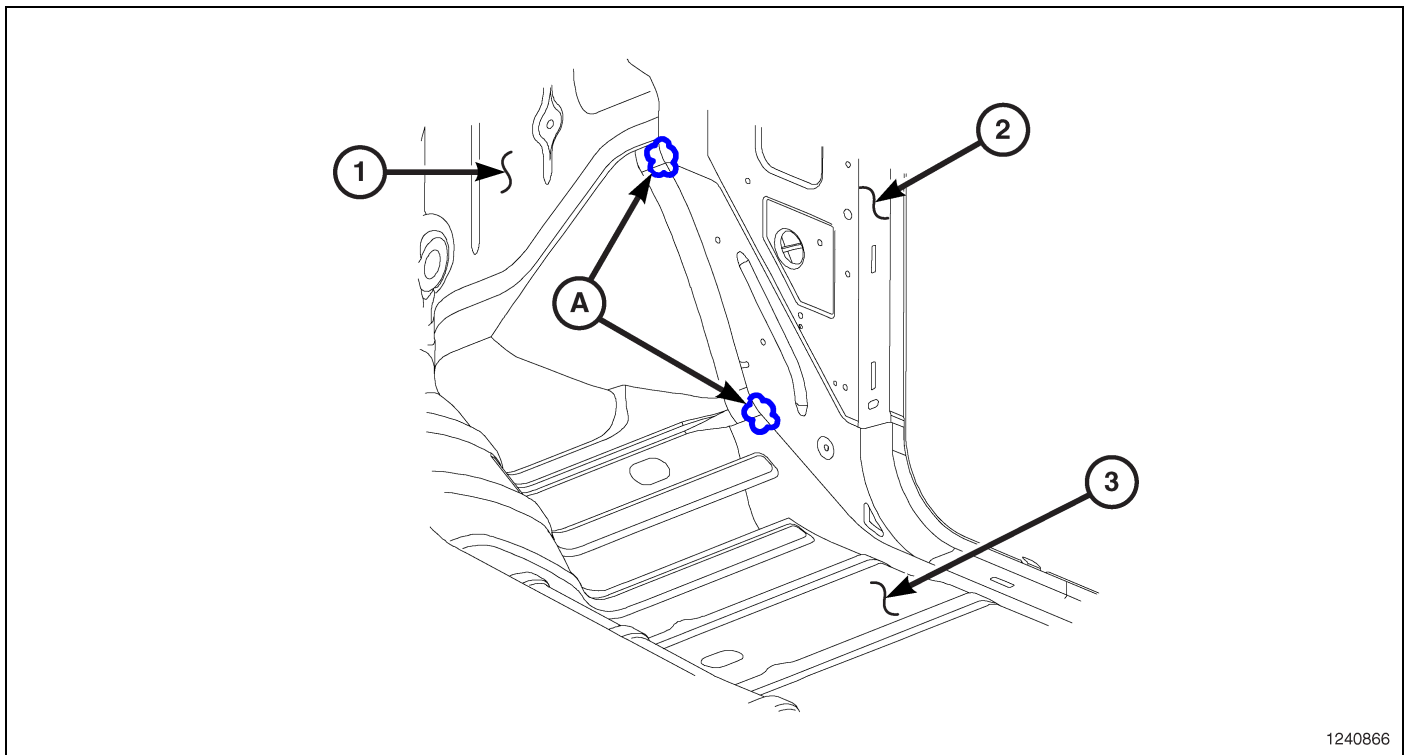

1240866

Fig. 49 Dash Panel/Front Floor Pan/Cowl Side Panel (1 of 2)

NOTE: Right side shown, left side typical.

A - SEAM SEALER

1 - DASH PANEL

2 - COWL SIDE PANEL

3 - FRONT FLOOR PAN

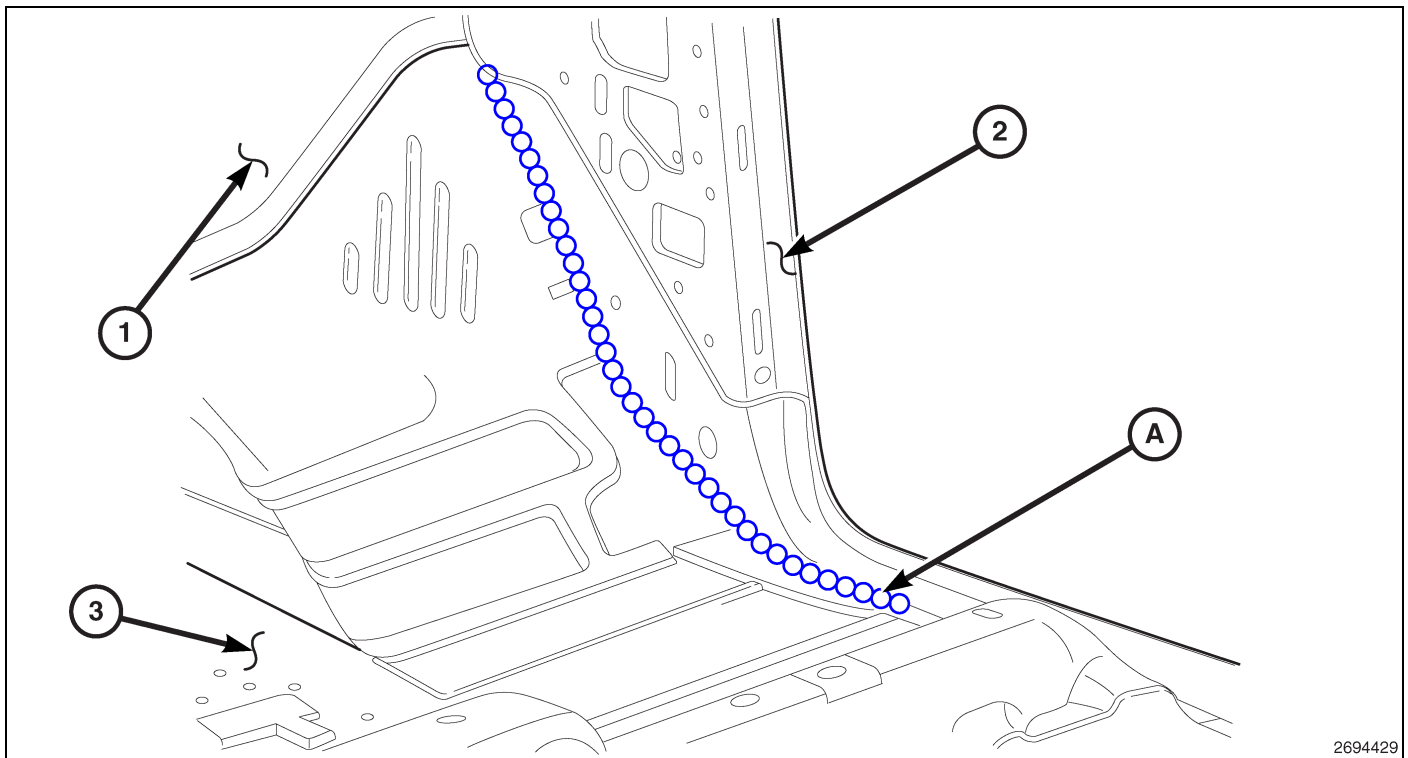

Fig. 50 Dash Panel/Front Floor Pan/Cowl Side Panel (2 of 2)

A - SEAM SEALER

1 - DASH PANEL

2 - COWL SIDE PANEL

3 - FRONT FLOOR PAN

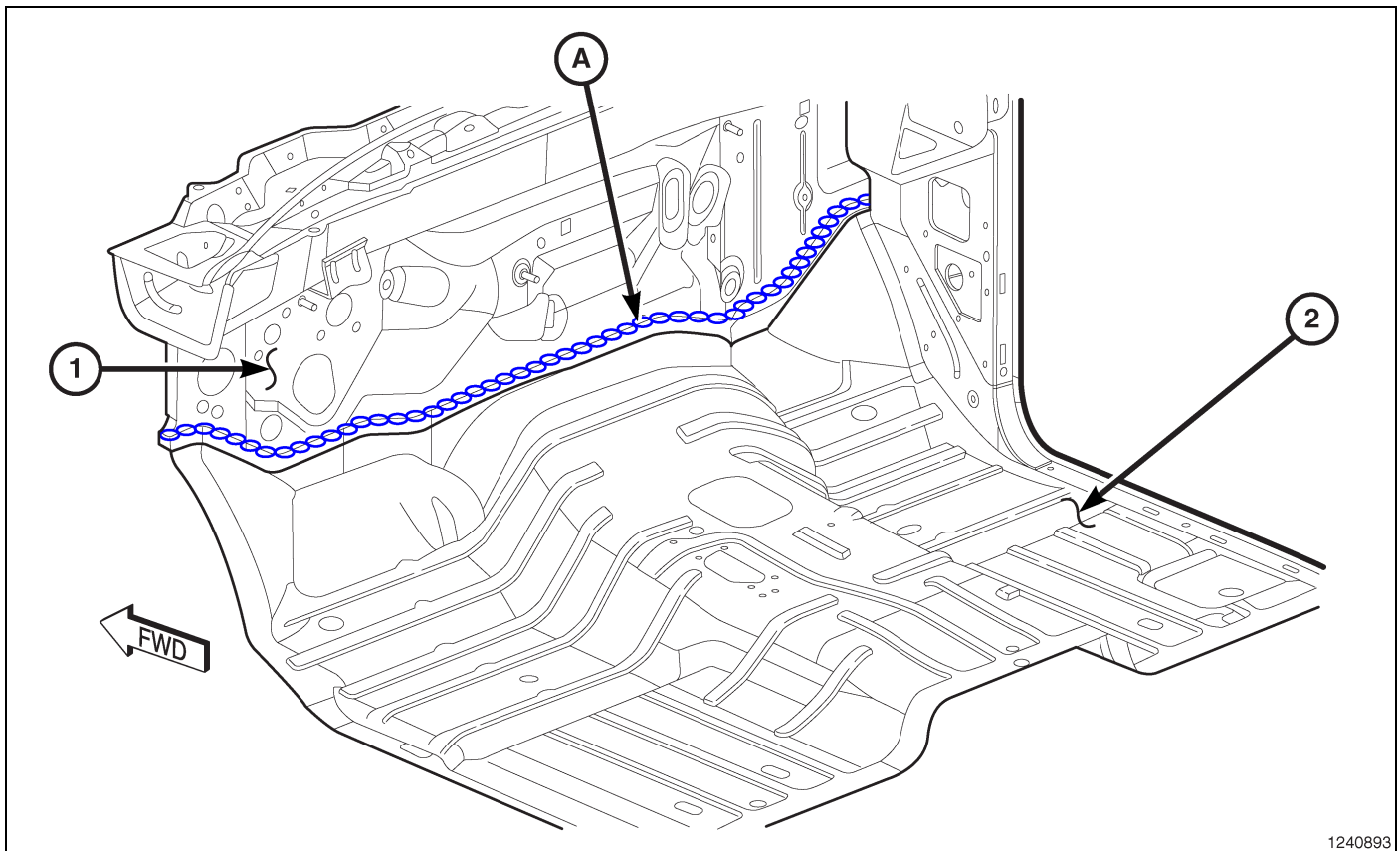

Fig. 51 Dash Panel/Front Floor Pan

A - SEAM SEALER

1 - DASH PANEL

2 - FRONT FLOOR PAN

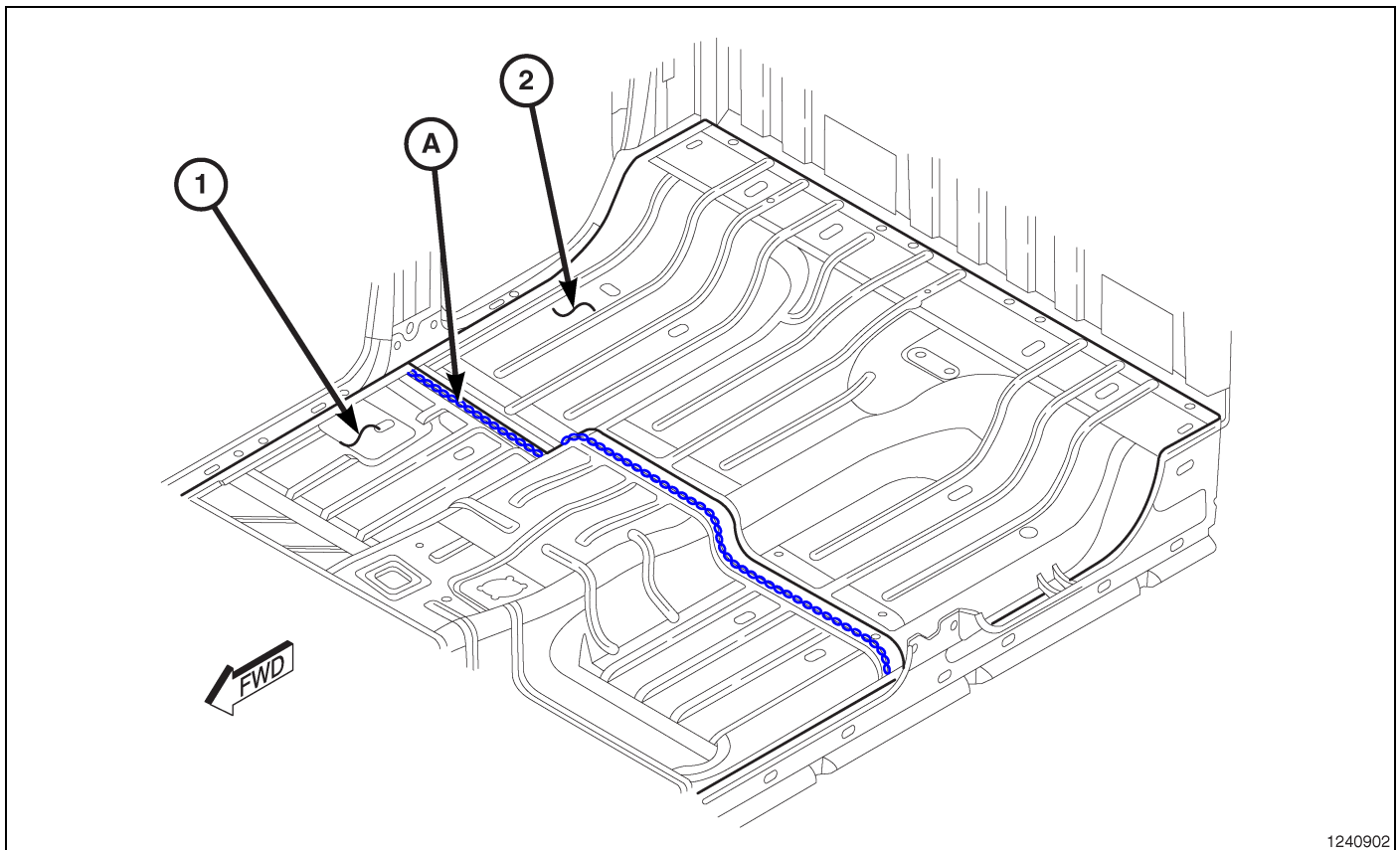

Fig. 52 Front Floor Pan/Rear Floor Pan

NOTE: Quad cab shown, standard and crew cabs similar.

A - SEAM SEALER

1 - FRONT FLOOR PAN

2 - REAR FLOOR PAN

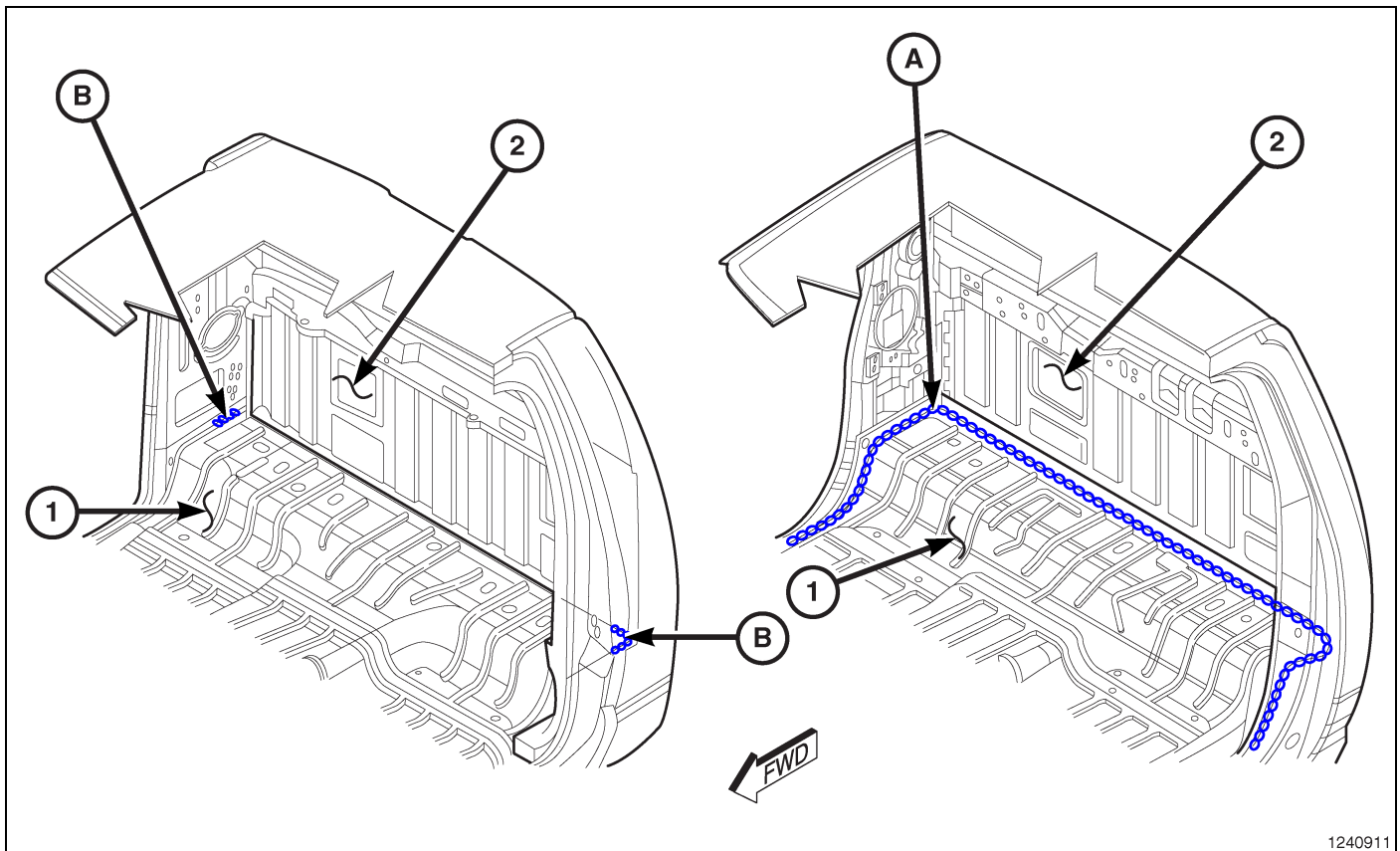

Fig. 53 Rear Floor Pan/Cab Back Panel

NOTE: Standard cab shown, quad and crew cab similar.

A - SEAM SEALER

B - THUMBGRADE SEALER

1 - REAR FLOOR PAN

2 - CAB BACK PANEL

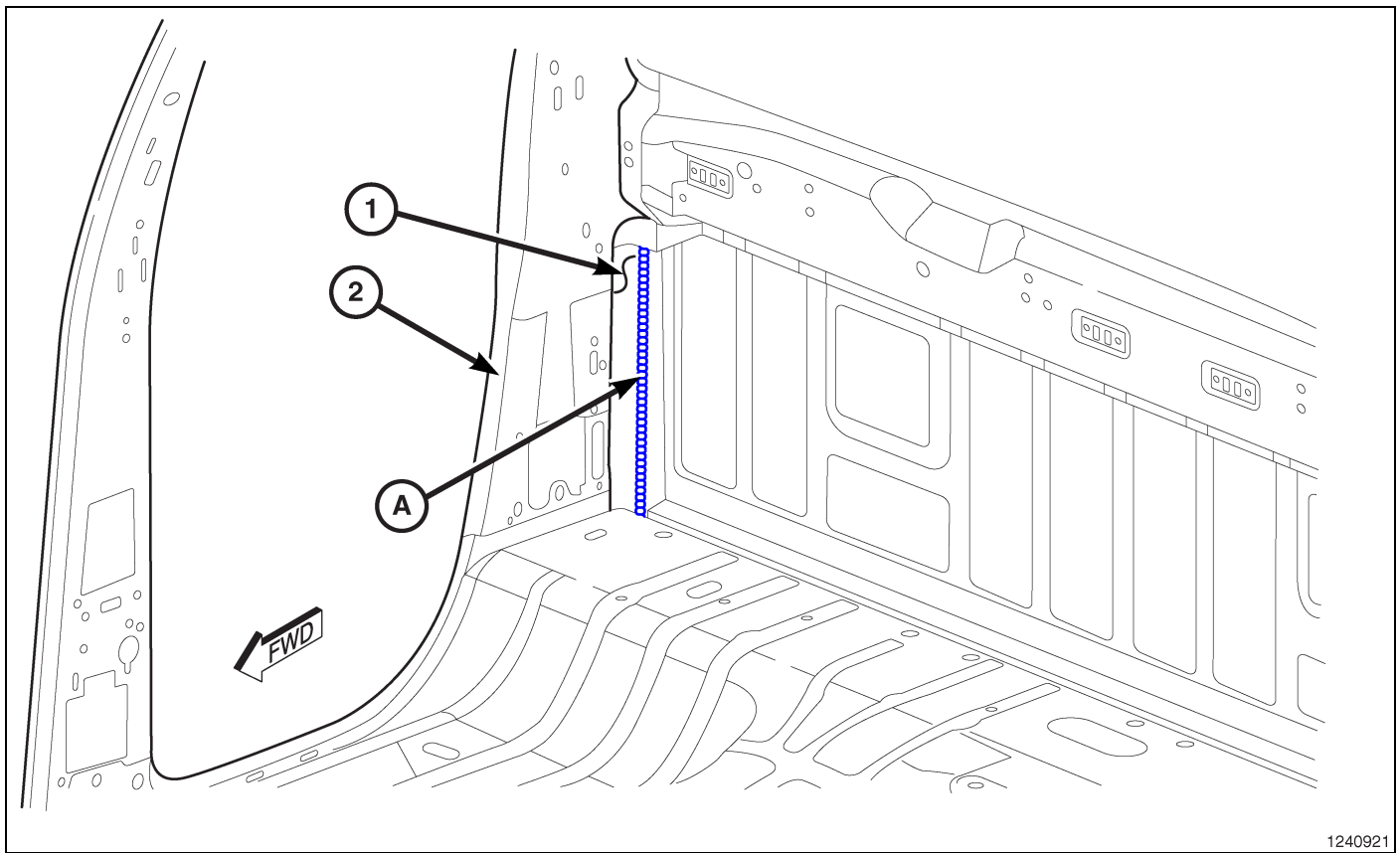

Fig. 54 Inner Body Side Panel/Outer Body Side Panel (Above "C" Pillar)

NOTE: Quad cab shown, standard and crew cabs similar.

A - SEAM SEALER

1 - INNER BODY SIDE PANEL

2 - OUTER BODY SIDE PANEL

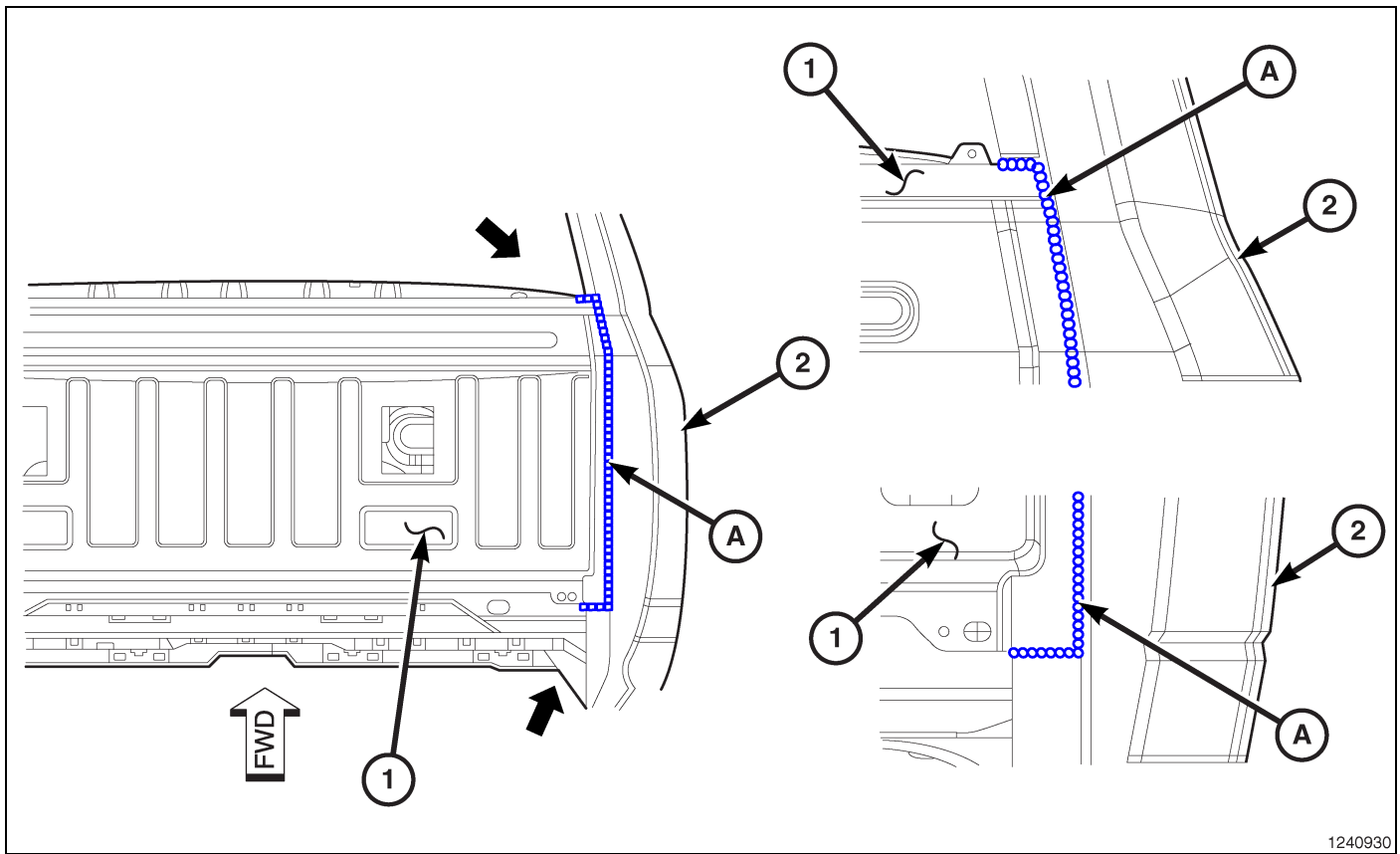

Fig. 55 Cab Back Panel/Outer Body Side Panel

NOTE: Right side shown, left side typical.

A - SEAM SEALER

1 - CAB BACK PANEL

2 - OUTER BODY SIDE PANEL

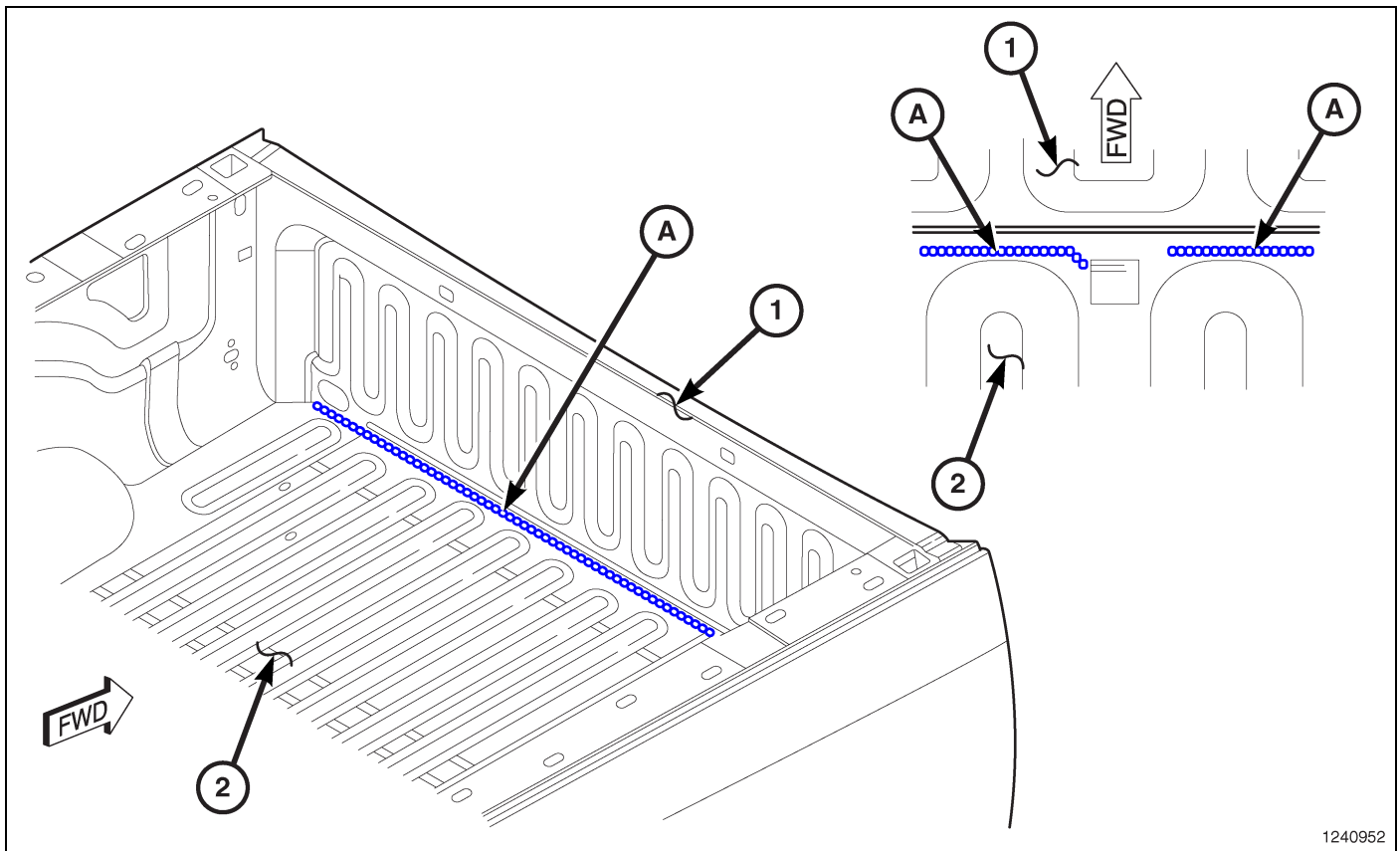

1240952

Fig. 56 Box Floor Panel/Box Front Panel

- A - SEAM SEALER
- 1 - BOX FRONT PANEL
- 2 - BOX FLOOR PANEL

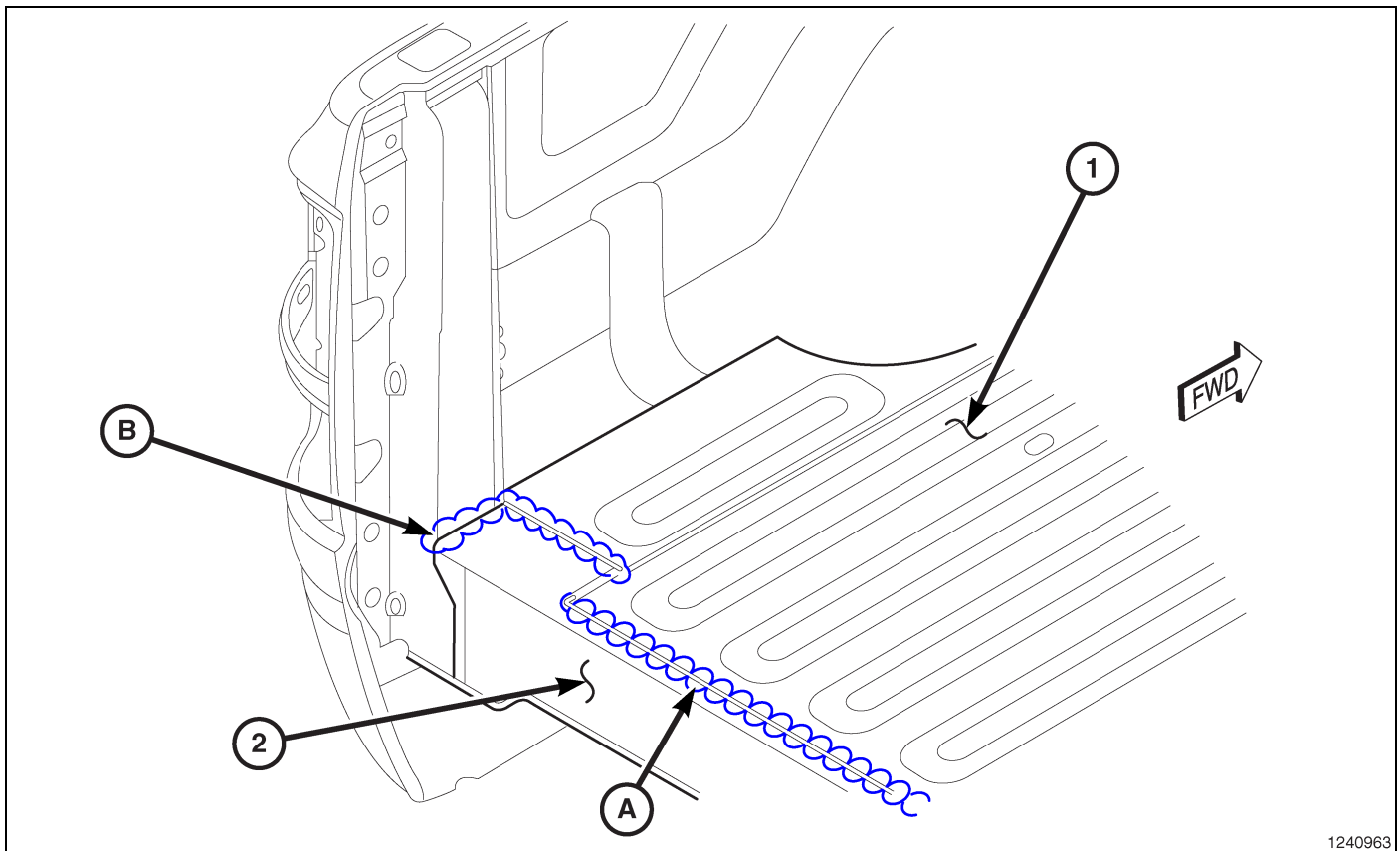

1240963

Fig. 57 Box Floor Panel/Box Floor Extension

NOTE: Left side shown, right side typical.

A - SEAM SEALER

B - SEAM SEALER

1 - BOX FLOOR PANEL

2 - BOX FLOOR EXTENSION

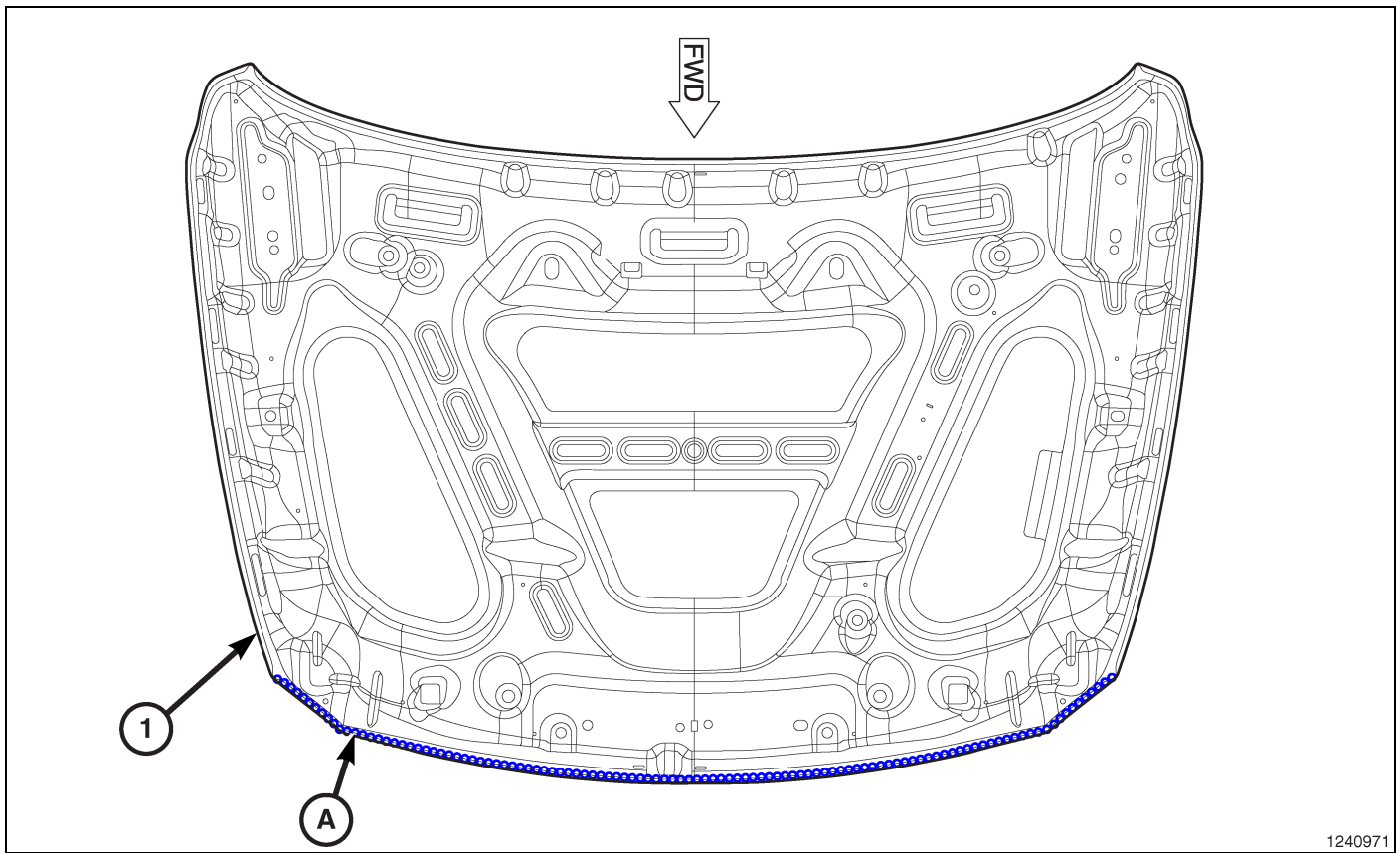

1240971

Fig. 58 Hood

A - SEAM SEALER

1 - HOOD PANEL (INNER/OUTER)

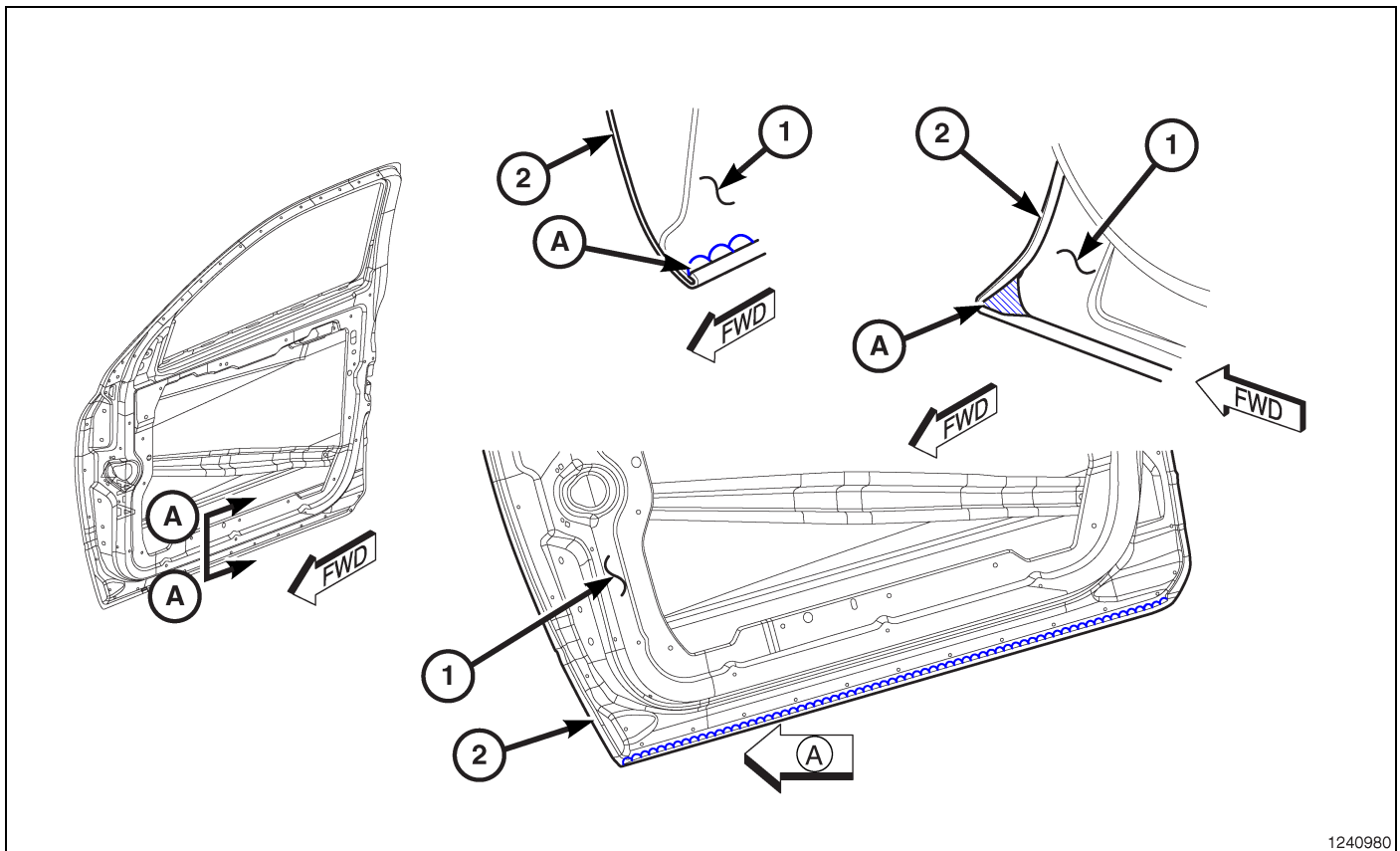

Fig. 59 Front Door – Standard Cab

A - SEAM SEALER

1 - INNER DOOR PANEL

2 - OUTER DOOR PANEL

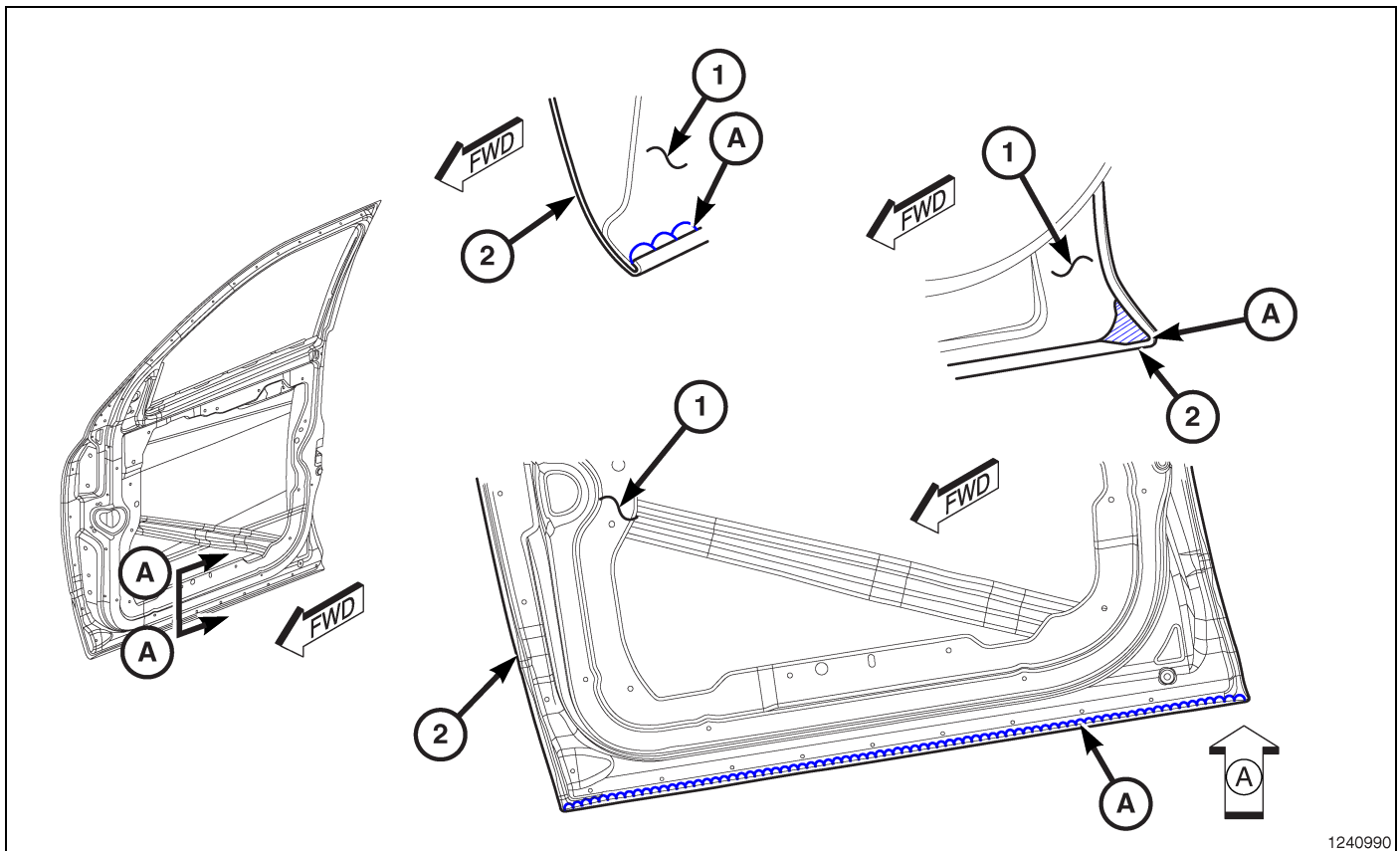
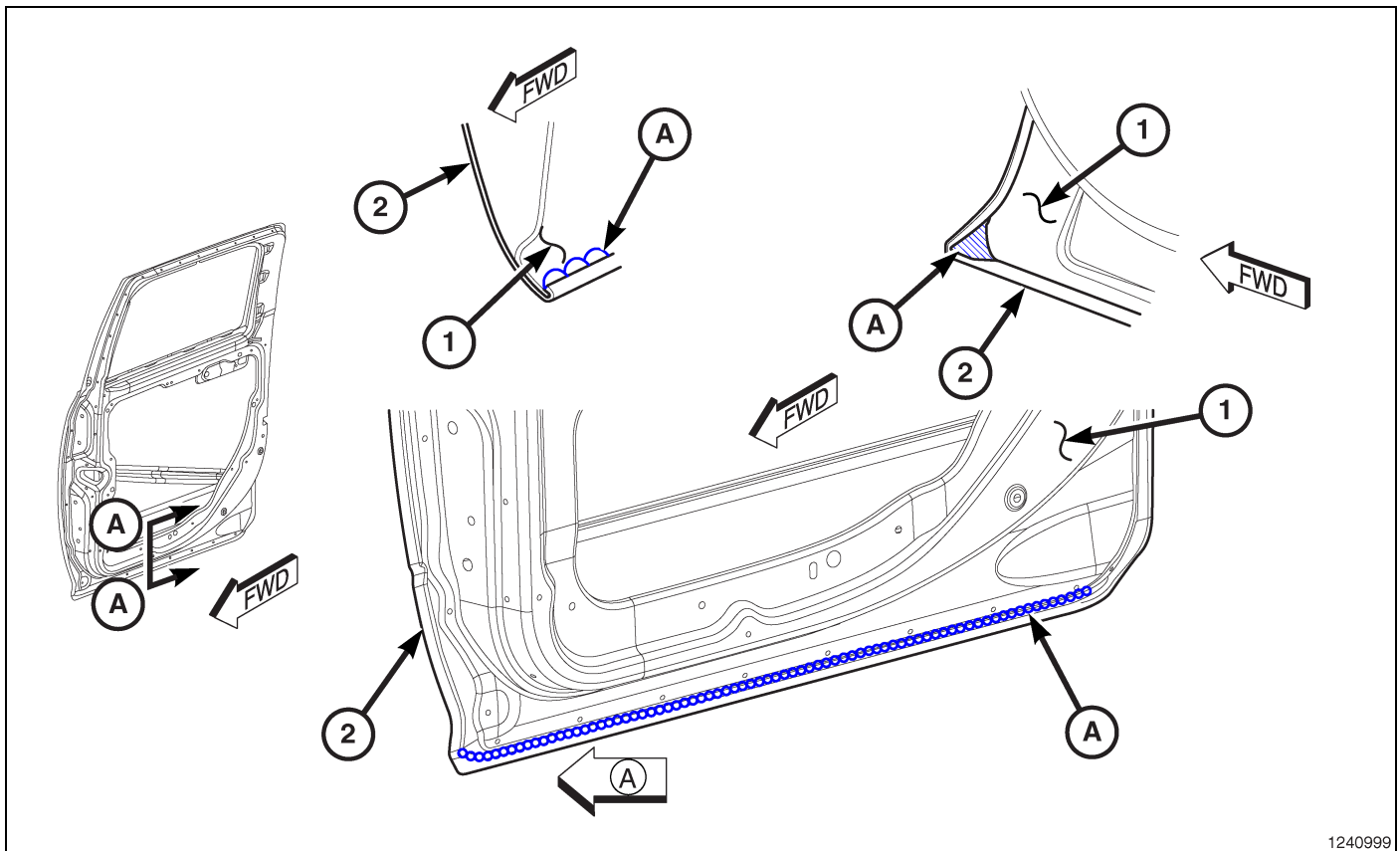

Fig. 60 Front Door – Quad, Crew Cab

- A - SEAM SEALER
- 1 - INNER DOOR PANEL
- 2 - OUTER DOOR PANEL



1240999

Fig. 61 Rear Door

A - SEAM SEALER

1 - INNER DOOR PANEL

2 - OUTER DOOR PANEL

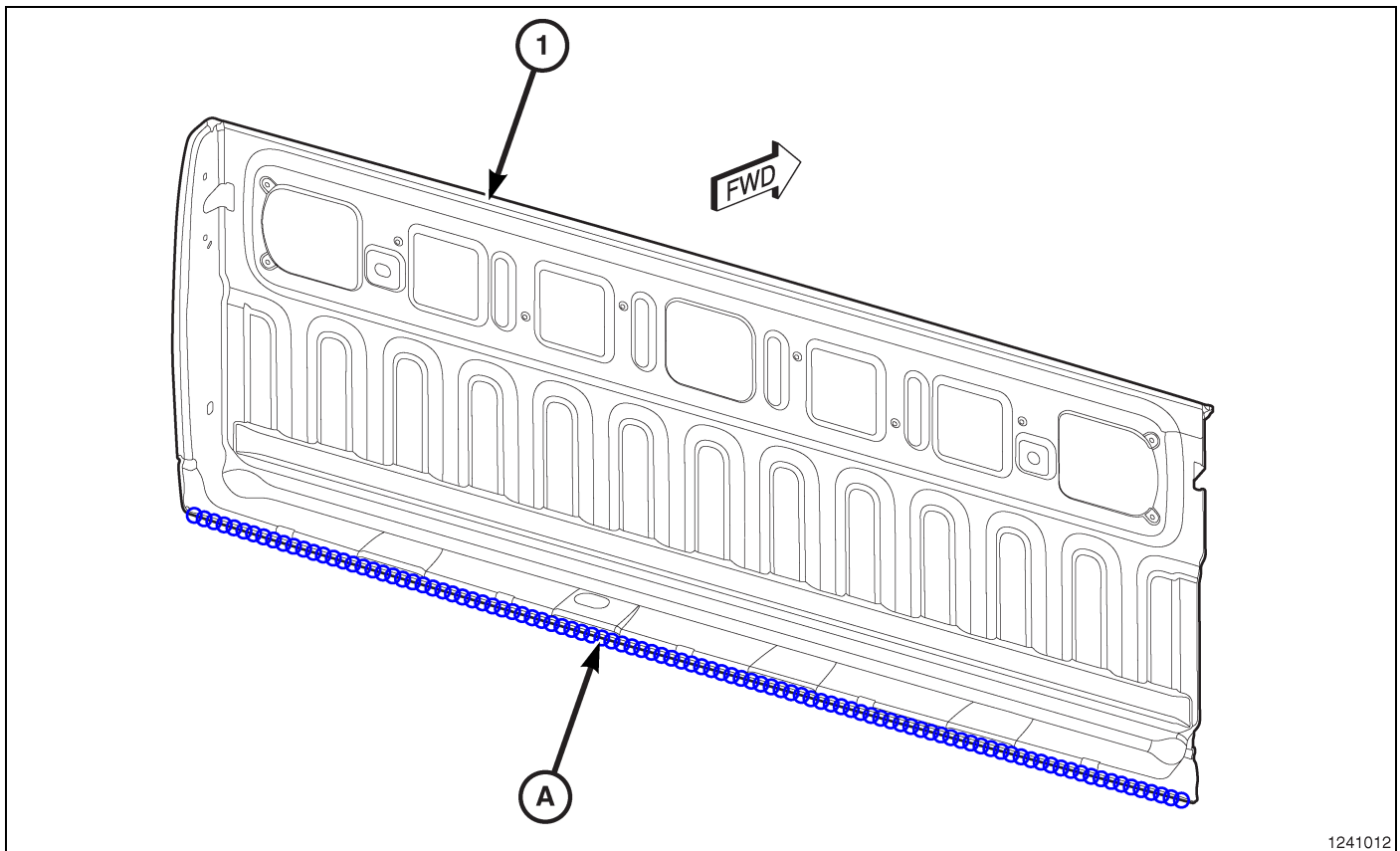

1241012

Fig. 62 Tailgate

STRUCTURAL ADHESIVE LOCATIONS

DESCRIPTION	FIGURE
Miscellaneous Components	(Fig. 63)
Front Floor – Quad Cab	(Fig. 64)
Front Floor – Crew Cab	(Fig. 65)
Underbody Complete – Quad Cab	(Fig. 66)
Underbody Complete – Crew Cab	(Fig. 67)
Body Side Aperture Complete – Standard Cab	(Fig. 68)
Body Side Aperture Outer – Crew Cab (1 of 2)	(Fig. 69)
Body Side Aperture Outer – Crew Cab (2 of 2)	(Fig. 70)
Cab Complete – Standard (1 of 2)	(Fig. 71)
Cab Complete – Standard (2 of 2)	(Fig. 72)
Cab Complete – Quad (1 of 4)	(Fig. 73)
Cab Complete – Quad (2 of 4)	(Fig. 74)
Cab Complete – Quad (3 of 4)	(Fig. 75)
Cab Complete – Quad (4 of 4)	(Fig. 76)
Cab Complete – Crew (1 of 5)	(Fig. 77)
Cab Complete – Crew (2 of 5)	(Fig. 78)
Cab Complete – Crew (3 of 5)	(Fig. 79)
Cab Complete – Crew (4 of 5)	(Fig. 80)
Cab Complete – Crew (5 of 5)	(Fig. 81)

DESCRIPTION	FIGURE
5.7' Ram Box Floor	(Fig. 82)
6.3' Box Tub	(Fig. 83)
6.3' Box Floor	(Fig. 84)
8.0' Box Body in White	(Fig. 85)
8.0' Box Tub	(Fig. 86)
8.0' Box Floor	(Fig. 87)
Front Doors - Short	(Fig. 88)
Front Doors - Long	(Fig. 89)
Rear Doors - Half	(Fig. 90)
Rear Doors - Full	(Fig. 91)
Tailgate	(Fig. 92)

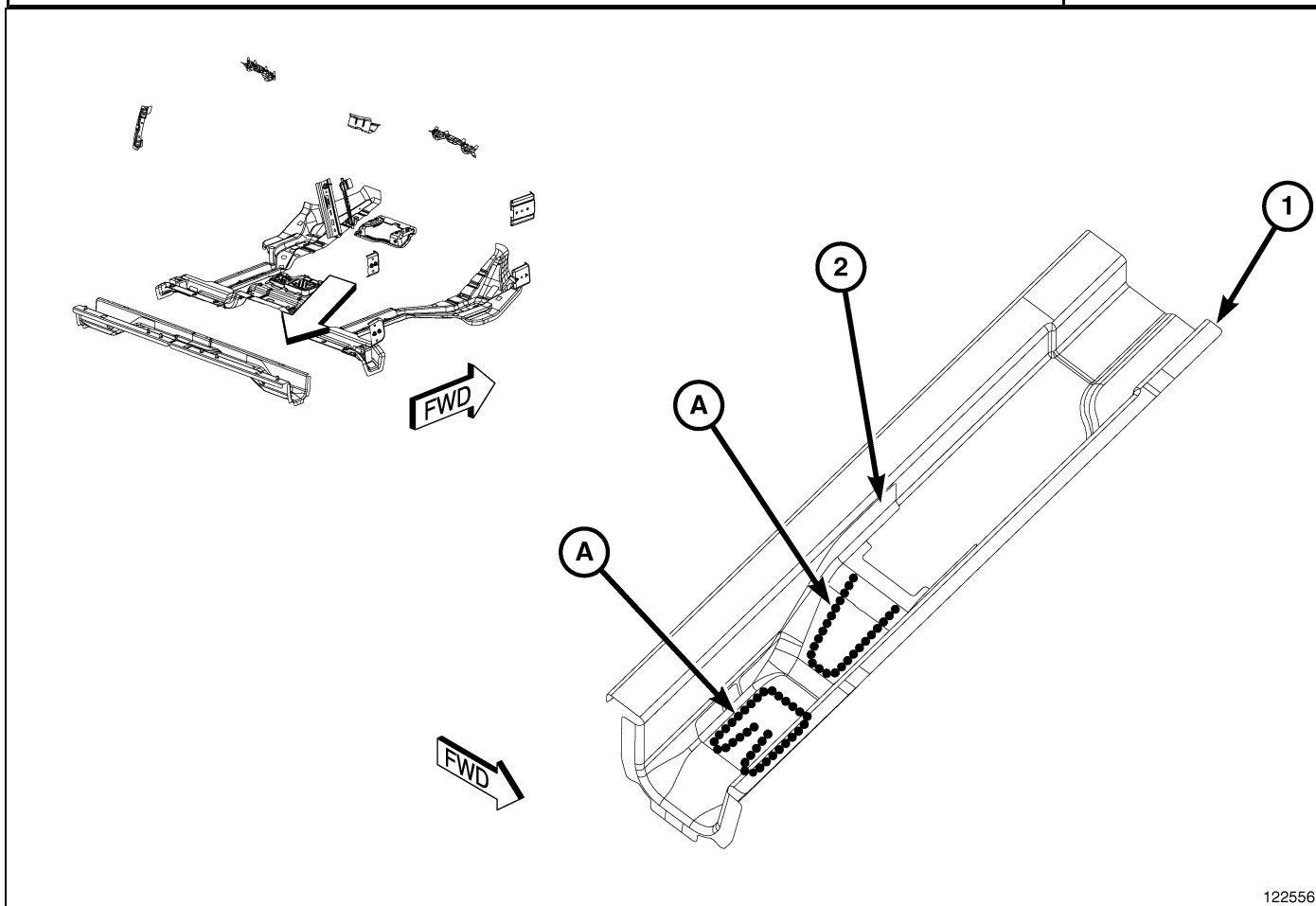

1225561

Fig. 63 MISCELLANEOUS COMPONENTS - STANDARD AND QUAD CAB ONLY

A - ORDINARY STRUCTURAL ADHESIVE

1 - REAR FLOOR CROSSMEMBER

2 - UNDERBODY HOLD-DOWN REINFORCEMENT

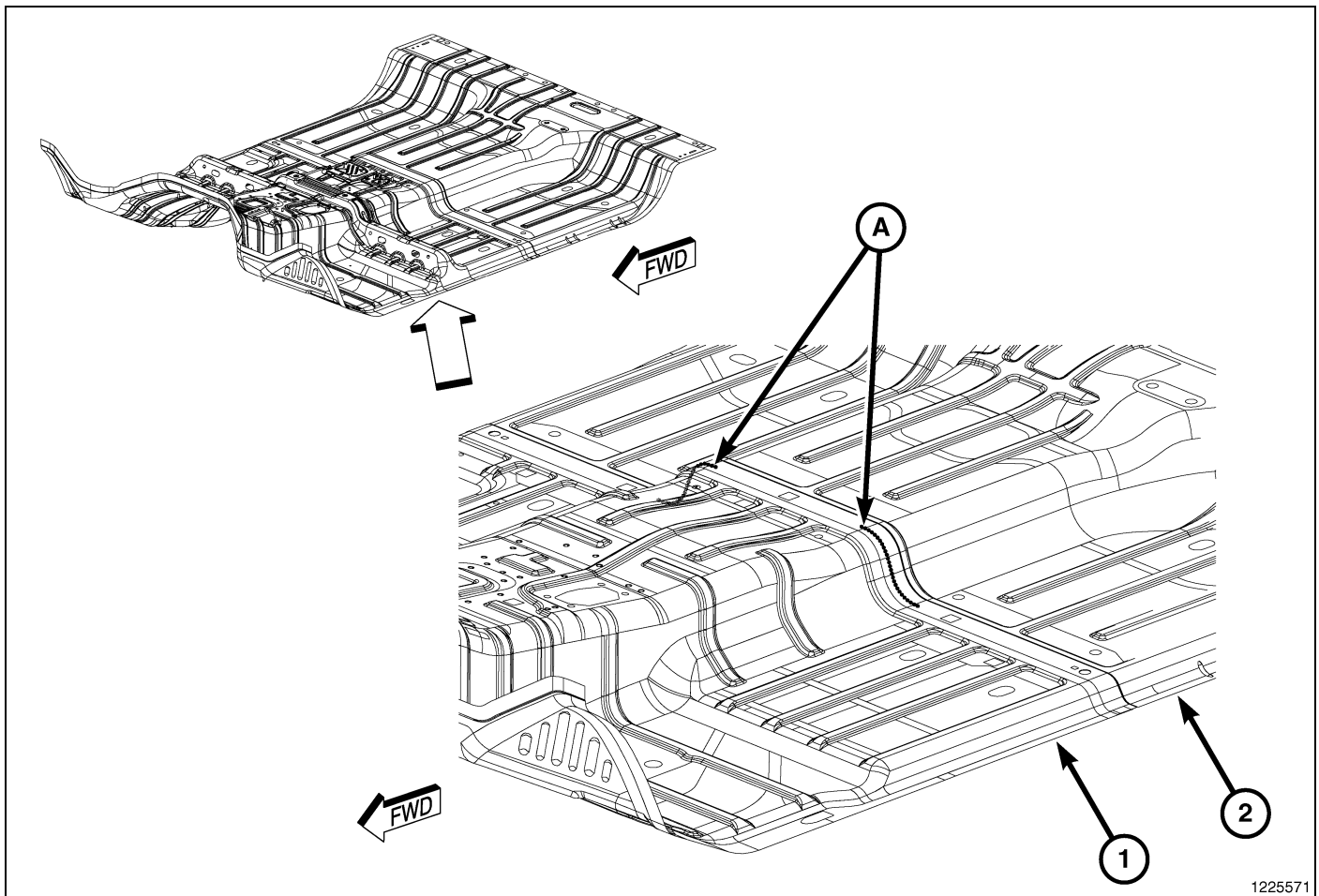

Fig. 64 Front Floor – Quad Cab

A - ORDINARY STRUCTURAL ADHESIVE

1 - FRONT FLOOR PAN

2 - REARFLOOR PAN

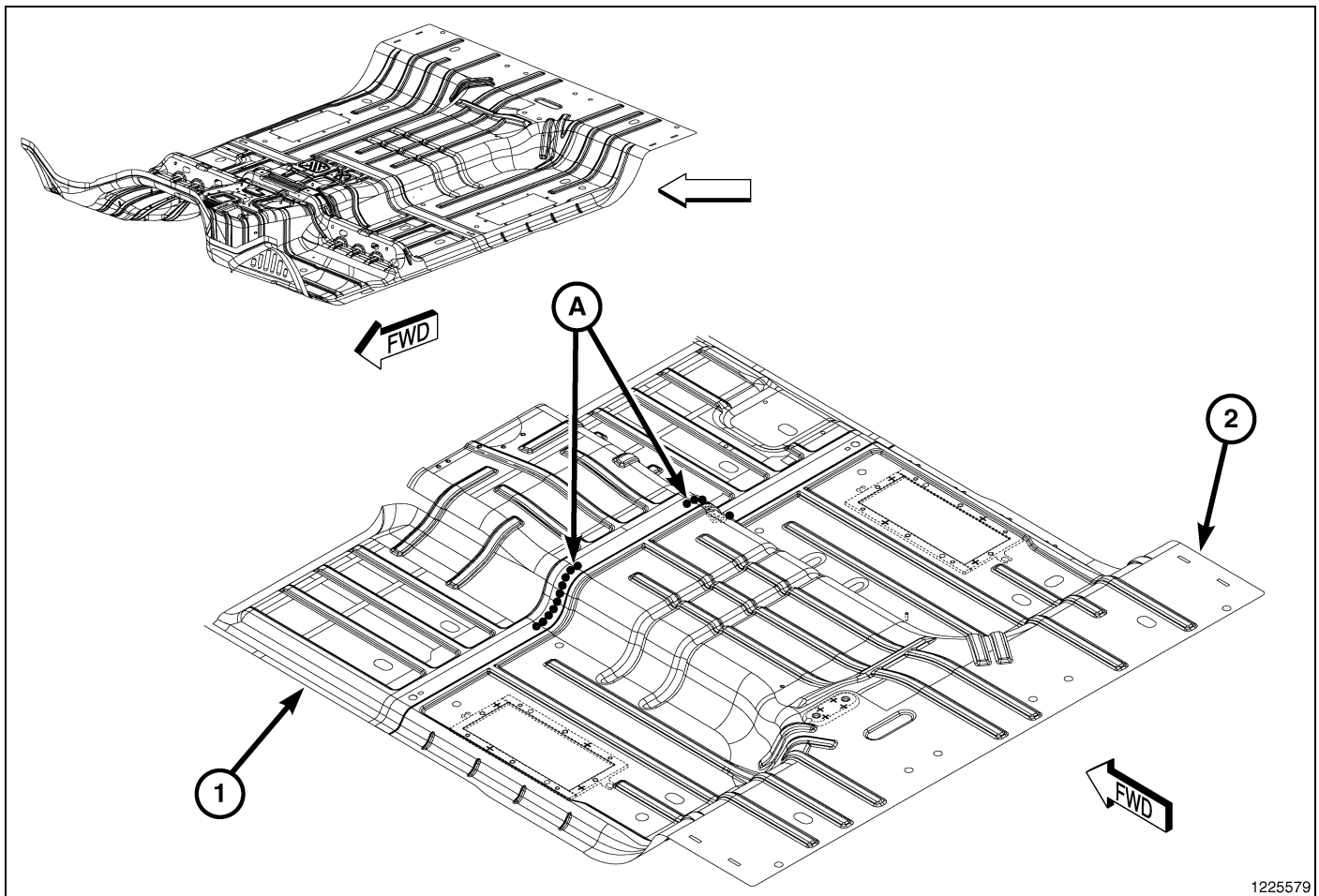

Fig. 65 Front Floor – Crew Cab

A - ORDINARY STRUCTURAL ADHESIVE

1 - FRONT FLOOR PAN

2 - REAR FLOOR PAN

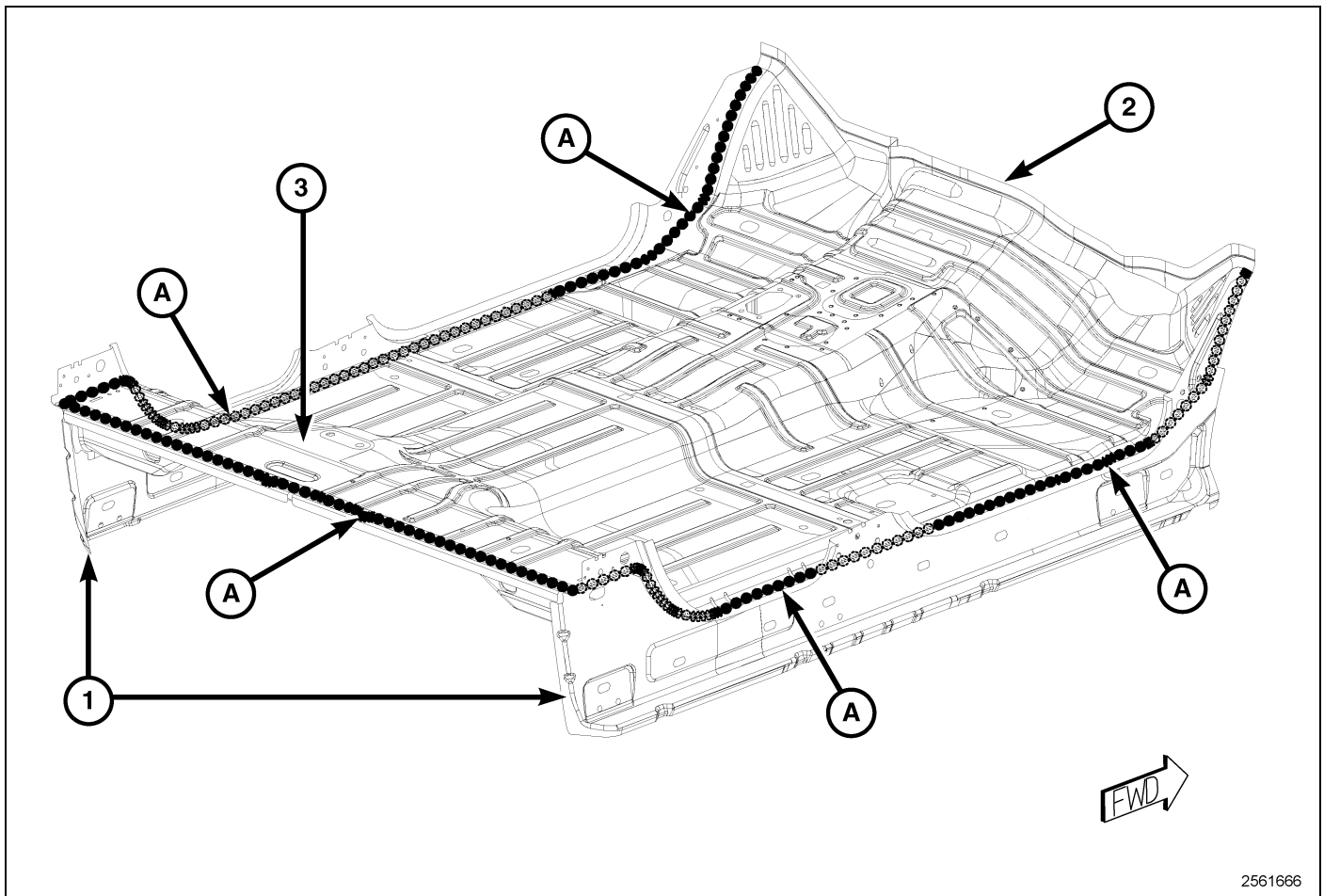

Fig. 66 Underbody Complete – Quad Cab

A - ORDINARY STRUCTURAL ADHESIVE

1 - CAB FLOOR SILL

2 - FRONT FLOOR PAN

3 - REAR FLOOR PAN

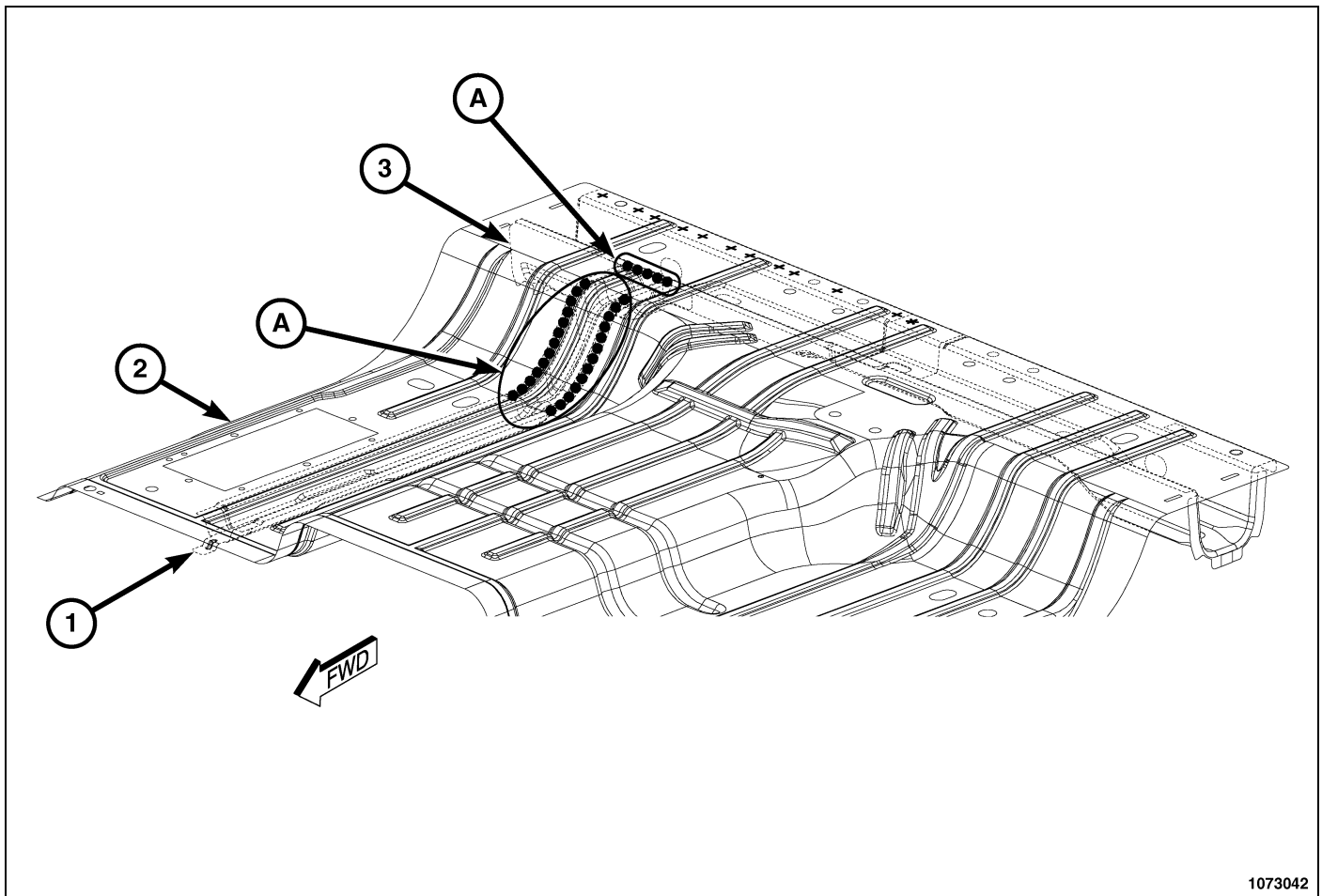

1073042

Fig. 67 Underbody Complete – Crew Cab

A - ORDINARY STRUCTURAL ADHESIVE

1 - FLOOR SUPPORT

2 - REAR FLOOR PAN

3 - REAR FLOOR CROSSMEMBER

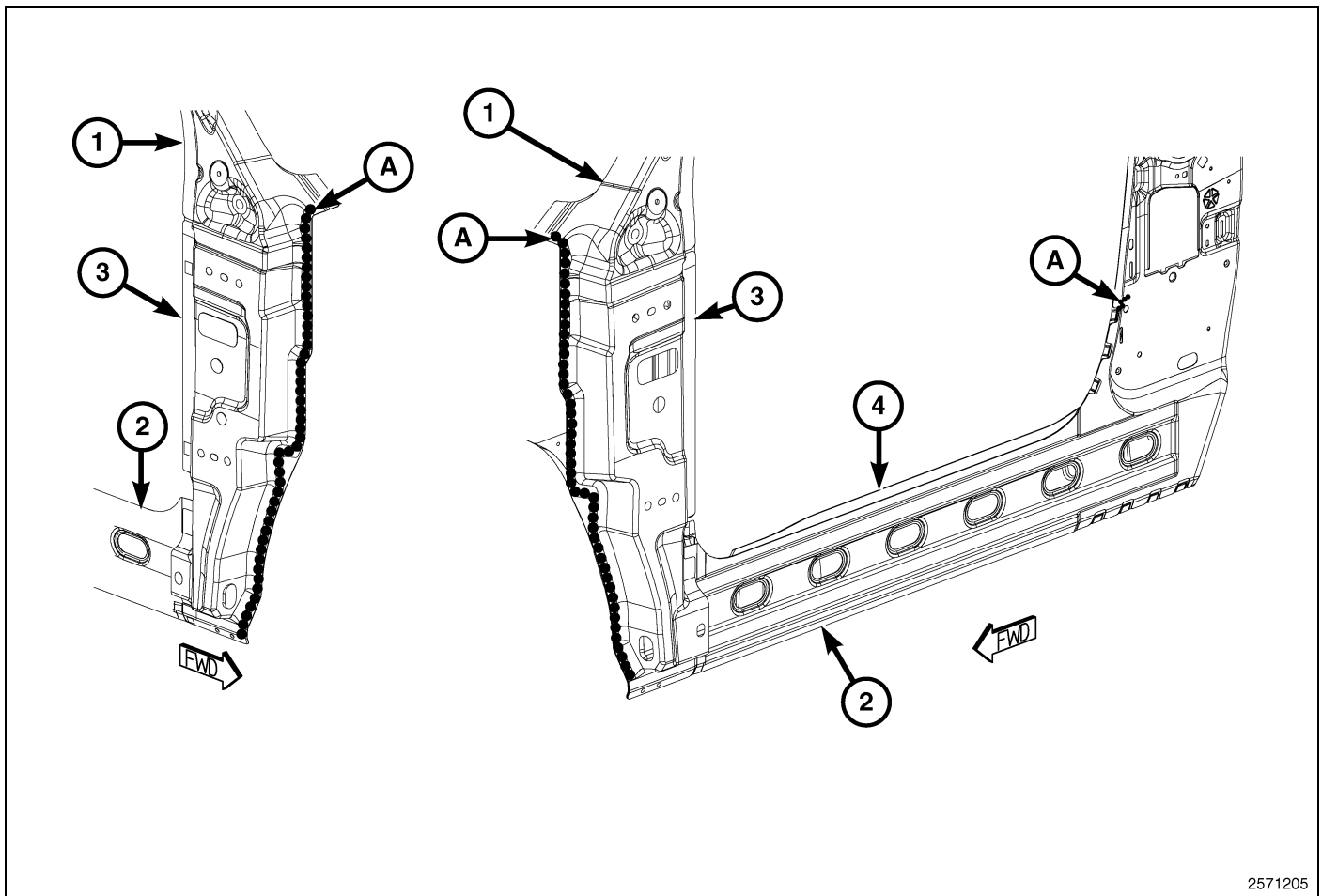

2571205

Fig. 68 Body Side Aperture Complete – Standard Cab

A - ORDINARY STRUCTURAL ADHESIVE

1 - A-PILLAR REINFORCEMENT

2 - INNER BODY SIDE PANEL

3 - DOOR HING REINFORCMENT

4 - CAB SILL

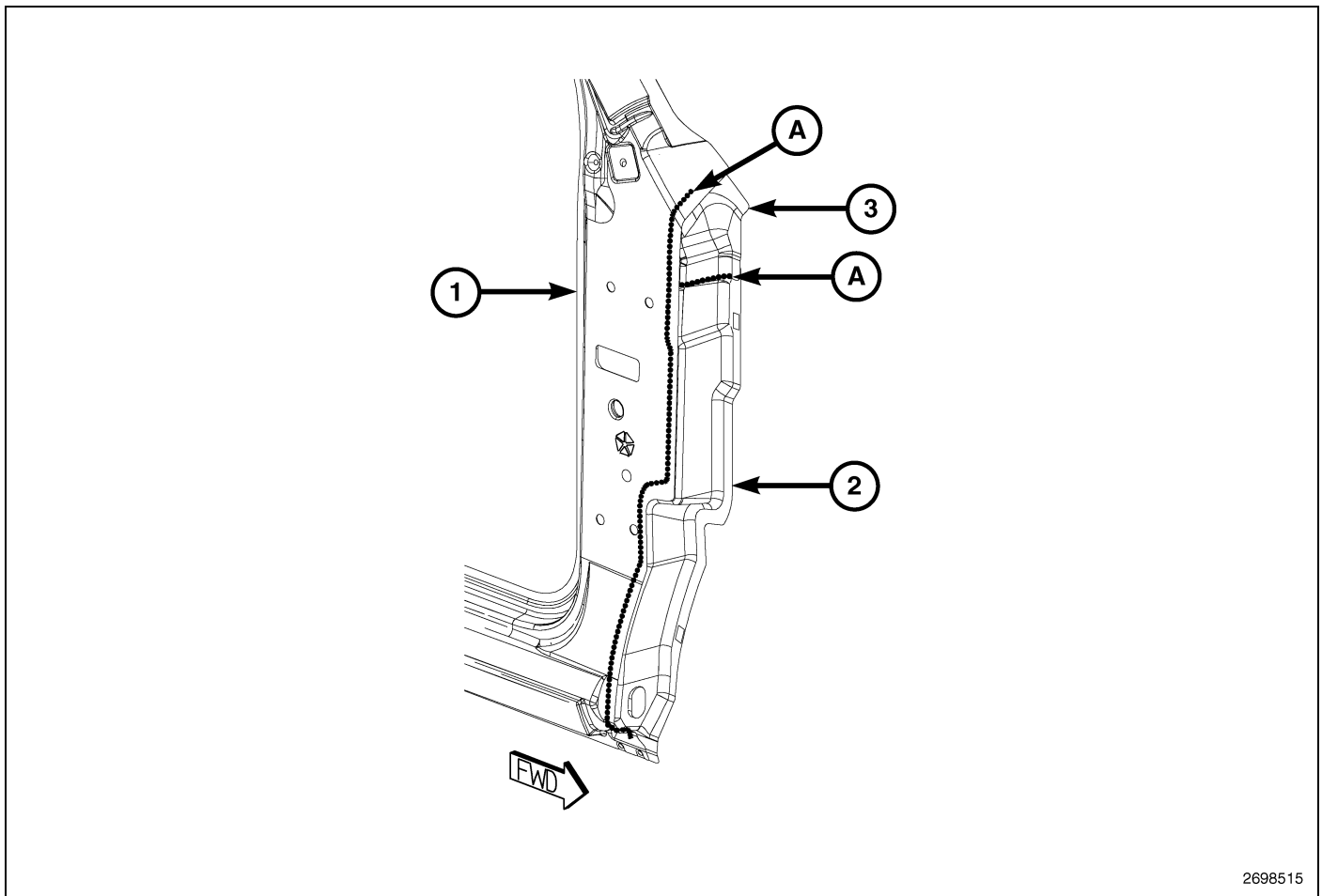

2698515

Fig. 69 Body Side Aperture Outer – Crew Cab (1 of 2)

A - ORDINARY STRUCTURAL ADHESIVE

1 - OUTER BODY SIDE PANEL

2 - DOOR HINGE REINFORCEMENT

3 - A-PILLAR REINFORCEMENT

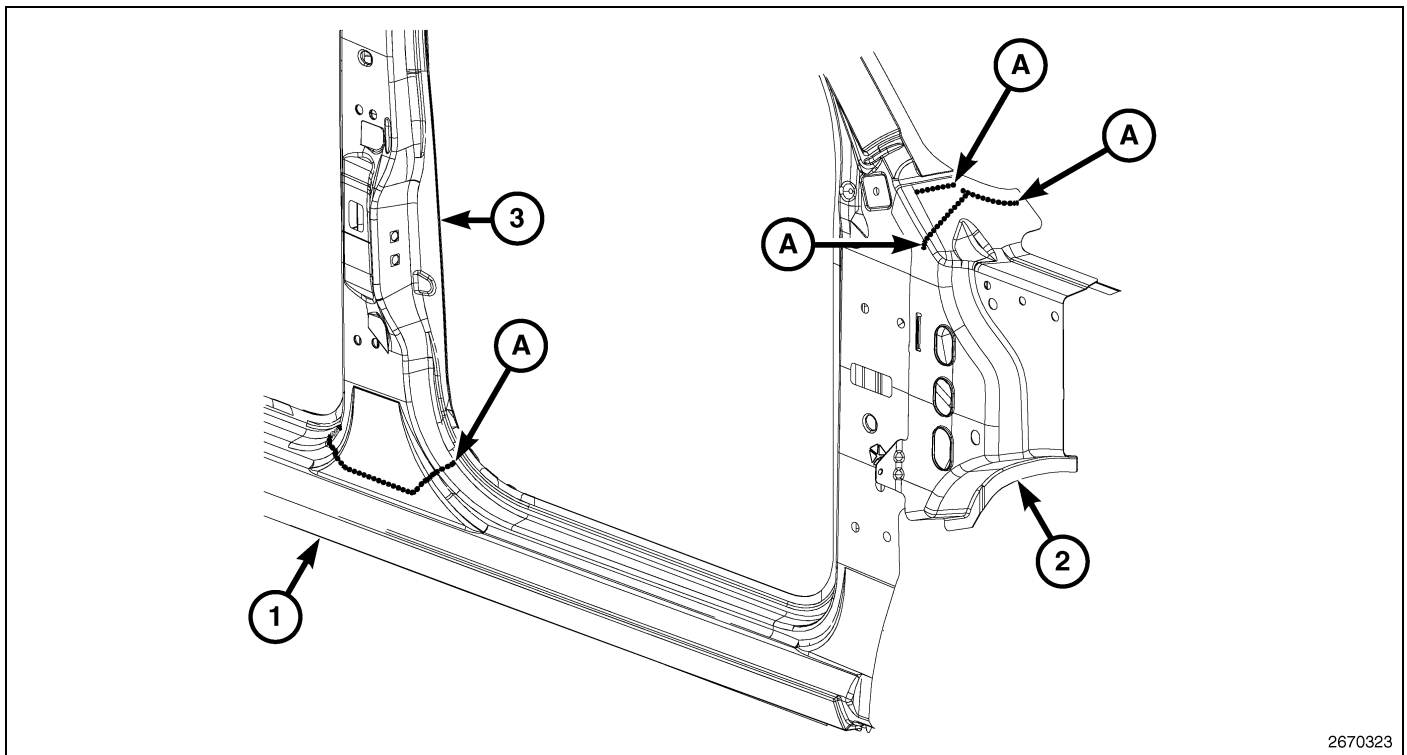

2670323

Fig. 70 Body Side Aperture Outer – Crew Cab (2 of 2)

- A - ORDINARY STRUCTURAL ADHESIVE
- 1 - OUTER BODY SIDE PANEL
- 2 - APERTURE FRONT EXTENSION PLATE
- 3 - B-PILLAR REINFORCEMENT

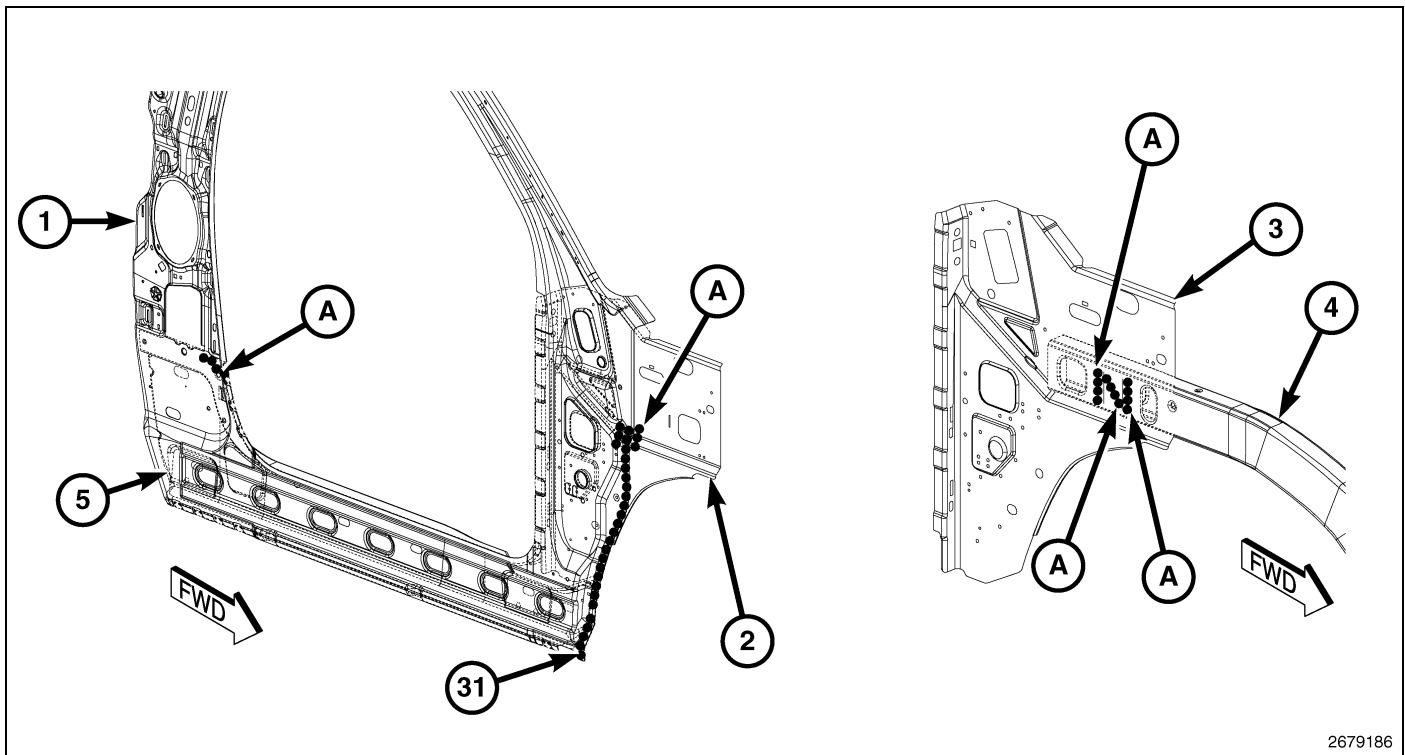

2679186

Fig. 71 Cab Complete – Standard (1 of 2)

- A - ORDINARY STRUCTURAL ADHESIVE
- 1 - INNER BODY SIDE PANEL
- 2 - COWL SIDE PANEL
- 3 - APERTURE FRONT EXTENSION PLATE
- 4 - FENDER/RADIATOR TUBE
- 5 - CAB FLOOR SILL

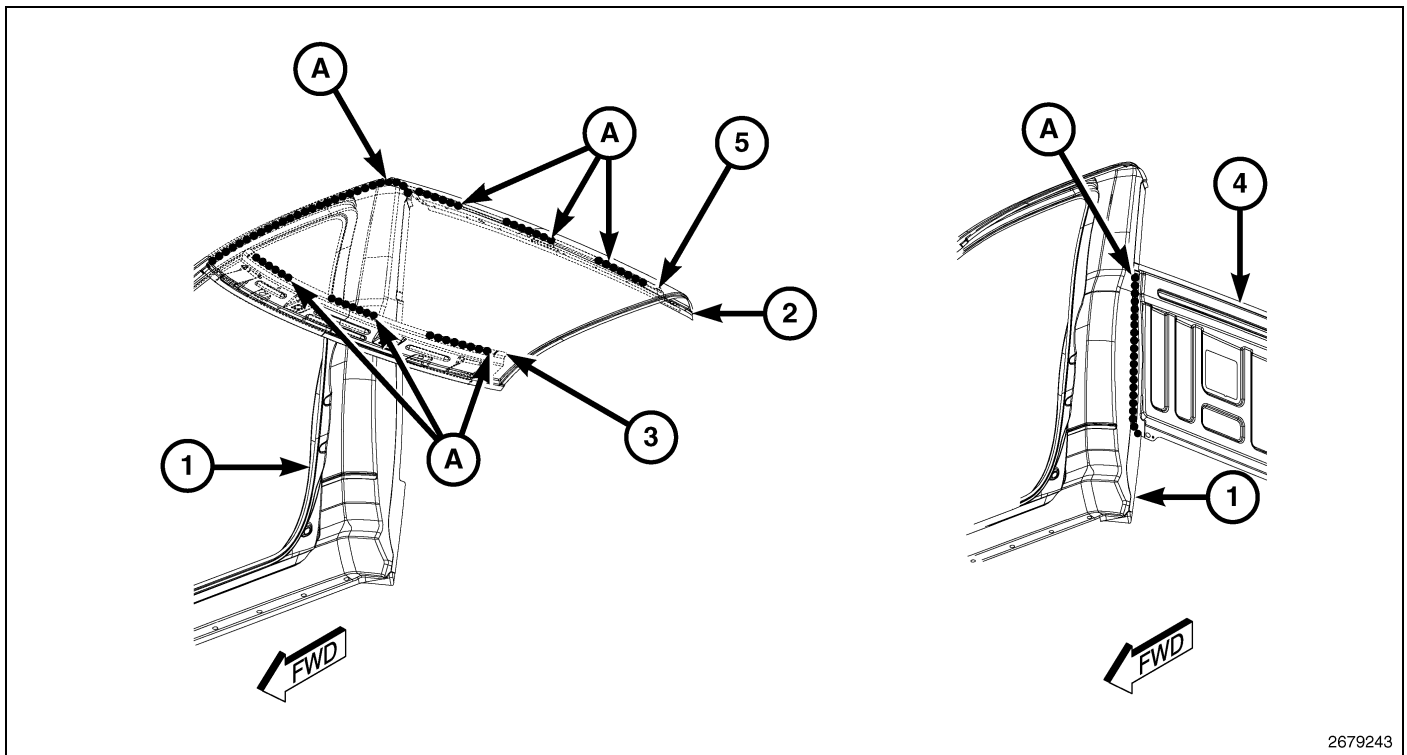

2679243

Fig. 72 Cab Complete – Standard (2 of 2)

- A - ORDINARY STRUCTURAL ADHESIVE
- 1 - OUTER BODY SIDE PANEL
- 2 - ROOF PANEL
- 3 - FRONT ROOF HEADER
- 4 - CAB BACK PANEL
- 5 - REAR ROOF HEADER

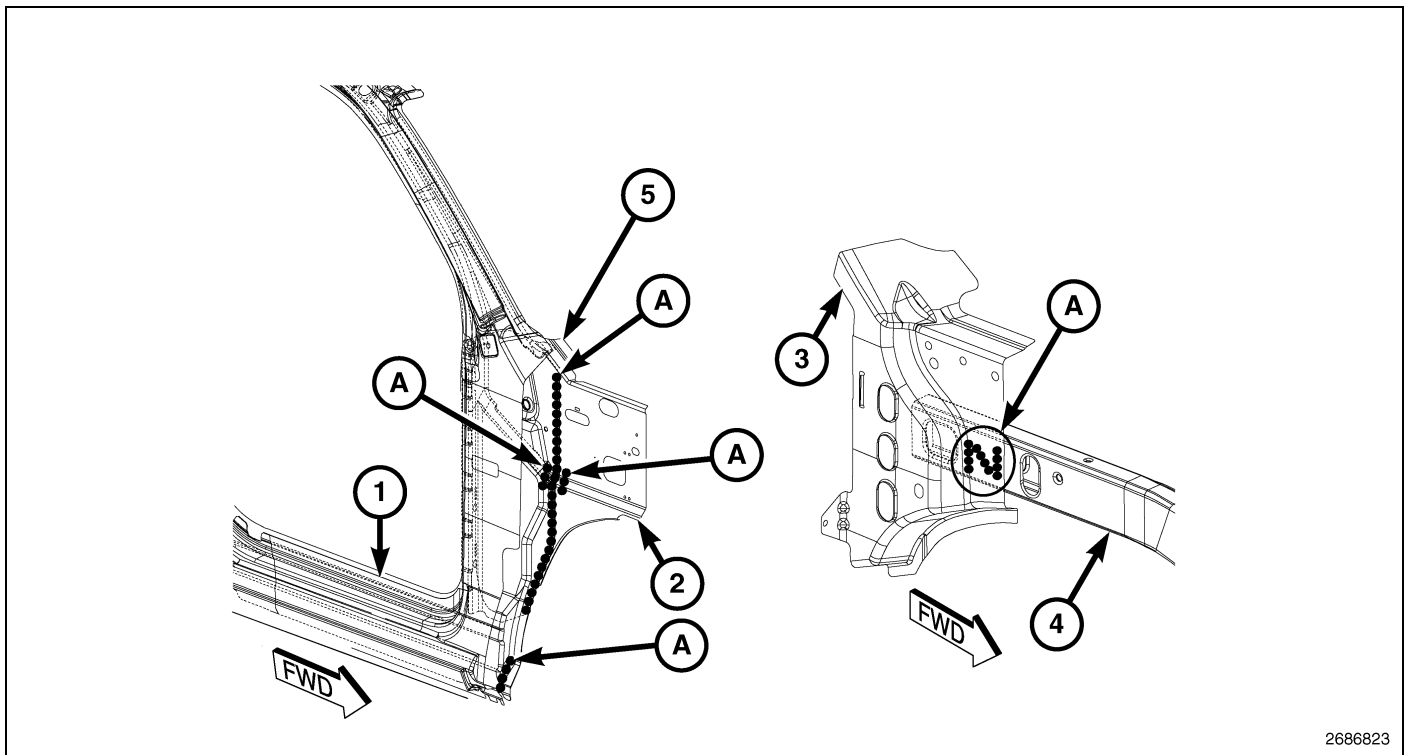

Fig. 73 Cab Complete – Quad (1 of 4)

- A - ORDINARY STRUCTURAL ADHESIVE
- 1 - INNER BODY SIDE PANEL
- 2 - COWL SIDE PANEL
- 3 - APERTURE FRONT EXTENSION PLATE
- 4 - FENDER/RADIATOR TUBE
- 5 - OUTER BODY SIDE PANEL

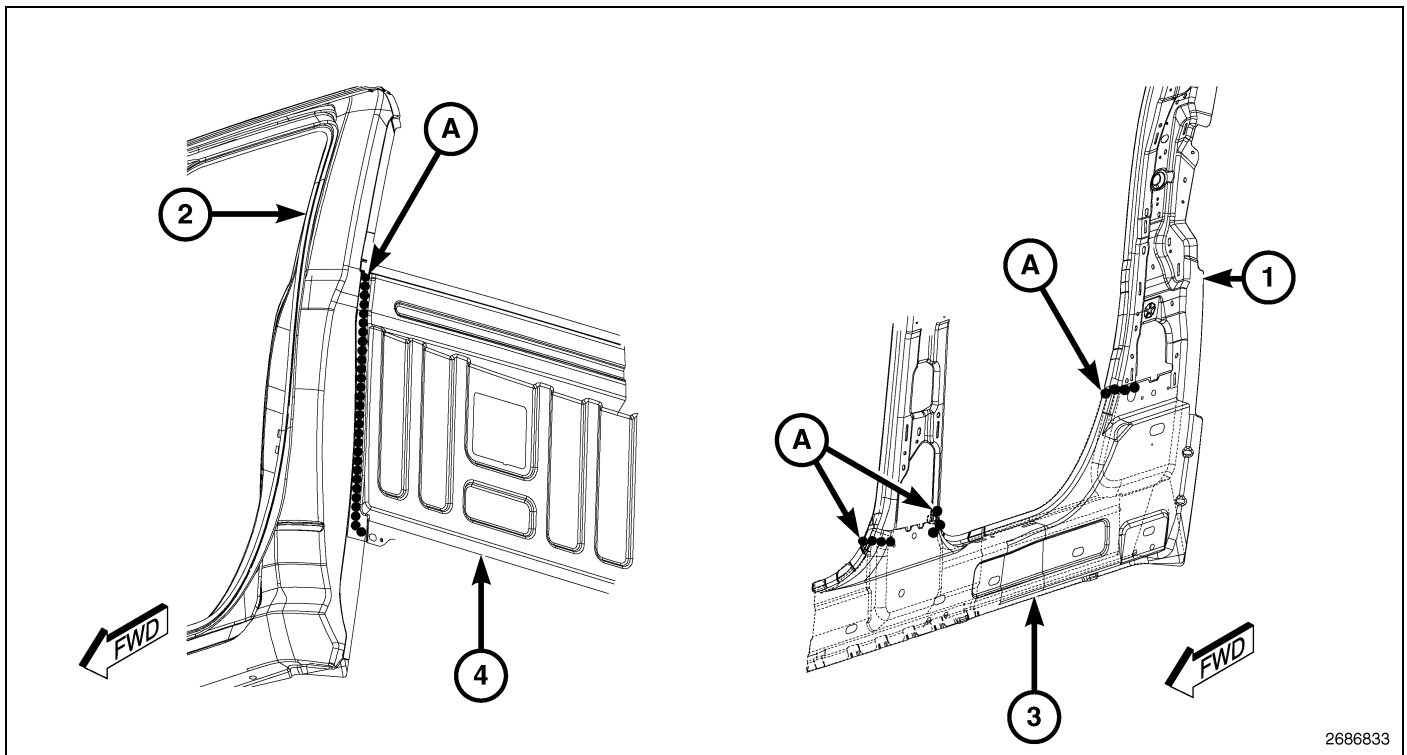

Fig. 74 Cab Complete – Quad (2 of 4)

A - ORDINARY STRUCTURAL ADHESIVE

1 - INNER BODY SIDE PANEL

2 - OUTER BODY SIDE PANEL

3 - CAB FLOOR SILL

4 - CAB BACK PANEL

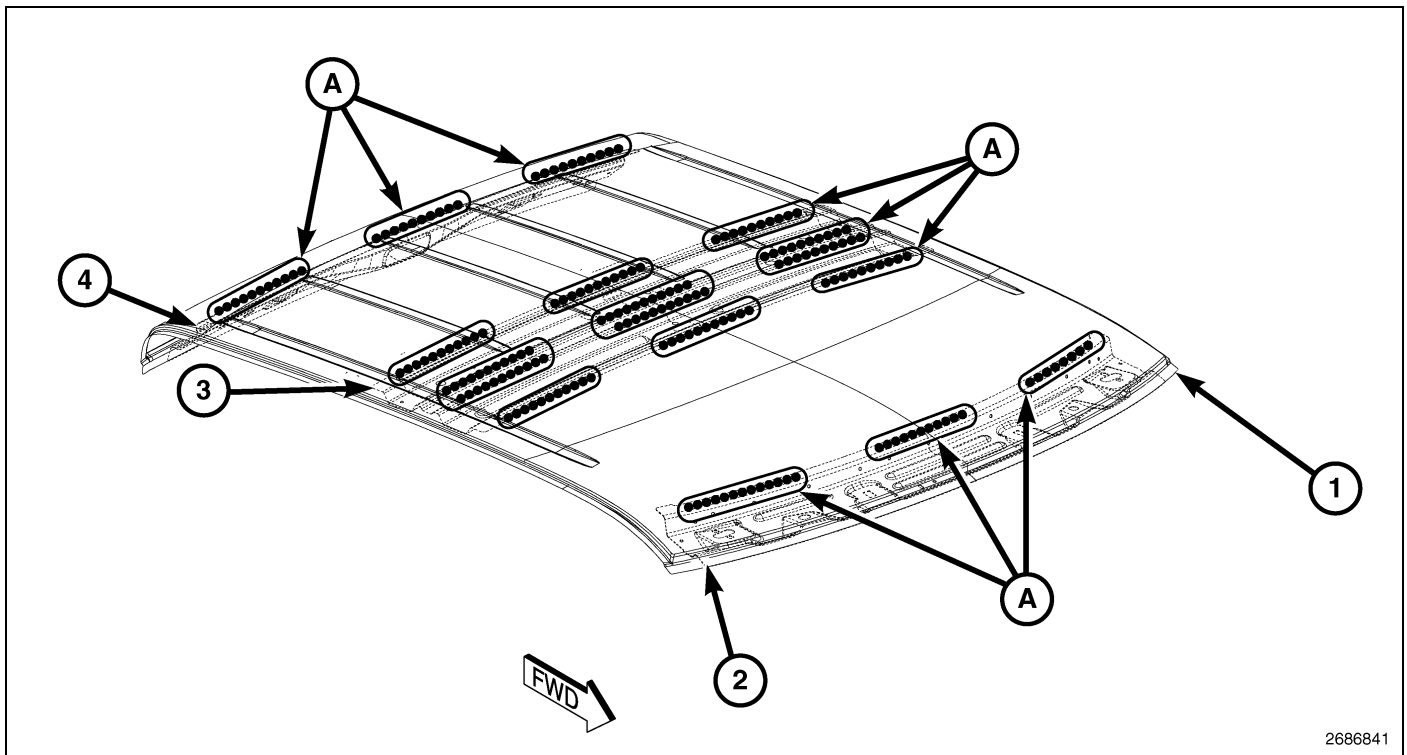

Fig. 75 Cab Complete – Quad (3 of 4)

A - ORDINARY STRUCTURAL ADHESIVE

1 - ROOF PANEL

2 - FRONT ROOF HEADER

3 - B-PILLAR ROOF BOW

4 - REAR ROOF HEADER

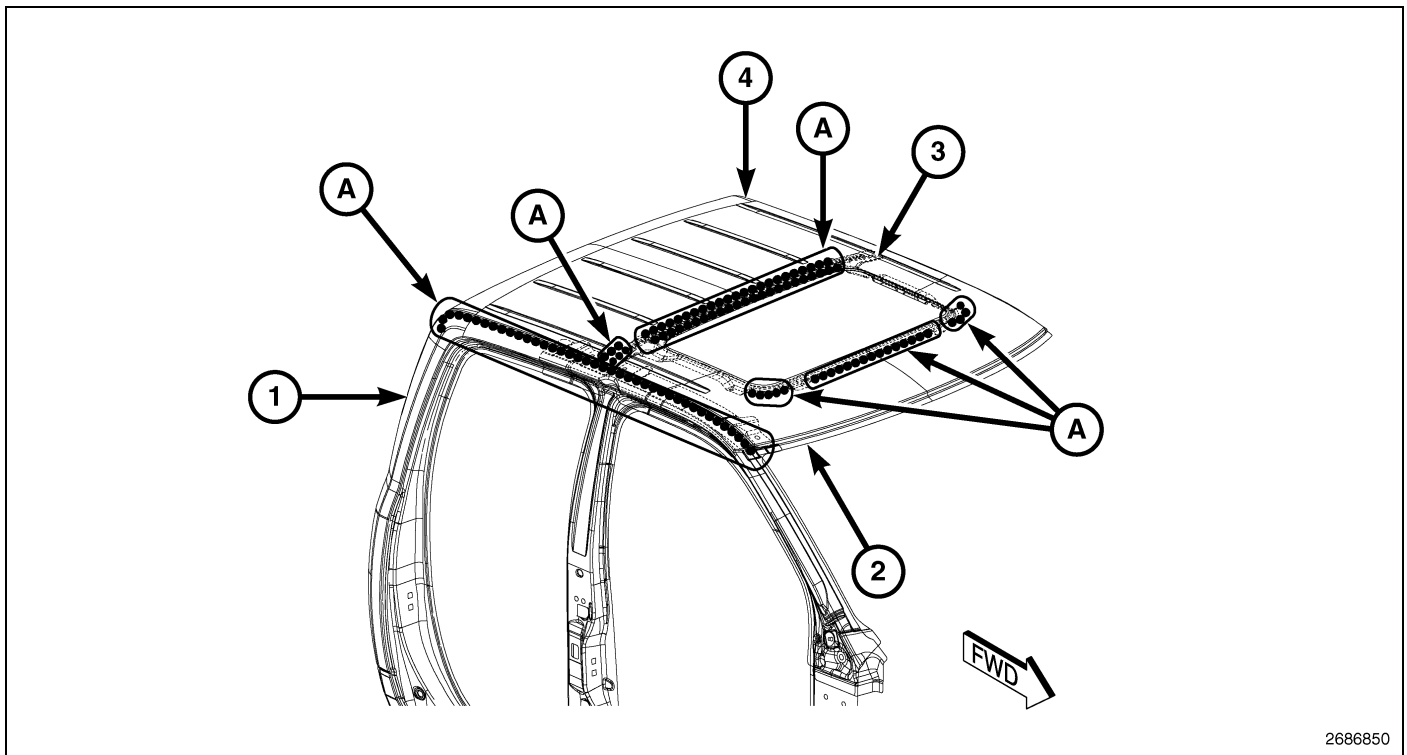
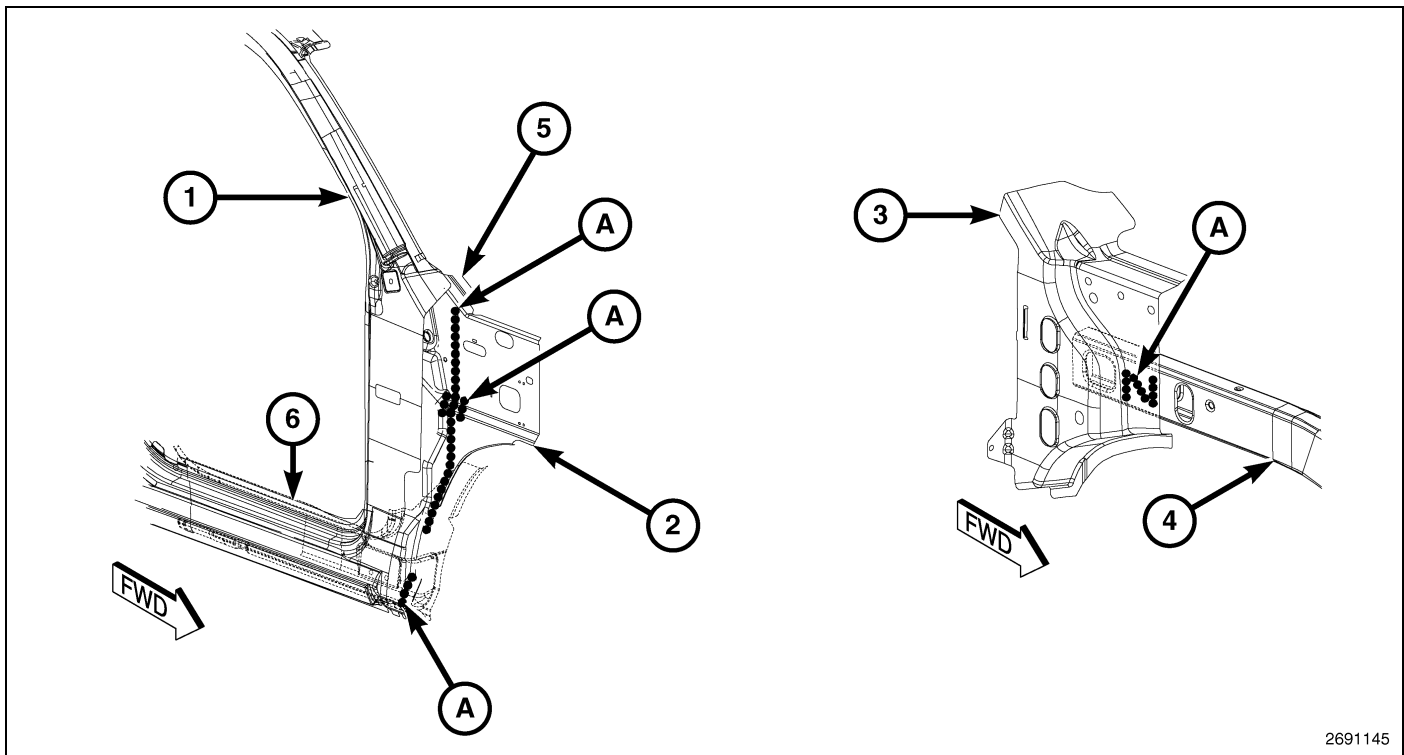

Fig. 76 Cab Complete – Quad (4 of 4)

- A - ORDINARY STRUCTURAL ADHESIVE
- 1 - OUTER BODY SIDE PANEL
- 2 - A-PILLAR REINFORCEMENT
- 3 - SUN ROOF REINFORCEMENT
- 4 - SUN ROOF PANEL



2691145

Fig. 77 Cab Complete – Crew (1 of 5)

A - ORDINARY STRUCTURAL ADHESIVE

1 - INNER BODY SIDE PANEL

2 - COWL SIDE PANEL

3 - APERTURE FRONT EXTENSION PLATE

4 - FENDER/RADIATOR TUBE

5 - OUTER BODY SIDE PANEL

6 - CAB FLOOR SILL

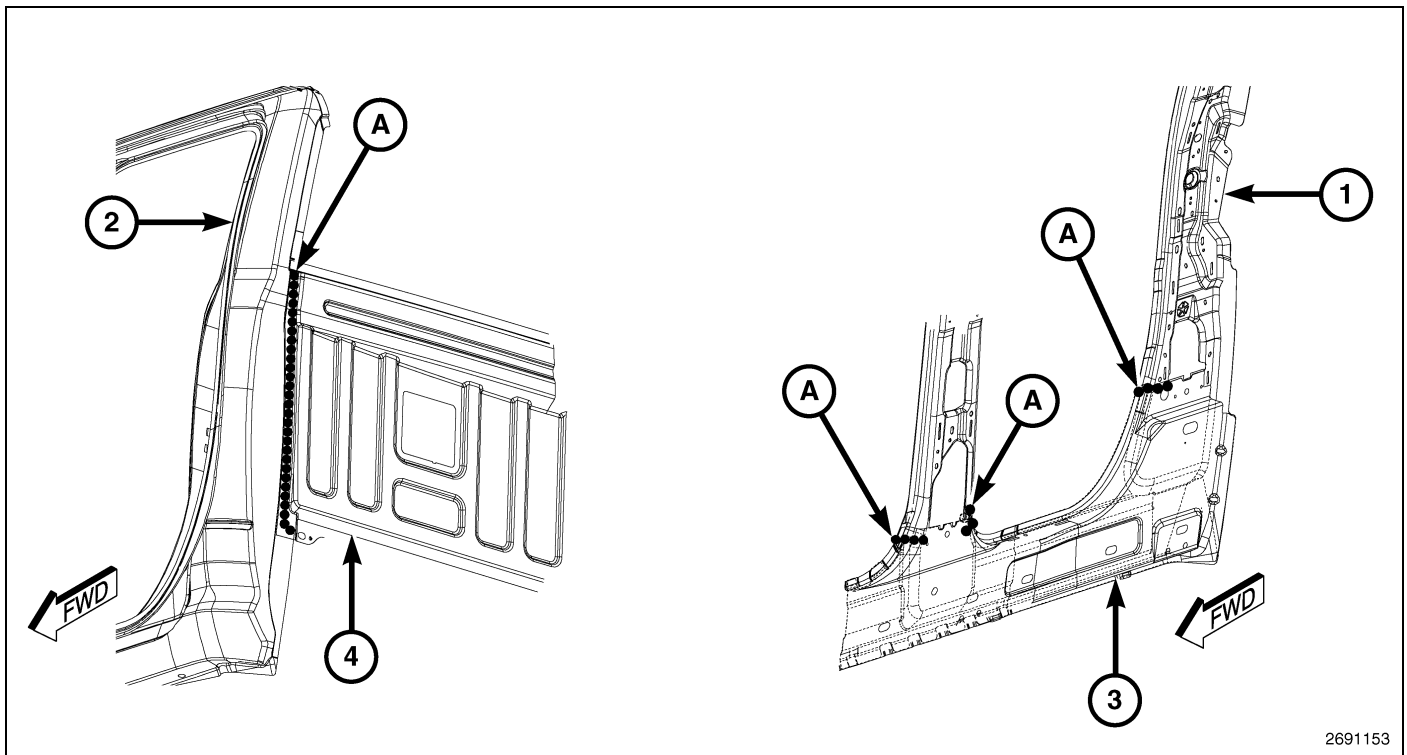
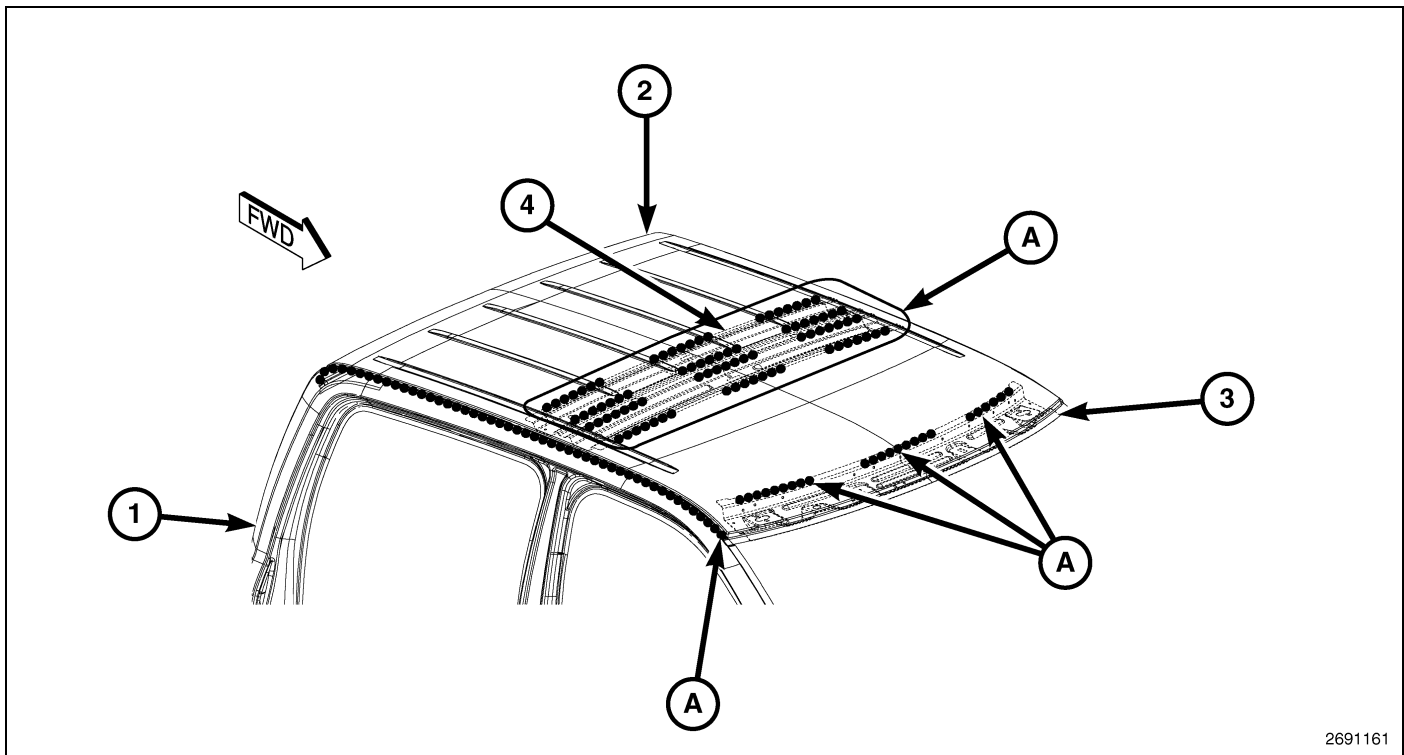

Fig. 78 Cab Complete – Crew (2 of 5)

- A - ORDINARY STRUCTURAL ADHESIVE
- 1 - INNER BODY SIDE PANEL
- 2 - OUTER BODY SIDE PANEL
- 3 - CAB FLOOR SILL
- 4 - CAB BACK PANEL



2691161

Fig. 79 Cab Complete – Crew (3 of 5)

A - ORDINARY STRUCTURAL ADHESIVE

1 - OUTER BODY SIDE PANEL

2 - ROOF PANEL

3 - FRONT ROOF HEADER

4 - B-PILLAR ROOF BOW

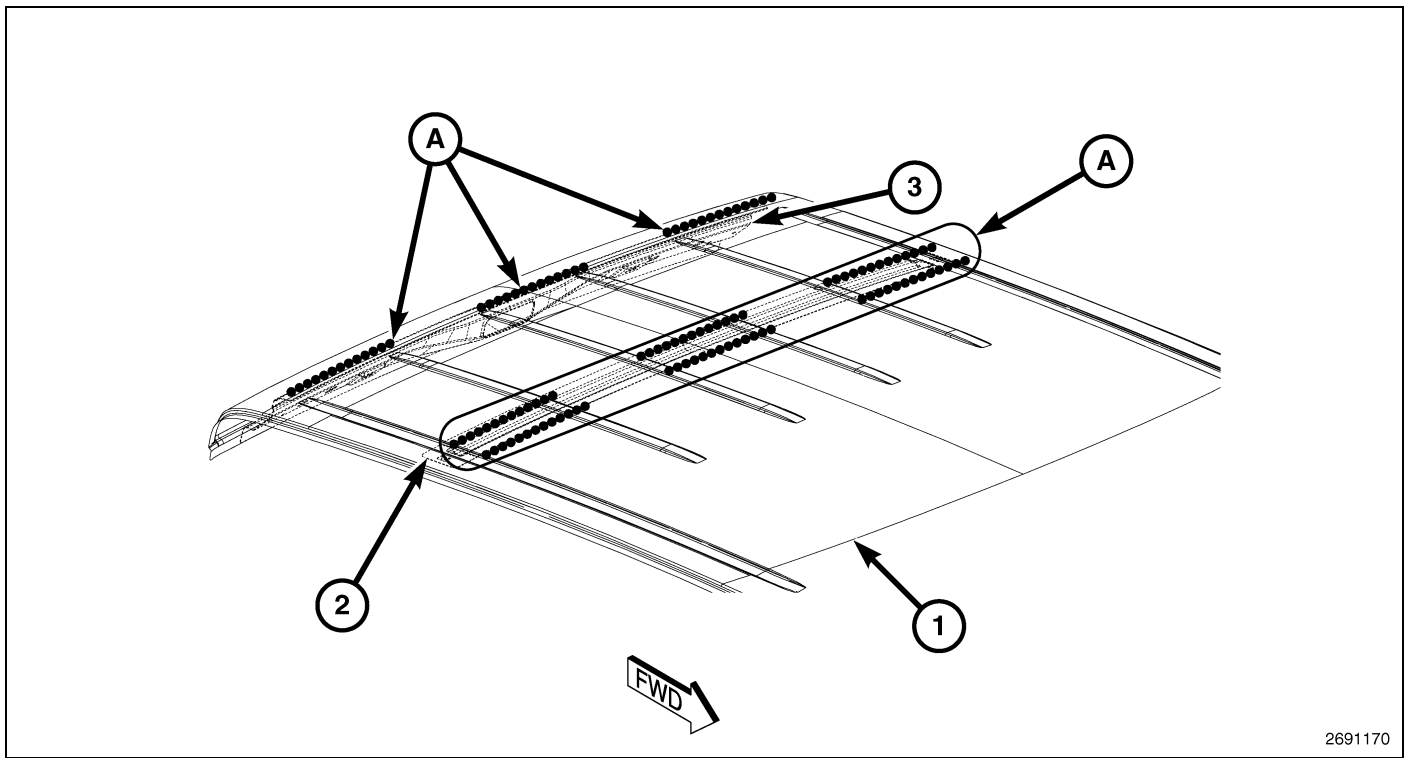

Fig. 80 Cab Complete – Crew (4 of 5)

A - ORDINARY STRUCTURAL ADHESIVE

1 - ROOF PANEL

2 - 2ND ROOF BOW

3 - REAR ROOF HEADER

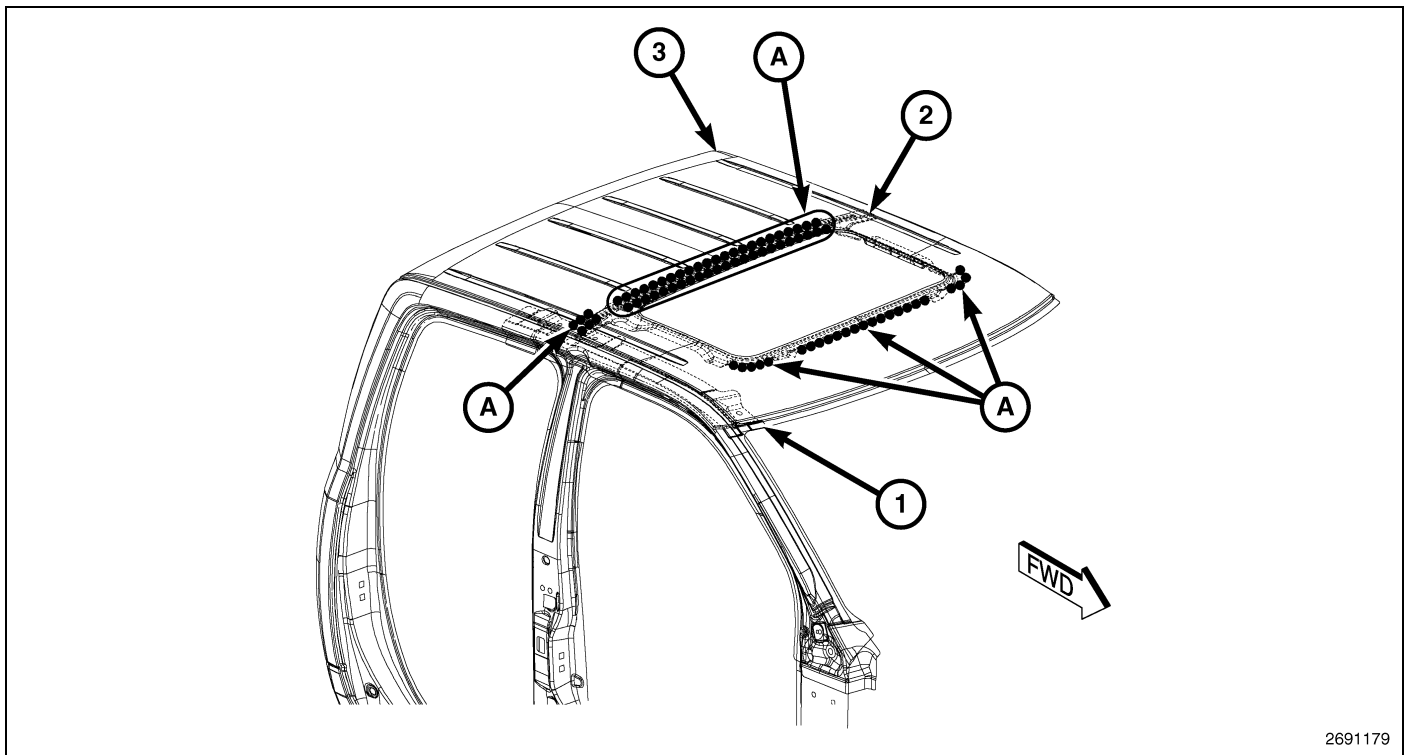

Fig. 81 Cab Complete – Crew (5 of 5)

A - ORDINARY STRUCTURAL ADHESIVE

1 - A-PILLAR REINFORCEMENT

2 - SUNROOF REINFORCEMENT

3 - SUNROOF ROOF PANEL

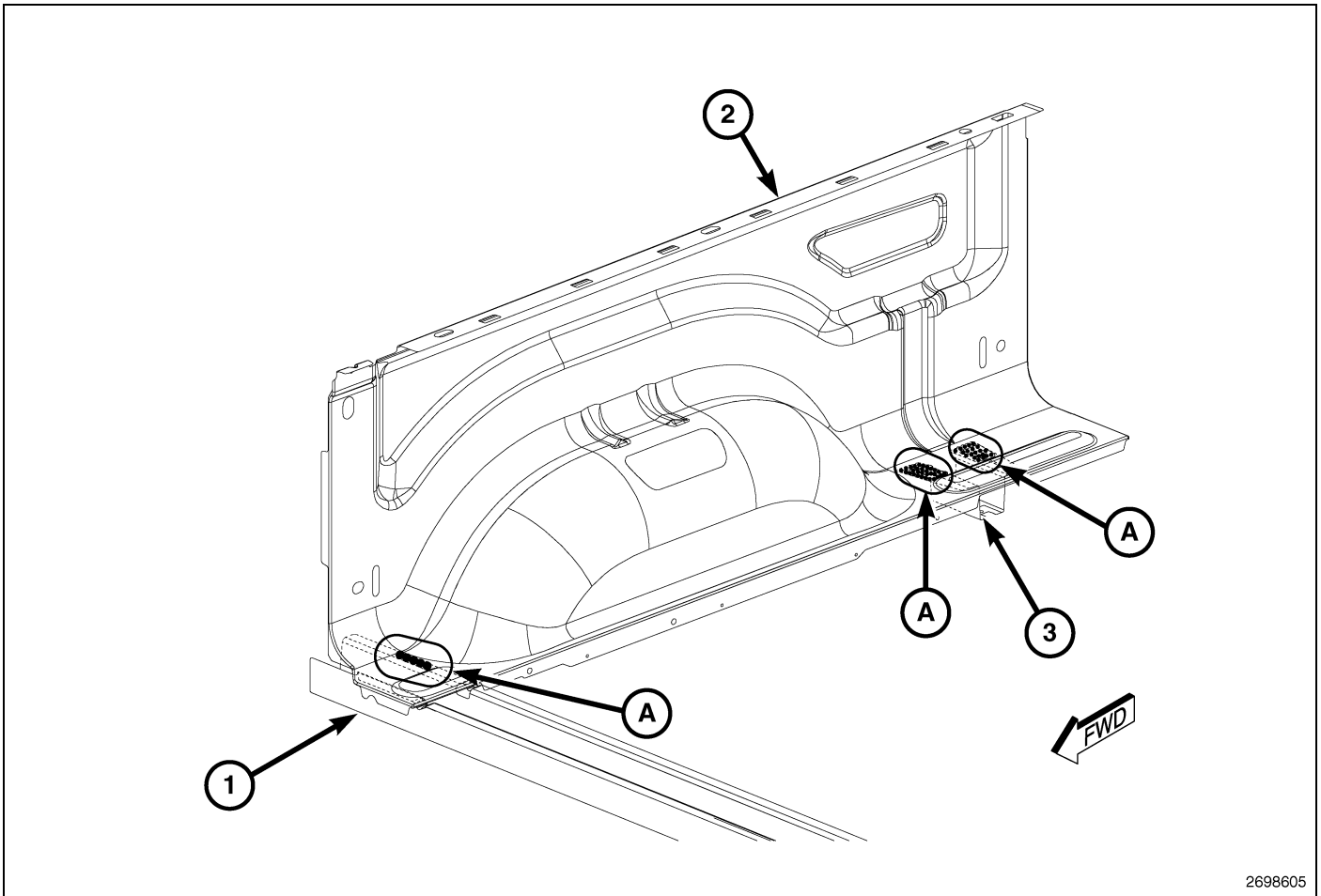

2698605

Fig. 82 5.7' Ram Box Floor

A - ORDINARY STRUCTURAL ADHESIVE

1 - FRONT CROSSMEMBER

2 - INNER BOX SIDE PANEL

3 - CROSSMEMBER END BRACKET

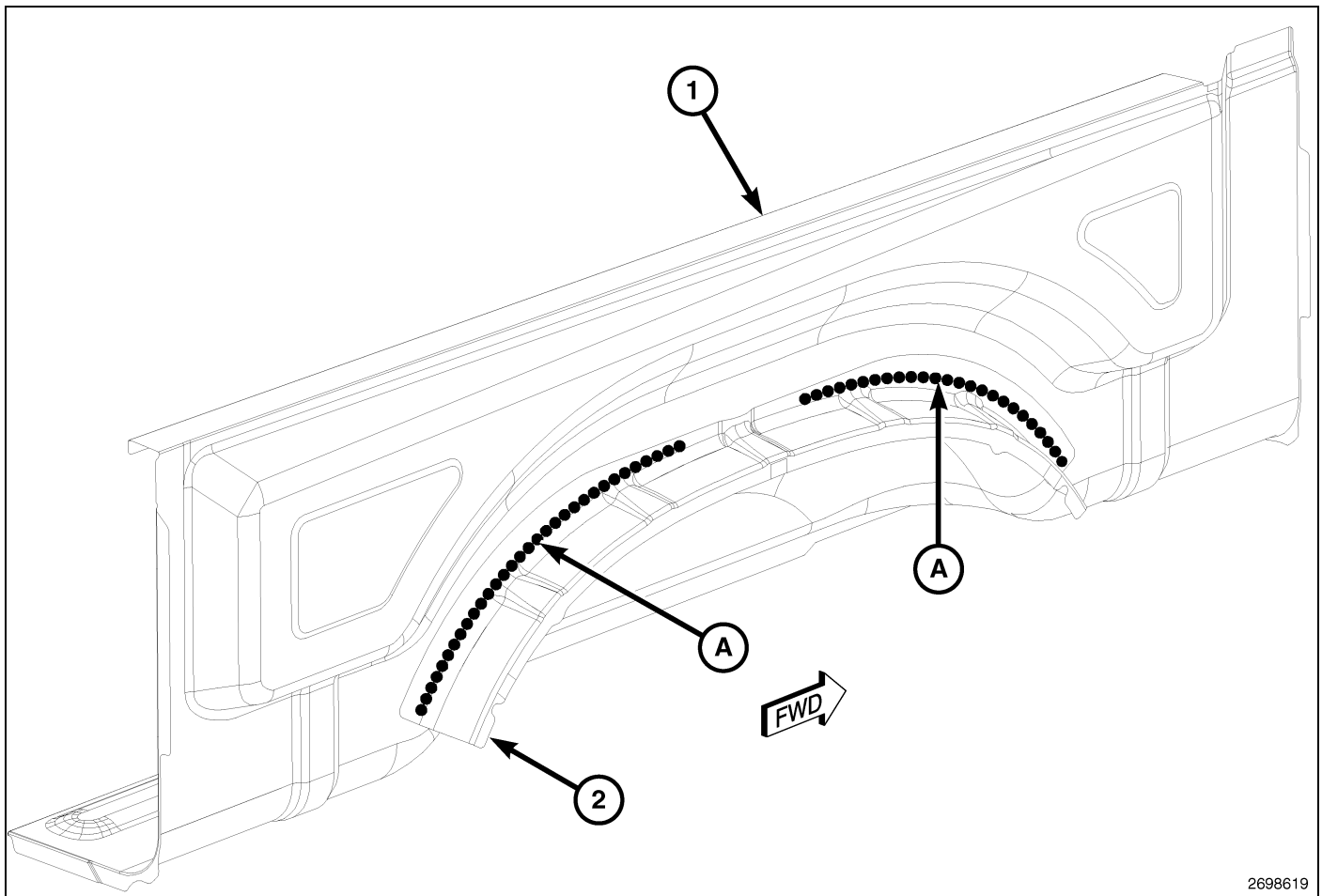
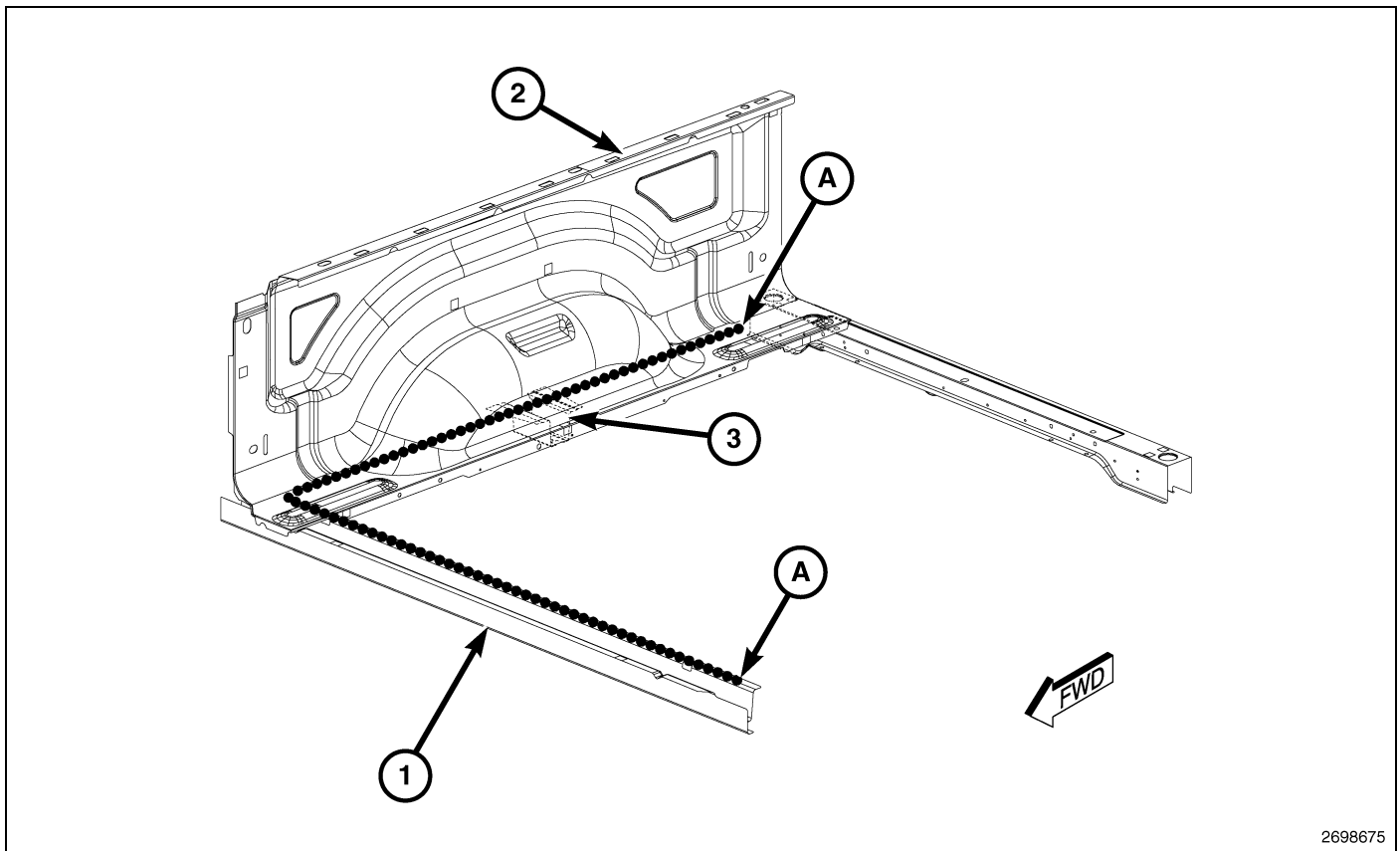

Fig. 83 6.3' Box Tub

A - ORDINARY STRUCTURAL ADHESIVE

1 - INNER BOX SIDE PANEL

2 - INNER WHEELHOUSE



2698675

Fig. 84 6.3' Box Floor

- A - ORDINARY STRUCTURAL ADHESIVE
- 1 - FRONT CROSSMEMBER
- 2 - INNER BOX SIDE PANEL
- 3 - PAINT CARRIER BRACKET

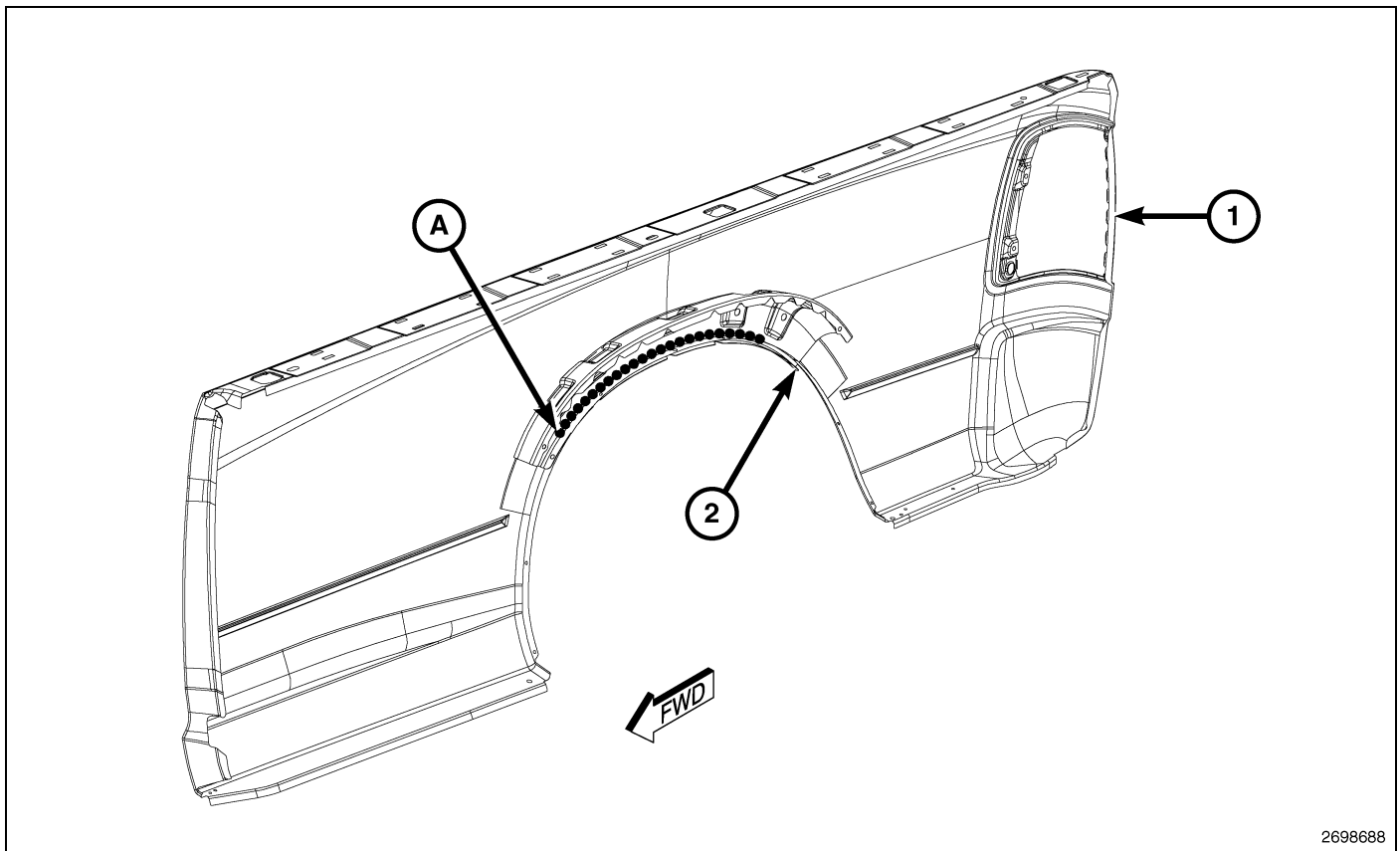
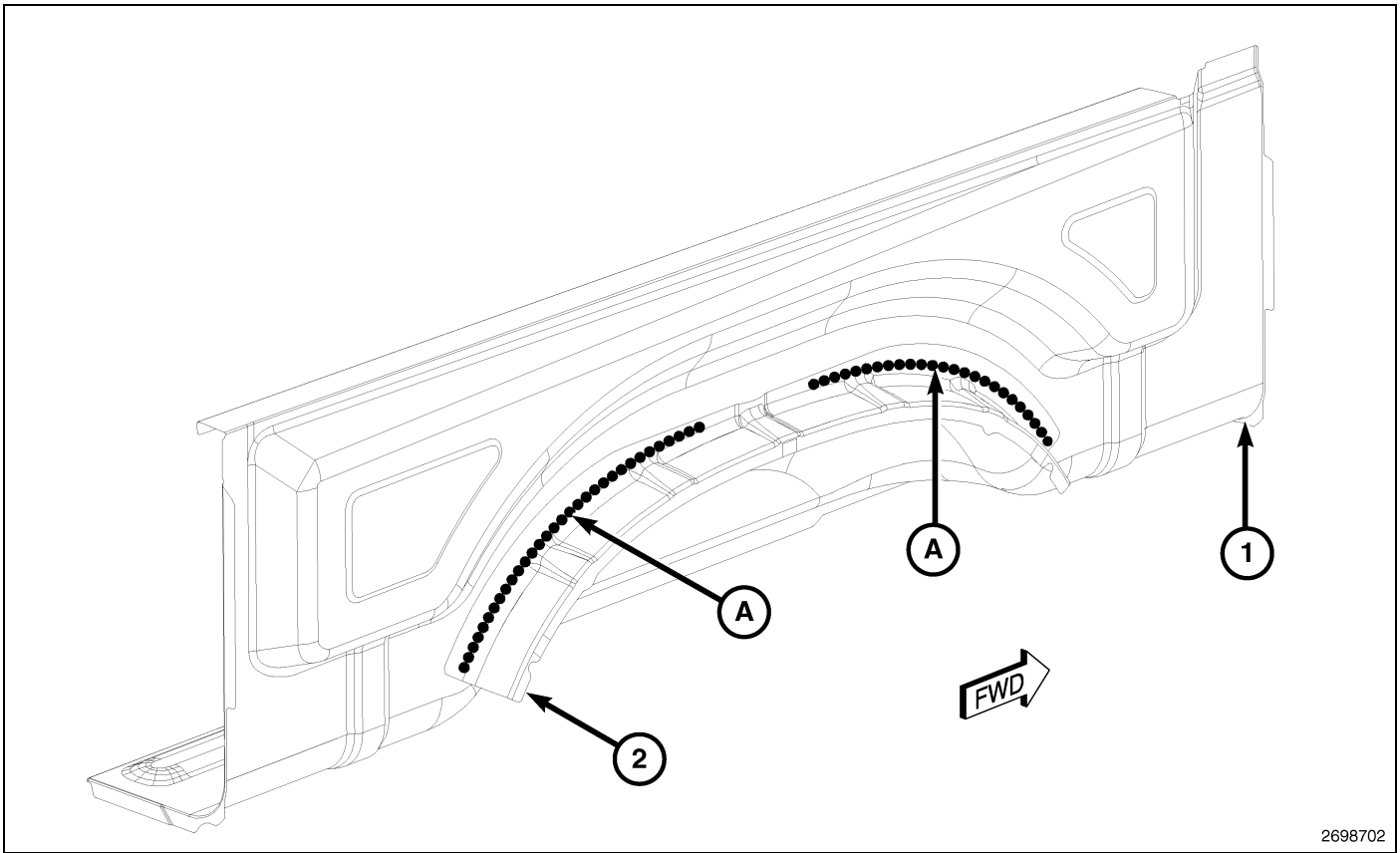

Fig. 85 8.0' Box Body in White

A - ORDINARY STRUCTURAL ADHESIVE

1 - OUTER BOX SIDE PANEL

2 - OUTER WHEELHOUSE



2698702

Fig. 86 8.0' Box Tub

- A - ORDINARY STRUCTURAL ADHESIVE
- 1 - INNER BOX SIDE PANEL
- 2 - INNER WHEELHOUSE

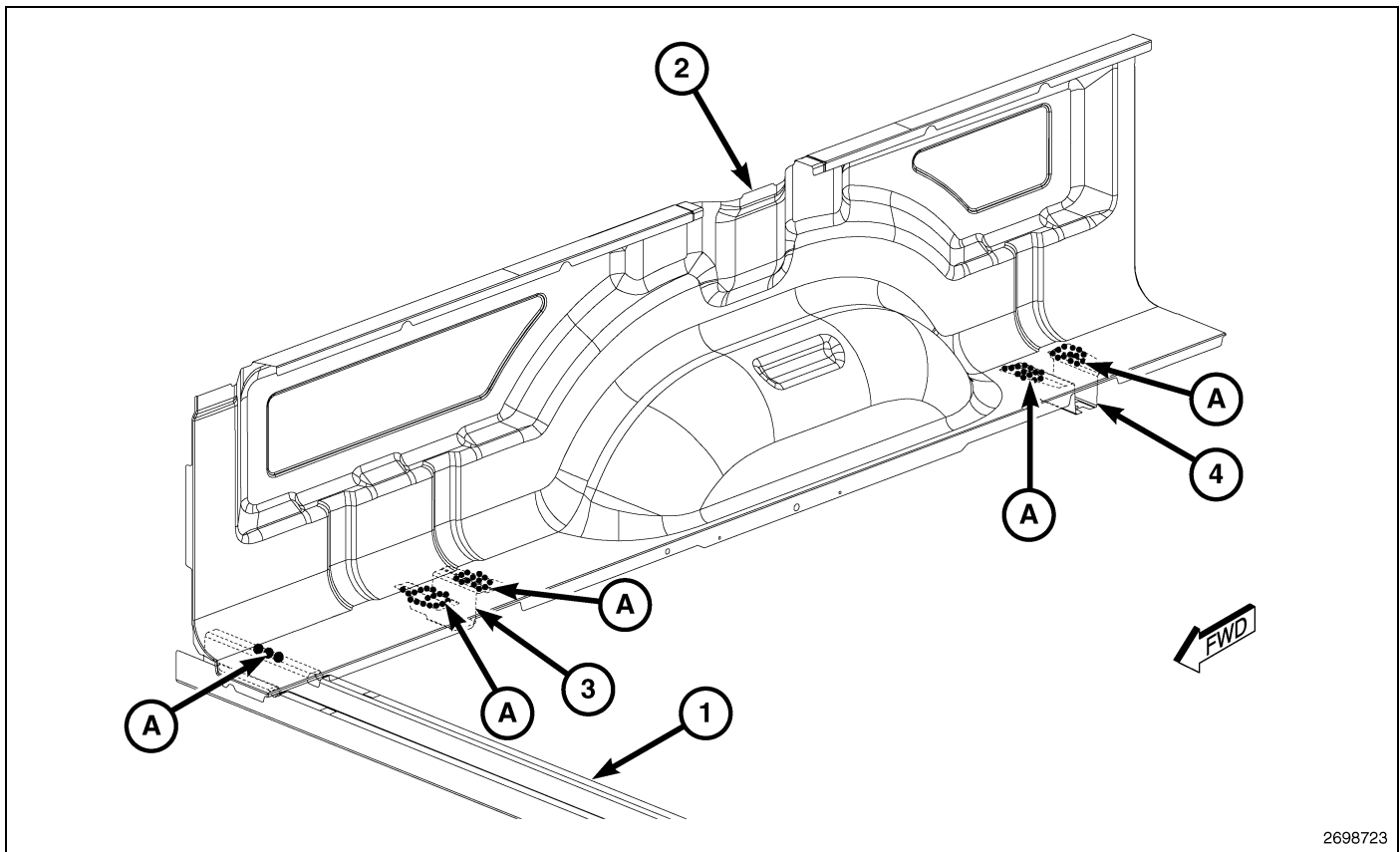

2698723

Fig. 87 8.0' Box Floor

- A - ORDINARY STRUCTURAL ADHESIVE
- 1 - FRONT CROSSMEMBER
- 2 - INNER BOX SIDE PANEL
- 3 - CROSSMEMBER END SUPPORT BRACKET
- 4 - CROSSMEMBER END BRACKET

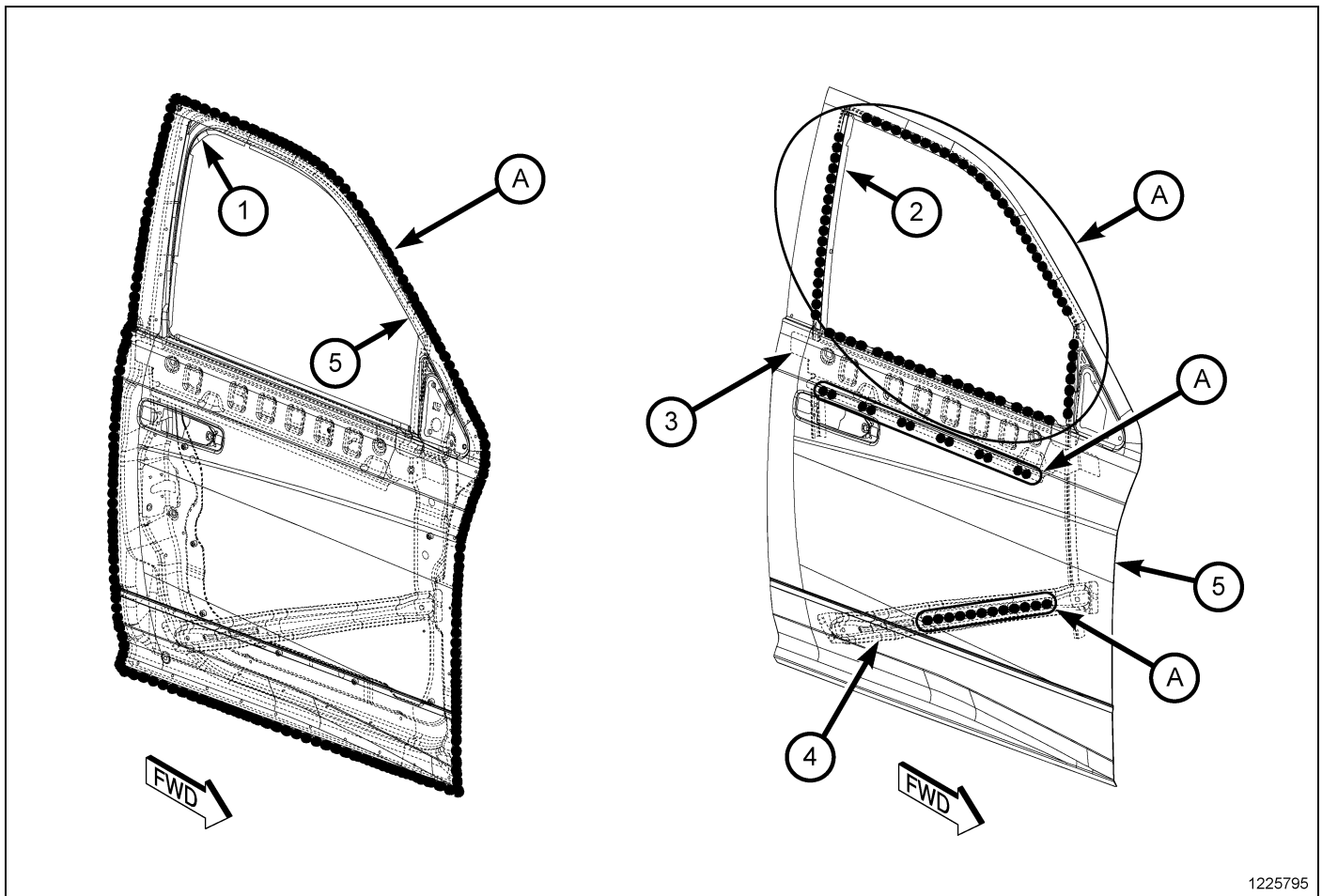

1225795

Fig. 88 Front Doors - Short

- A - ORDINARY STRUCTURAL ADHESIVE
- 1 - INNER DOOR PANEL
- 2 - GLASS RUN CHANNEL
- 3 - DOOR BELT OUTER REINFORCEMENT
- 4 - IMPACT BEAM
- 5 - OUTER DOOR PANEL

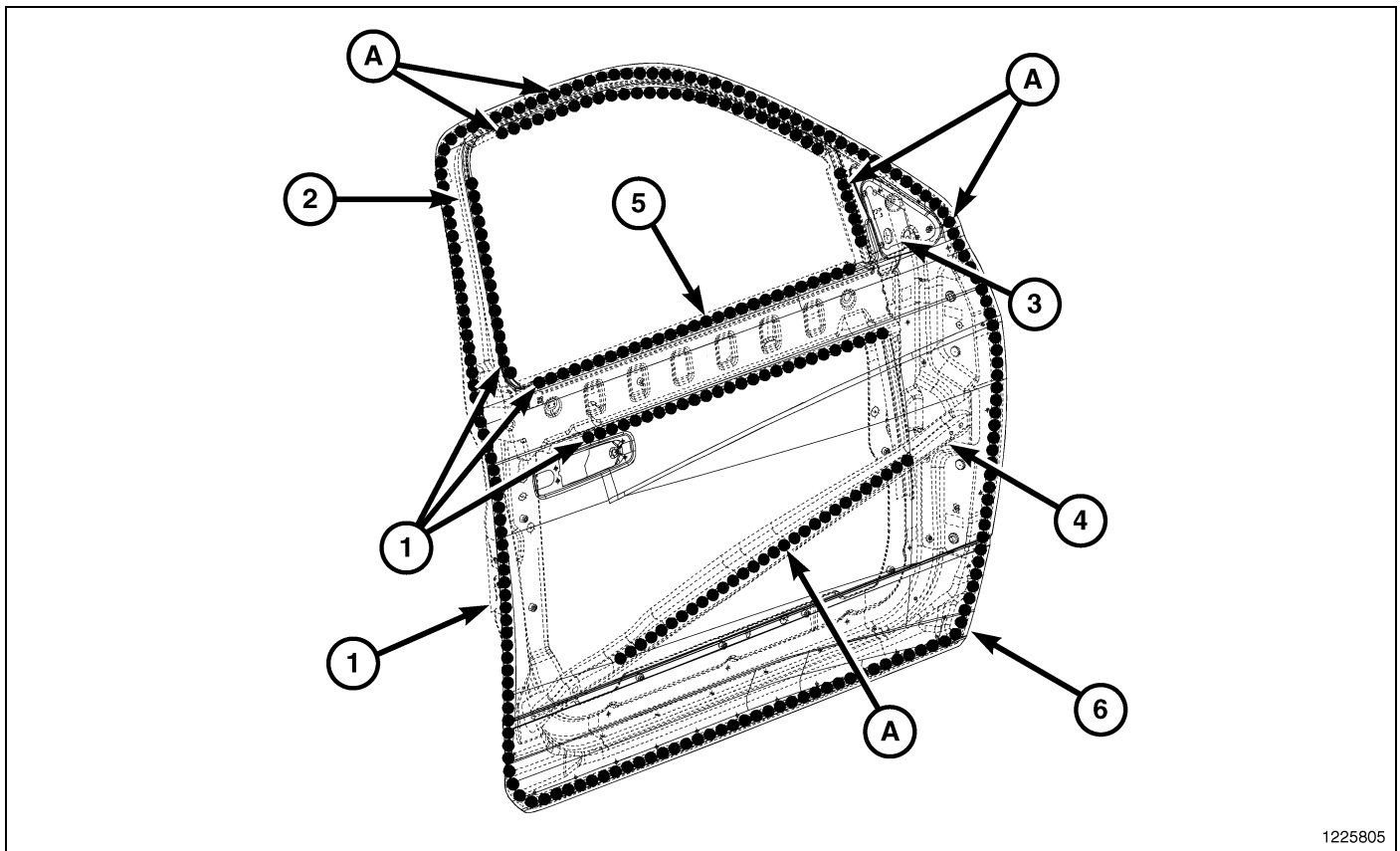
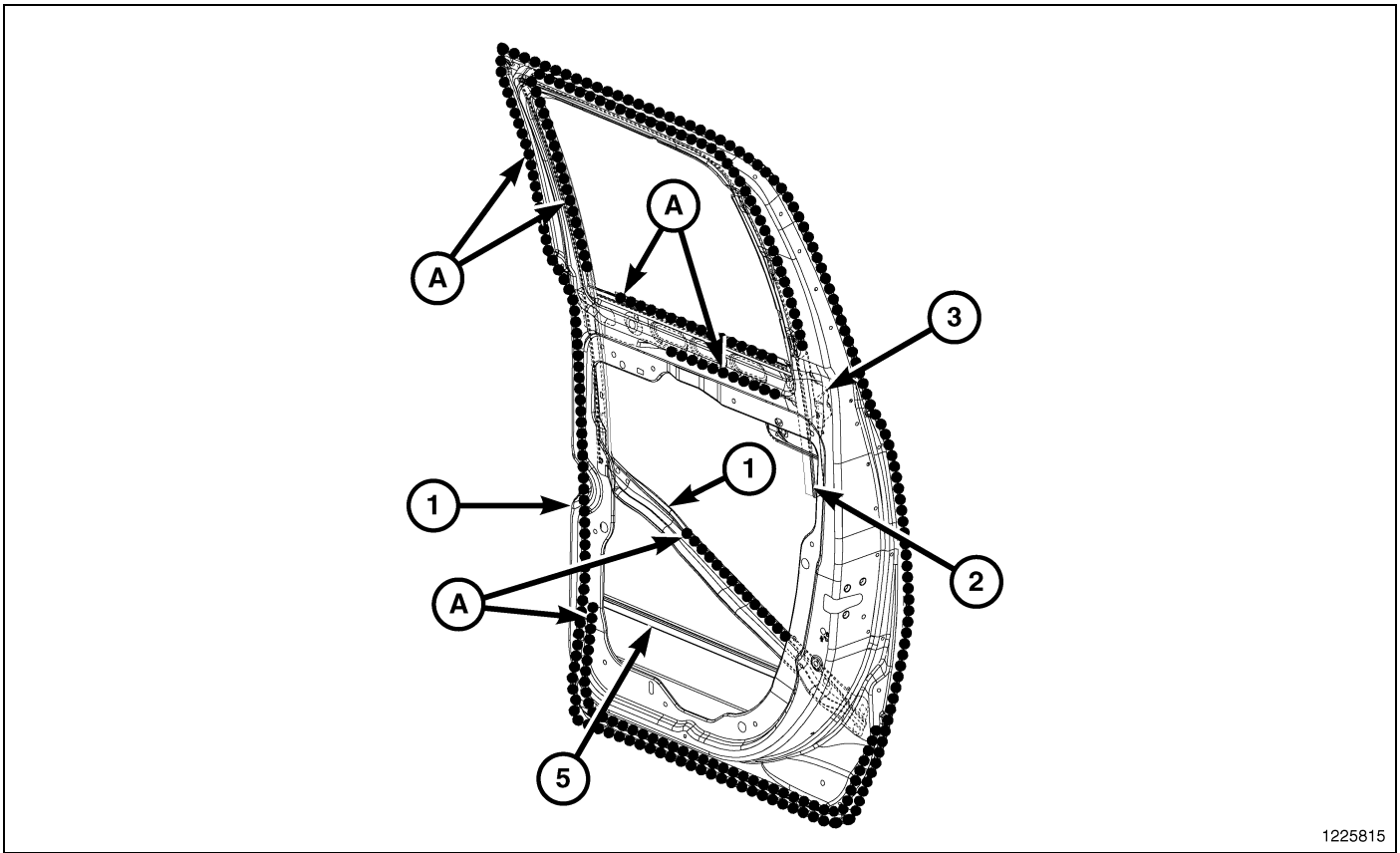

Fig. 89 Front Doors - Long

- A - ORDINARY STRUCTURAL ADHESIVE
- 1 - INNER DOOR PANEL
- 2 - GLASS RUN CHANNEL
- 3 - MIRROR MOUNT REINFORCEMENT
- 4 - DOOR IMPACT BEAM
- 5 - DOOR BELT OUTER REINFORCEMENT
- 6 - OUTER DOOR PANEL



1225815

Fig. 90 Rear Doors - Half

- A - ORDINARY STRUCTURAL ADHESIVE
- 1 - INNER DOOR PANEL
- 2 - GLASS RUN CHANNEL
- 3 - DOOR BELT OUTER REINFORCEMENT
- 4 - IMPACT BEAM
- 5 - OUTER DOOR PANEL

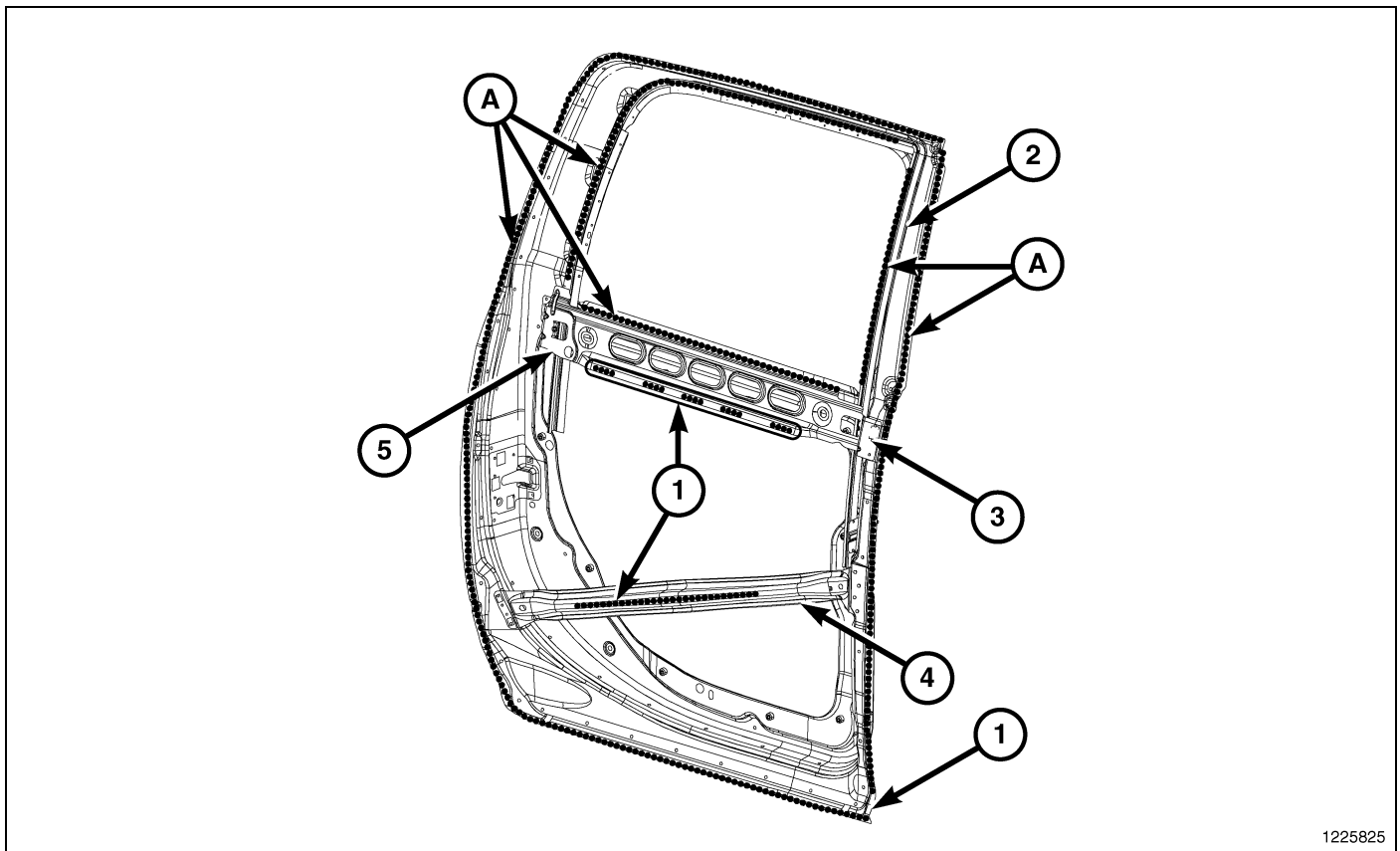

1225825

Fig. 91 Rear Doors - Full

- A - ORDINARY STRUCTURAL ADHESIVE
- 1 - INNER DOOR PANEL
- 2 - GLASS RUN CHANNEL
- 3 - DOOR BELT OUTER REINFORCEMENT
- 4 - IMPACT BEAM
- 5 - OUTER DOOR PANEL

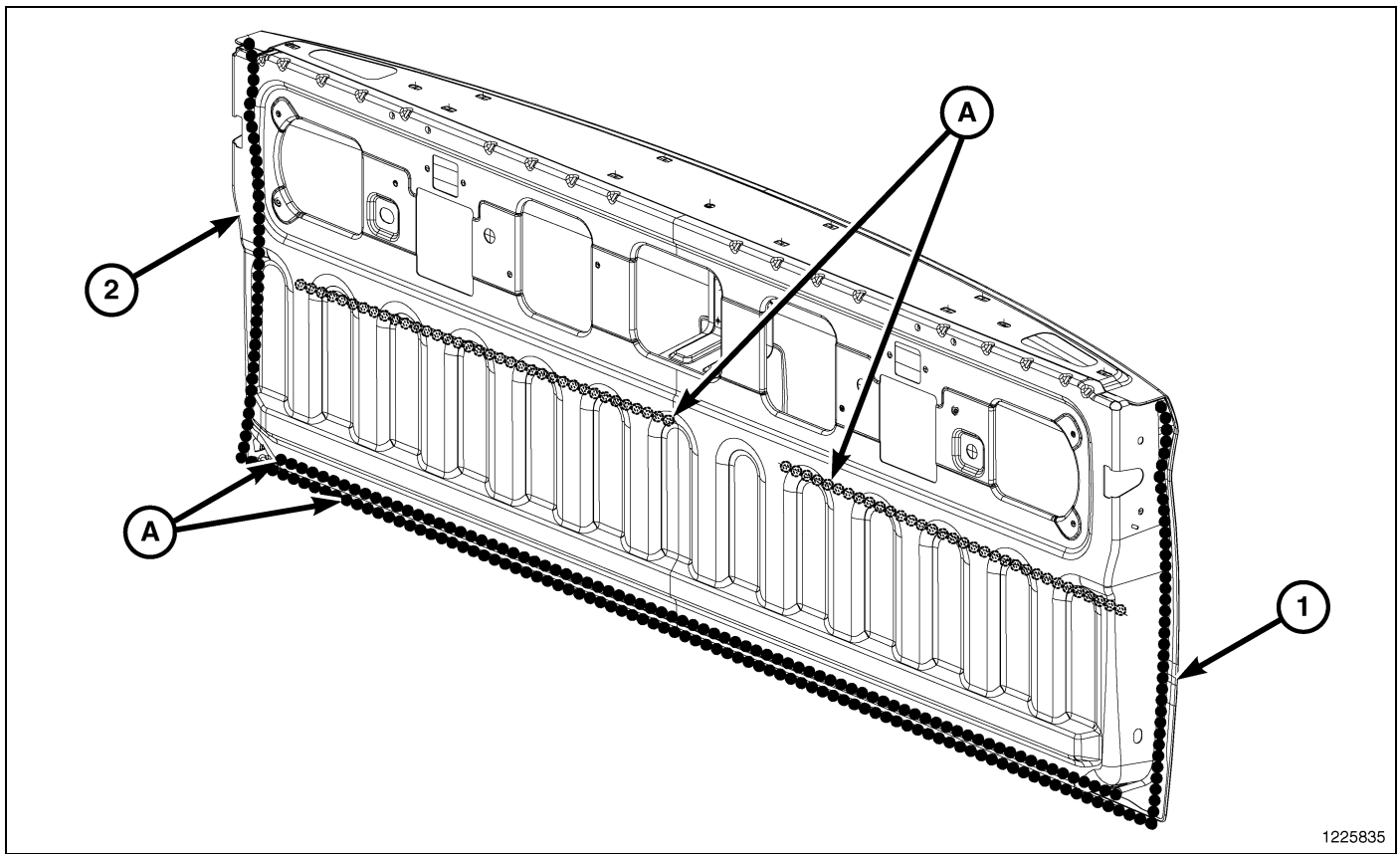

1225835

Fig. 92 Tailgate

A - ORDINARY STRUCTURAL ADHESIVE

1 - OUTER TAILGATE PANEL

2 - INNER TAILGATE PANEL